



Quick Start Guide

Replication Server® Options

15.5

[Linux, Microsoft Windows, and UNIX]

DOCUMENT ID: DC00766-01-1550-01

LAST REVISED: May 2010

Copyright © 2010 by Sybase, Inc. All rights reserved.

This publication pertains to Sybase software and to any subsequent release until otherwise indicated in new editions or technical notes. Information in this document is subject to change without notice. The software described herein is furnished under a license agreement, and it may be used or copied only in accordance with the terms of that agreement.

To order additional documents, U.S. and Canadian customers should call Customer Fulfillment at (800) 685-8225, fax (617) 229-9845.

Customers in other countries with a U.S. license agreement may contact Customer Fulfillment via the above fax number. All other international customers should contact their Sybase subsidiary or local distributor. Upgrades are provided only at regularly scheduled software release dates. No part of this publication may be reproduced, transmitted, or translated in any form or by any means, electronic, mechanical, manual, optical, or otherwise, without the prior written permission of Sybase, Inc.

Sybase trademarks can be viewed at the [Sybase trademarks page](http://www.sybase.com/detail?id=1011207) at <http://www.sybase.com/detail?id=1011207>. Sybase and the marks listed are trademarks of Sybase, Inc. ® indicates registration in the United States of America.

Java and all Java-based marks are trademarks or registered trademarks of Sun Microsystems, Inc. in the U.S. and other countries.

Unicode and the Unicode Logo are registered trademarks of Unicode, Inc.

All other company and product names mentioned may be trademarks of the respective companies with which they are associated.

Use, duplication, or disclosure by the government is subject to the restrictions set forth in subparagraph (c)(1)(ii) of DFARS 52.227-7013 for the DOD and as set forth in FAR 52.227-19(a)-(d) for civilian agencies.

Sybase, Inc., One Sybase Drive, Dublin, CA 94568.

Contents

About This Book	v
CHAPTER 1 Setting Up Replication for Oracle	1
Sybase replication system	1
Prerequisites	2
System requirements	3
Installing replication components	3
Before you start	4
Installing ExpressConnect for Oracle	5
Installing Replication Server	6
Installing Replication Agent	10
Configuring replication components	13
Configuring ExpressConnect for Oracle	13
Configuring Replication Server	13
Configuring Replication Agent	18
Testing replication	31
Resetting the primary Oracle database for replication	32
CHAPTER 2 Setting Up Replication for Microsoft SQL Server	35
Sybase replication system	35
Prerequisites	36
System requirements	37
Installing replication components	37
Identifying the Sybase installation directory	38
Accessing products from the SPDC	38
Installing Replication Agent	40
Installing Replication Server	42
Installing ECDA Option for ODBC	46
Configuring replication components	48
Configuring ECDA Option for ODBC	48
Configuring Replication Server	52
Configuring Replication Agent	55
Testing replication	69

	Resetting the primary Microsoft SQL Server database for replication	70
CHAPTER 3	Setting Up Replication for IBM DB2 Universal Database.....	73
	Sybase replication system	73
	Prerequisites	74
	System requirements	75
	Installing replication components	75
	Identifying the Sybase installation directory	76
	Accessing products from the SPDC	76
	Installing Replication Agent	78
	Installing Replication Server	81
	Installing ECDA Option for ODBC	84
	Configuring replication components	87
	Setting IBM DB2 Universal Database environment variables .	87
	Cataloging a node and a database in an IBM DB2 Universal Database client.....	89
	Configuring ECDA Option for ODBC.....	92
	Configuring Replication Server.....	97
	Configuring Replication Agent.....	102
	Testing replication	113
	Resetting the primary IBM DB2 Universal Database for replication	114
	Glossary	115
	Index	123

About This Book

Replication Server® Options version 15.5 extends the capabilities of Replication Server to support replication to and from the following primary data servers in a Sybase® replication system:

- Oracle Database Server
- Microsoft SQL Server
- IBM DB2 Universal Database (for UNIX and Microsoft Windows)

The Replication Server Options consist of the following components:

- Replication Agent™
- Enterprise Connect™ Data Access (ECDA)
- ExpressConnect for Oracle

Note Although this guide describes homogeneous replication scenarios, the appropriate combination of Replication Agent and ECDA can be used for replication between different types of primary and replicate data servers.

Audience

This book is for anyone who needs to manage or administer a Sybase replication system with non-Sybase databases, or administer the non-Sybase databases in a Sybase replication system. This may include:

- Database administrators
- Network administrators
- System administrators

How to use this book

This book is organized as follows:

- Chapter 1, “Setting Up Replication for Oracle” describes the quick-start procedure to install and configure a sample replication environment for Oracle.
- Chapter 2, “Setting Up Replication for Microsoft SQL Server” describes the quick-start procedure to install and configure a sample replication environment for Microsoft SQL Server.

-
- Chapter 3, “Setting Up Replication for IBM DB2 Universal Database” describes the quick-start procedure to install and configure a sample replication environment for IBM DB2 Universal Database.

Use the product documentation to look up detailed information about Replication Server, Replication Agent, ExpressConnect, and ECDA commands and configuration parameters.

Related documents

Replication Server, Replication Agent, ECDA, and ExpressConnect See the product documentation for details on how to install and use Replication Server and the Replication Server Options components.

Primary data server Make sure that you have appropriate documentation for the primary data server that you use with the Sybase replication system.

Java environment The Replication Agent requires a Java Runtime Environment (JRE) on the Replication Agent host machine.

- The *Replication Agent Release Bulletin* contains the most up-to-date information about Java and JRE requirements.
- Java documentation available from your operating system vendor describes how to set up and manage the Java environment on your platform.

Use the product documentation to look up detailed information about Replication Server, Replication Agent, ExpressConnect, and ECDA commands and configuration parameters.

Other sources of information

Use the Sybase Getting Started CD and the Sybase Product Manuals Web site to learn more about your product:

- The Getting Started CD is included with your software and contains release bulletins, installation guides in PDF format, and other documents or updated information. To read or print documents on the Getting Started CD, you need Adobe Acrobat Reader, which you can download at no charge from the Adobe Web site using a link provided on the CD.

You can also access the documents available on the Getting Started CD from the Sybase Product Manuals Web site.

- The Sybase Product Manuals Web site, which can be accessed using a standard Web browser, includes the Replication Server documents that are not included in the Getting Started CD. In addition to product manuals, you will find links to EBFs/Maintenance, Technical Documents, Case Management, Solved Cases, newsgroups, and the Sybase Developer Network.

To access the Sybase Product Manuals Web site, go to Product Manuals at <http://www.sybase.com/support/manuals/>.

Sybase certifications on the Web

Technical documentation at the Sybase Web site is updated frequently.

❖ Finding the latest information on product certifications

- 1 Point your Web browser to Technical Documents at <http://www.sybase.com/support/techdocs/>.
- 2 Click Partner Certification Report.
- 3 In the Partner Certification Report filter select a product, platform, and timeframe and then click Go.
- 4 Click a Partner Certification Report title to display the report.

❖ Finding the latest information on component certifications

- 1 Point your Web browser to Availability and Certification Reports at <http://certification.sybase.com/>.
- 2 Either select the product family and product under Search by Base Product; or select the platform and product under Search by Platform.
- 3 Select Search to display the availability and certification report for the selection.

❖ Creating a personalized view of the Sybase Web site (including support pages)

Set up a MySybase profile. MySybase is a free service that allows you to create a personalized view of Sybase Web pages.

- 1 Point your Web browser to Technical Documents at <http://www.sybase.com/support/techdocs/>.
- 2 Click MySybase and create a MySybase profile.

Sybase EBFs and software maintenance

❖ Finding the latest information on EBFs and software maintenance

- 1 Point your Web browser to the Sybase Support Page at <http://www.sybase.com/support>.
- 2 Select EBFs/Maintenance. If prompted, enter your MySybase user name and password.
- 3 Select a product.

-
- 4 Specify a time frame, and click Go. A list of EBF/Maintenance releases appears.

Padlock icons indicate that you do not have download authorization for certain EBF/Maintenance releases because you are not registered as a Technical Support Contact. If you have not registered, but have valid information provided by your Sybase representative or through your support contract, click Edit Roles to add the “Technical Support Contact” role to your MySybase profile.

- 5 Click the Info icon to display the EBF/Maintenance report, or click the product description to download the software.

Style conventions

The following style conventions are used in this book:

- In a sample screen display, commands that you should enter exactly as shown appear like this:

```
ra_init
```

- In the regular text of this document, variables or user-supplied words appear like this:

Specify the *value* option to change the setting of the configuration parameter.

- In a sample screen display, variables or words that you should replace with the appropriate value for your site appear like this:

```
resume connection to pds.pdb
```

Here, *pds* and *pdb* are the variables you should replace.

- In the regular text of this document, names of programs, utilities, procedures, and commands appear like this:

Use the `pdb_init` command to initialize the primary database.

- In the regular text of this document, names of database objects (tables, columns, stored procedures, and so on) appear like this:

Select the price column in the widgets table.

- In the regular text of this document, names of datatypes appear like this:

Use the `date` or `datetime` datatype.

- In the regular text of this document, names of files and directories appear like this:

Log files are located in the `$SYBASE/RAX-15_5/inst_name/log` directory.

Syntax conventions

Table 1 shows the syntax conventions used in this book:

Table 1: Syntax conventions

Key	Definition
{ }	Curly braces indicate that you must choose at least one of the enclosed options. Do not type the braces when you enter the command.
[]	Brackets mean that choosing one or more of the enclosed options is optional. Do not type the brackets when you enter the command.
()	Type parentheses as part of the command.
	The vertical bar means you can select only one of the options shown.
,	The comma means you can choose as many of the options shown as you like, separating your choices with commas that you type as part of the command.

In reference sections of this document, statements that show the syntax of commands appear like this:

```
ra_config [param [, value]]
```

The words *param* and *value* in the syntax are variables or user-supplied words.

Character-case conventions

The following character-case conventions are used in this book:

- All command syntax and command examples are shown in lowercase. However, command names are not case-sensitive. For example, RA_CONFIG, Ra_Config, and ra_config are equivalent.
- Names of configuration parameters are case-sensitive. For example, Scan_Sleep_Max is not the same as scan_sleep_max, and the former would be interpreted as an invalid parameter name.
- Database object names are not case-sensitive in commands. However, to use a mixed-case object name in a command (to match a mixed-case object name in the primary database), delimit the object name with quote characters. For example:

```
pdb_get_tables "TableName"
```

Accessibility features

This document is available in an HTML version that is specialized for accessibility. You can navigate the HTML with an adaptive technology such as a screen reader, or view it with a screen enlarger.

Replication Server Options and the HTML documentation have been tested for compliance with U.S. government Section 508 Accessibility requirements. Documents that comply with Section 508 generally also meet non-U.S. accessibility guidelines, such as the World Wide Web Consortium (W3C) guidelines for Web sites.

The online help for this product is also provided in HTML, which you can navigate using a screen reader.

Note You might need to configure your accessibility tool for optimal use. Some screen readers pronounce text based on its case; for example, they pronounce ALL UPPERCASE TEXT as initials, and MixedCase Text as words. You might find it helpful to configure your tool to announce syntax conventions. Consult the documentation for your tool.

For information about how Sybase supports accessibility, see Sybase Accessibility at <http://www.sybase.com/accessibility>. The Sybase Accessibility site includes links to information on Section 508 and W3C standards.

For a Section 508 compliance statement for Replication Server Options, see Sybase Accessibility at http://www.sybase.com/detail_list?id=52484.

If you need help

Each Sybase installation that has purchased a support contract has one or more designated people who are authorized to contact Sybase Technical Support. If you cannot resolve a problem using the manuals or online help, please have the designated person contact Sybase Technical Support or the Sybase subsidiary in your area.

Setting Up Replication for Oracle

This chapter identifies the components that are required to implement a Sybase replication system for Oracle, as well as an overview of the tasks and instructions for installing and configuring a sample replication environment for Oracle.

Topic	Page
Sybase replication system	1
Prerequisites	2
Installing replication components	3
Configuring replication components	13
Testing replication	31

Note Use the procedures in this chapter only for proof-of-concept (POC) or testing, not for production. Only basic Oracle features are addressed in the following scenario. In particular, Oracle Automatic Storage Management (ASM) and Real Application Clusters (RAC) are not addressed here. However, Replication Agent does support these features. See the *Replication Agent Primary Database Guide*.

Sybase replication system

These components are required to implement a Sybase replication system for Oracle:

- A primary Oracle data server
- A replicate Oracle data server
- A Replication Server
- The Replication Server Options components:
 - Replication Agent

- ExpressConnect for Oracle (ECO)

Figure 1-1 illustrates a Sybase replication system with Oracle servers. It shows the flow of data between the data servers and the Replication Agent, Replication Server, and ECO.

Figure 1-1: Sybase replication system for Oracle

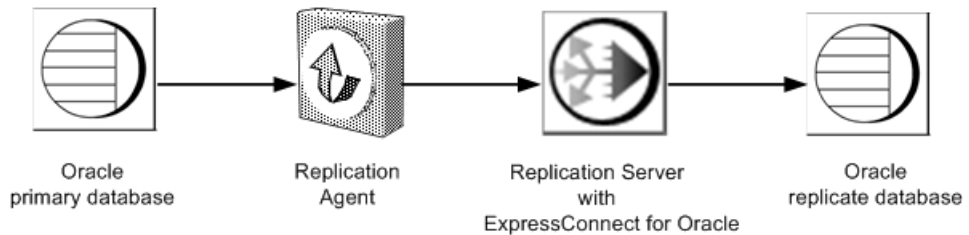

Prerequisites

Before you begin setting up the replication system, be familiar with Oracle data servers and have an understanding of Sybase replication. In addition:

- You must have a valid license for Replication Server and Replication Server Options.
- Oracle Database 10g or 11g Enterprise Edition must be installed and configured to serve as the source (primary) database and as the target (replicate) database from which Replication Agent replicates transactions.
- Oracle JDBC™ thin driver for Oracle 10g or 11g and for JDK 1.4 and 1.5 must be installed.
- TCP/IP connectivity must be available.
- Any OS patches required for Java 6.0 have been installed.
- The Replication Agent must have direct access to the Oracle online and archived *redo* logs.

During this procedure, Sybase recommends that you do not use Replication Server reserved words for object names and connection names. A complete list of reserved words is in the *Replication Server Reference Manual*.

System requirements

The target computer on which you are installing the replication components must meet the following memory and disk space requirements:

For Windows

Table 1-1: Windows memory and disk requirements

Components	Memory (RAM)	Disk space
Replication Server	512MB	380MB
ExpressConnect for Oracle	125MB	105MB
Replication Agent	512MB	300MB

For UNIX

Table 1-2: UNIX memory and disk requirements

Components	Memory (RAM)	Disk space
Replication Server	512MB	520MB
ExpressConnect for Oracle	125MB	200MB
Replication Agent	512MB	300MB

For Linux

Table 1-3: Linux memory and disk requirements

Components	Memory (RAM)	Disk space
Replication Server	512MB	400MB
ExpressConnect for Oracle	125MB	200MB
Replication Agent	512MB	300MB

To improve performance by avoiding multiple network hops, Sybase recommends that Replication Server, ECO, and the target database reside on the same machine.

See *Replication Server Options 15.5 Release Bulletin*.

Installing replication components

The replication of sequences is not covered in this document. To set up sequence replication, see the *Replication Agent Installation Guide* and the *Replication Agent Primary Database Guide*.

Before you start

Before installing replication components, identify the Sybase installation directories and obtain the installation software.

Identifying the Sybase installation directory

Replication Agent, Replication Server, and ECO are installed in the same base directory, which is identified by the SYBASE environment variable. Select a path on a host drive to be the recipient of the Sybase installation and configuration activities.

Accessing products from the SPDC

If you are not using installation CDs, go to the Sybase Product Download Center (SPDC) Web site to obtain replication software.

❖ Downloading the replication software

Note This procedure requires you repeat steps to download two products: Replication Server and Replication Server Options.

You must have a login ID and password to download software from the SPDC.

- 1 Go to SPDC at <https://sybase.subscribenet.com/control/sybs/login> and enter your login ID and password.

The Product List page appears.

- 2 Select Replication Server.

The high-level Product Information page appears.

- 3 Select Replication Server again.

The detailed Product Information page appears.

- 4 Select the Replication Server software you need by primary database, version, and platform (return later to this detailed Product Information page to select Replication Server Options software).

The Software Terms and Conditions page appears, listing countries and regions.

- 5 Either:

- Select I Agree to accept the terms without reading them, go to the Product Download Page, and continue with step 6, or
 - Select your country or region to read the terms.
The software licence agreement for the software appears. Read the terms and either:
 - Select I Agree to accept the terms, go to the Product Download Page, and continue with step 6, or
 - Select Cancel to return to the high-level Product Information page.
- 6 The Product Download Page lists the software and documentation for the product. Select FTP Download or Advanced Download Options for the Replication Server software to download and save the compressed files to your local drive.

Note For each product, the documentation download contains installation-related documents, and the SyBooks download contains the rest of the documentation set.

- 7 Return to the detailed Product Information page that you accessed in step 3 and select the Replication Server Options software by primary database, version, and platform.
The Software Terms and Conditions page appears, listing countries and regions.
- 8 Navigate the Software Terms and Conditions pages as you did in step 5.
- 9 At the Product Download Page, select FTP Download or Advanced Download Options for the components of Replication Server Options to download and save the compressed files to your local drive:
- Replication Agent 15.5
 - ExpressConnect for Oracle
- 10 Uncompress and extract all the installation images to your local drive.

Installing ExpressConnect for Oracle

This section describes the steps for installing ExpressConnect for Oracle (ECO) using the GUI mode

- 1 Launch the setup program.
 - On Windows – the setup program should start automatically. If it does not, select Start | Run and browse to *setup.exe*.
 - On UNIX – enter the following at the command prompt:

```
/cdrom/setup
```

The Welcome window appears. Click Next to proceed.

- 2 Select the geographic location where you are installing to display the agreement appropriate to your region. Read the End-user License and Copyright Agreement. Select “I agree to the terms of the Sybase license for the install location specified” and click Next.
- 3 Enter the directory where you want to install ECO.

Note ECO must be installed in the same directory as Replication Server.

Accept the default installation directory or click Choose to select another directory. If the directory does not exist, the installation program prompts you to create it. Click Yes.

If the destination directory exists, you receive a warning message that you are installing into an existing directory. Click Next.

- 4 If the installer does not detect an existing installation of Replication Server in the specified directory, it prompts an error message. Click Previous to go back and choose another installation directory and then click Next.
- 5 The installation summary window displays. Review the information, and click Install.
- 6 When the installation is complete, a message appears indicating that ECO has been successfully installed. Click Done.

Installing Replication Server

If Replication Server is already installed, go to “Installing ExpressConnect for Oracle” on page 5.

While installing Replication Server:

- Allocate a disk partition of at least 20MB for each Replication Server you are installing. You can add more partitions later, if necessary. Check each partition to make sure it is available and has write permissions.

- Allocate the entire partition to the Replication Server. If you allocate only a portion of the partition to Replication Server, you cannot use the remainder for any other purpose.

❖ **Installing Replication Server**

- 1 Use one of the following methods to download Replication Server software.
 - After following the download instructions in “Accessing products from the SPDC” on page 4, go to the location where you extracted the Replication Server 15.5 installation image, or
 - Insert the Replication Server CD in your CD drive.
- 2 Execute the setup routine.
 - For UNIX or Linux (GUI mode):

```
./setup
```
 - For Windows:

```
setup
```
- 3 If you see an error message saying that there is not enough temporary disk space, add the following to your setup command:
 - For UNIX or Linux:

```
./setup -is:tempdir tempDirectory
```
 - For Windows:

```
setup -is:tempdir tempDirectory
```

Here, *tempDirectory* is a directory with at least 100MB of disk space that the installation program can use.
- 4 On the Welcome window, click Next.
- 5 Select a geographic location that displays the license agreement. Select I agree, and click Next.
- 6 Enter the directory where you want to install Replication Server:
 - If the directory does not exist, the installation program prompts you to create it. Click Yes.
 - If the destination directory exists, you receive a warning message that you are installing into an existing directory. Click Yes.
- 7 Select Typical for the installation setup type, and click Next.

8 The installation program displays a summary of what is to be installed. Click Next.

9 The installation program starts to install Replication Server, displaying the progress status. You may see the following message,

```
There are newer files already installed and do you
want to replace them?
```

Click No to All.

10 When you receive a message indicating that Replication Server software has successfully installed, click Next.

Note This procedure uses the SAMPLE_RS Replication Server.

11 The SySAM License Server window opens and displays this prompt:

```
Will licenses be obtained from the License Server?
```

Respond based on how you set up your environment and use the license obtained from the Software Product Download Center (SPDC) Web site for Replication Server.

Click Next.

12 The SySAM notification window prompts you to configure your server for e-mail notification. When configuration is enabled, you receive information about license management events that require attention. Select Yes, and either accept the default values that are supplied, or enter values for the following:

- SMTP server host name
- SMTP server port number
- Sender e-mail address
- Recipient e-mail address
- Message severity level of an event that triggers an e-mail message. Your choices are:
 - Informational
 - Warning
 - Error

If you choose not to have e-mail alerts or severity messages logged, select No.

Click Next.

13 To start a sample Replication Server, select Yes, and click Next.

14 This information appears and should be recorded:

This page contains detailed information regarding the sample Replication Server. Please record this information.

The sample Replication Server will be called `SAMPLE_RS` and will run on port 11752. It will be configured with a user of `sa` and no password.

The sample Replication Server will use an embedded RSSD called `SAMPLE_RS_ERSSD` that runs on port 11751. It will be configured with a user of `SAMPLE_RS_RSSD_prim` and a password of `SAMPLE_RS_RSSD_prim_ps`.

The installer has updated the appropriate interfaces file or `sql.ini` file.

All files and logs associated with the sample Replication Server will be located in the directory `<samp_repserver>`.

The sample Replication Server will be configured using the file `<SAMPLE_RS.res>`.

Here, `<samp_repserver>` and `<SAMPLE_RS.res>` are paths to the sample Replication Server and sample Replication Server configuration file, respectively.

Click Next.

15 When the sample Replication Server is running and an “Installation was successful” message appears, click Finish.

❖ **Verifying the installation**

1 Change to the directory where you installed Replication Server.

2 Set the environment variables by sourcing the `SYBASE.csh` file (UNIX or Linux) or by executing the `SYBASE.bat` file (Windows).

3 Use `isql` to log in to Replication Server:

```
isql -Usa -P -SSAMPLE_RS
```

4 Verify the Replication Server version:

```
admin version
```

go

- 5 Exit the isql session with the quit command.

Installing Replication Agent

If Replication Agent is already installed, go to “Installing Replication Server” on page 6.

Install Replication Agent for Oracle on a server where it can directly access the Oracle online *redo* logs and the archived *redo* logs.

Installing the Replication Agent creates a directory structure containing the Replication Agent binaries, scripts, JRE, and associated files. There are no configuration steps during installation.

❖ Installing Replication Agent software

- 1 Use one of the following methods to install the software:
 - After following the download instructions in “Accessing products from the SPDC” on page 4, go to the location where you extracted the Replication Agent 15.5 installation image, or
 - Insert the Replication Agent CD into your CD drive.
- 2 Execute the setup routine.
 - For Windows:

```
setup
```
 - For UNIX or Linux:

```
./setup
```
- 3 If you see an error message saying that there is not enough temporary disk space, add the following to your setup command:
 - For Windows:

```
setup -is:tempdir tempDirectory
```
 - For UNIX or Linux:

```
./setup -is:tempdir tempDirectory
```

Here, *tempDirectory* is a directory with at least 100MB of disk space that the installation program can use.

Note If you are installing from a remote machine and do not have an X-Windows client, execute `./setup -console`, to run in console mode.

- 4 On the Welcome window, click Next.
- 5 Select a geographic location that displays the license agreement. Select “I agree to the terms of the Sybase license for the install location,” and click Next.
- 6 Enter the directory where you want to install Replication Agent:
 - If the directory does not exist, the installation program prompts you to create it. Click Yes.
 - If the destination directory exists, you receive a warning message that you are installing into an existing directory. Click Next.
- 7 Select Typical for the installation setup type, and click Next.
- 8 On the Sybase Software Asset Management License Server window, use one of these options to enter the license:
 - Specify license keys – click Browse to select the license file.
Alternatively, copy and paste the license information directly in the license pane. Click Next to proceed.
 - Use previously deployed license server – if you have a previously deployed license server, enter the host name of the machine where the license server is running, and the port number if the port number you are using is not default. Click Next.
 - Continue installation without a license key – if you do not have a license, you can select this option, and click Next to proceed. The installer allows you to install and use Replication Agent without a license for a grace period of 30 days. To continue using Replication Agent after the end of the grace period, obtain valid license from the SPDC, and install it.

For more information on SySAM licensing, see the *Sybase Software Asset Management Users Guide*.

- 9 The SySAM notification window prompts you to configure your server for e-mail notification. When configuration is enabled, you receive information about license management events that require attention. At the SySAM notification window, do one of the following:
 - Select Yes and either accept the default values that are supplied, or enter values for the following:
 - SMTP server host name
 - SMTP server port number
 - Sender e-mail address
 - Recipient e-mail address
 - Message severity level of an event that triggers an e-mail message. Your choices are:
 - Informational
 - Warning
 - Error
 - If you choose not to have e-mail alerts or severity messages logged, select No.

Click Next.

- 10 The installation program displays a summary of what is to be installed. Click Install.
- 11 The installation program starts to install Replication Agent, displaying the progress status. Click No to All, if you see the following message:

```
There are newer files already installed and do you
want to replace them?
```
- 12 When you receive a message indicating that Replication Agent was successfully installed, click Done.

❖ **Verifying the installation**

- 1 Change to the directory where you installed Replication Agent.
- 2 Set the environment variables by sourcing the *SYBASE.csh* file (UNIX or Linux) or by executing the *SYBASE.bat* file (Windows).
- 3 Change to *\$SYBASE/RAX-15_5/bin* (UNIX or Linux) or *%SYBASE%\RAX-15_5\bin* (Windows).
- 4 Obtain the Replication Agent version string.

- For UNIX or Linux:

```
./ra.sh -v
```

- For Windows:

```
ra -v
```

If Replication Agent installs successfully, you see the Sybase copyright and the Replication Agent version string.

Configuring replication components

This section describes the tasks you must perform to configure each of the replication component in the replication system.

Configuring ExpressConnect for Oracle

ExpressConnect for Oracle (ECO) is an embedded library loaded by Replication Server for Oracle replication. Server connectivity for ECO is configured via Replication Server using the `create connection` and `alter connection` commands. Thus, there is no separate configuration required for ECO. For information on how to configure Replication Server, see “Configuring Replication Server” on page 13.

Configuring Replication Server

Configuring Replication Server includes:

- 1 Configuring Replication Server for replication to the target data server
- 2 Configuring Replication Server for replication from the primary database

Configuring Replication Server for replication to the target data server

❖ Creating a Replication Server connection

- 1 Navigate to the `$$SYBASE/RAX-15_5/scripts/oracle` (UNIX or Linux) or `%SYBASE%\RAX-15_5\scripts\oracle` (Windows) directory.

- 2 Make a copy of the *oracle_create_rs_standby_connection.sql* script named *my_oracle_create_rs_standby_connection.sql*.
- 3 Before executing the *my_oracle_create_rs_standby_connection.sql* script against your Replication Server, change all occurrences of value *{rds}.{rdb}* to the name of the connection that Replication Server uses to connect to ECO where:
 - *rds* is the Oracle SID name.
 - *rdb* is any valid identifier. Sybase recommends that you use the Oracle SID name.
 - *maintuser* and *password* are the user name and password created in ECO.

For example:

```
create connection to OracleSID_name.OracleSID_name
using profile rs_oracle_to_oracle;eco
set username to maintuser
set password to "password"

go
```

Note In the previous example, *password* is a Replication Server reserved word and therefore, must be enclosed in double quotes.

If you are not creating the connection using one of the Replication Server's Oracle ECO connection profiles, set *dsi_proc_as_rpc* to 'on' in the create connection command. For example,

```
create connection to OracleSID_name.OracleSID_name
set error class <error_class>
set function string class <function_class>
set username <userid>
set password <password>
set dsi_dataserver_make to 'ora'
set dsi_dataserver_type to 'oci'
set batch to 'off'
set dsi_proc_as_rpc to 'on'
```

If you are using one of Replication Server's Oracle ECO connection profiles, *dsi_proc_as_rpc* is enabled by default.

- 4 For configuring the server connectivity for ECO, copy the *tnsnames.ora* file to the *RS_installation_directory\REP-15_5\connector\oraoci\network\admin* directory.

- 5 Create the connection to the replicate database:

```
isql -Usa -P -SSAMPLE_RS -i my_oracle_create_rs_standby_connection.sql
```

- 6 Log in to SAMPLE_RS and verify the Replication Server connection to the replicate database:

```
isql -Usa -P -SSAMPLE_RS
admin who
go
```

You should see a message returned for the DSI connection *{rds}.{rdb}*. Verify that the status is “Awaiting Message” or “Awaiting Command.”

- 7 Exit the isql session with the quit command.

Configuring Replication Server for replication from the primary database

This section describes the configuration steps required for replication from the primary database. It includes:

- Creating a Replication Server connection to the primary database
- Creating a database replication definition
- Creating the database replication subscription

❖ Creating a Replication Server connection to the primary database

- 1 Go to the `$SYBASE/RAX-15_5/scripts/oracle` (UNIX or Linux) or `%SYBASE%\RAX-15_5\scripts\oracle` directory (Windows).

- 2 Make a copy of the `oracle_create_rs_primary_connection.sql` script named `my_oracle_create_rs_primary_connection.sql`.

```
cp oracle_create_rs_primary_connection.sql
my_oracle_create_rs_primary_connection.sql
```

- 3 Before executing the `my_oracle_create_rs_primary_connection.sql` script against your Replication Server, change all occurrences of value `{pds}.{pdb}` to the name of the Replication Server connection used for the connection from Replication Agent for Oracle, where:

- `pds` is the name of the Oracle server.
- `pdb` is the Oracle System ID (SID).

For example, *NY.NYora92*.

Note Save these values to be used later for the *rs_source_ds* and *rs_source_db* parameters in the Replication Agent *oracle.rs* file.

- 4 Change *sys* and *sys_pwd* to the user ID and password of the Oracle user who must have permission to apply DML operations against all user tables to be replicated, where:
 - *sys* is the user ID of the Oracle user (*sys*).
 - *sys_pwd* is the password of the Oracle user (*change_on_install*).

Note This user must be a valid user in the Oracle database.

The following example creates a Replication Server connection to the primary database:

```
create connection to NY.NYora92
set error class rs_sqlserver_error_class
set function string class rs_oracle_function_class
set username sys
set password change_on_install
with log transfer on, dsi_suspended
go
```

- 5 Execute the script in Replication Server:

```
isql -Usa -P -SSAMPLE_RS -i my_oracle_create_rs_primary_connection.sql
```

A message appears that indicates the Replication Server connection to the primary database has been created.

❖ Creating the database replication definition

- 1 Navigate to the *\$SYBASE/RAX-15_5/scripts/sybase* (UNIX or Linux) or *%SYBASE%\RAX-15_5\scripts\sybase* (Windows) directory.
- 2 Make a copy of the *rs_create_test_db_repdef.sql* script named *my_rs_create_db_repdef.sql*.

```
cp rs_create_test_db_repdef.sql
my_rs_create_db_repdef.sql
```

- 3 Before executing the *my_rs_create_db_repdef.sql* script, change all occurrences of value *{pds}.{pdb}* to the name of the connection string you defined for the primary database, where:

- *pds* is the name of the Oracle server.
- *pdb* is the Oracle System ID (SID).

For example, *NY.NYora92*.

Note Save these values to be used later for the *rs_source_ds* and *rs_source_db* parameters in the Replication Agent *oracle.rs* file.

This is a database replication definition example:

```
create database replication definition NY_repdef1
with primary at NY.NYora92
replicate DDL
go
```

- 4 Connect to the Replication Server and enter:

```
isql -Usa -P -SSAMPLE_RS -i my_rs_create_db_repdef.sql
```

A message appears that indicates the database replication definition has been created.

❖ Creating the database replication subscription

- 1 Make a copy of the *rs_create_test_db_sub.sql* script named *my_rs_create_db_sub.sql*.

```
cp rs_create_test_db_sub.sql
my_rs_create_db_sub.sql
```

- 2 Before executing the *my_rs_create_db_sub.sql* script, change all occurrences of value *{pds}.**{pdb}* and *{rds}.**{rdb}* to the appropriate connection name, where:

- *pds* is the name of the Oracle server
- *pdb* is the Oracle System ID (SID)
- *rds* is the Oracle System ID (SID)
- *rdb* is any valid identifier. Sybase recommends that you use the Oracle SID

Note Save the values of *pds* and *pdb* to be used later for the *rs_source_ds* and *rs_source_db* parameters in the Replication Agent *oracle.rs* file.

Here is an example of create database replication subscription:

```
create subscription NY_sub1
```

```
for database replication definition NY_repdef1
with primary at NY.NYora92
with replicate at DCOServer.oratest2
without materialization
go
```

- 3 Connect to Replication Server and execute:

```
isql -Usa -P -SSAMPLE_RS -i my_rs_create_db_sub.sql
```

A message appears that indicates the subscription is being created.

Configuring Replication Agent

Configuring Replication Agent involves:

- 1 Configuring and verifying the primary Oracle database for replication
- 2 Creating the Replication Agent instance
- 3 Verify the Replication Agent instance
- 4 Initializing the Replication Agent instance

Configuring and verifying the primary Oracle database for replication

Before you install Replication Agent, configure the primary Oracle database for replication.

To ensure that the Oracle *redo* log data is not overwritten before it is read by the Replication Agent:

- Verify the current archive setting of the redo logs.
- Verify the supplemental logging of primary key data.
- Create an Oracle user and grant Oracle permissions.
- Verify the Oracle user roles created by the Replication Agent

❖ Verifying the current archive setting of the redo logs

Redo logs are used by Oracle to maintain a log infrastructure. The steps described below verify that the feature is turned on and, if not, indicate how to switch on the *redo* logging. Turn this feature on only in the primary database.

- 1 Use SQLPLUS to connect to Oracle as a system administrator.
- 2 From SQLPLUS, run this command:

```
select log_mode from v$database;
```

- If the archive log is on, the result should be:

```
LOG_MODE
-----
ARCHIVELOG
```

- 3 To turn on log archiving:

```
shutdown;
startup mount;
alter database archivelog;
alter database open;
```

See the *Replication Agent Primary Database Guide*.

❖ Verifying the supplemental logging of primary key data

By default, Oracle does not log primary keys and unique indexes to its logging infrastructure. For successful replication of all table values, you must log these values. To verify whether this information is currently being recorded in the logging system:

- 1 Use SQLPLUS to connect to Oracle as a system administrator by running the following command from SQLPLUS:

```
SELECT SUPPLEMENTAL_LOG_DATA_MIN,
SUPPLEMENTAL_LOG_DATA_PK,
SUPPLEMENTAL_LOG_DATA_UI
FROM V$DATABASE;
```

If logging of primary key and unique index values is enabled, the return values are:

```
SUP SUP SUP
--- --- ---
YES YES YES
```

- 2 If the result is different, turn on supplemental logging by executing these commands:

```
ALTER DATABASE ADD SUPPLEMENTAL LOG DATA (PRIMARY
KEY, UNIQUE INDEX) COLUMNS;
ALTER DATABASE ADD SUPPLEMENTAL LOG DATA;
```

❖ **Creating an Oracle user and grant permissions**

An Oracle database user must be created for use by Replication Agent when connected to the primary database.

Note Permission to grant access to objects owned by “SYS” may require the command to be executed by an Oracle user with sysdba privileges.

- Use SQLPLUS to connect to the primary database as a system administrator and run the following commands to create an Oracle user named “RA_USER,” specified by pds_username, with the password “sybase,” and grant permissions to the user:

```
CREATE USER RA_USER PROFILE "DEFAULT" IDENTIFIED
BY "sybase" DEFAULT TABLESPACE "USERS" ACCOUNT
UNLOCK;
GRANT "CONNECT" TO RA_USER;
GRANT "RESOURCE" TO RA_USER;
GRANT "SELECT_CATALOG_ROLE" TO RA_USER;
GRANT ALTER SESSION TO RA_USER;
GRANT ALTER SYSTEM TO RA_USER;
GRANT EXECUTE ON "SYS"."DBMS_FLASHBACK" TO RA_USER;
GRANT EXECUTE ON "SYS"."DBMS_LOCK" TO RA_USER;
GRANT ALTER ANY PROCEDURE TO RA_USER;
GRANT CREATE SESSION TO RA_USER;
GRANT CREATE TABLE TO RA_USER;
GRANT ALTER ANY TABLE TO RA_USER;
GRANT DROP ANY TABLE TO RA_USER;
GRANT CREATE PROCEDURE TO RA_USER;
GRANT DROP ANY PROCEDURE TO RA_USER;
GRANT CREATE PUBLIC SYNONYM TO RA_USER;
GRANT DROP PUBLIC SYNONYM TO RA_USER;
GRANT SELECT ON SYS.OBJ$ TO RA_USER;
GRANT SELECT ON SYS.LOB$ TO RA_USER;
GRANT SELECT ON SYS.COLLECTION$ TO RA_USER;
GRANT SELECT ON SYS.CON$ TO RA_USER;
GRANT SELECT ON SYS.COLTYPE$ TO RA_USER;
GRANT SELECT ON SYS.COL$ TO RA_USER;
GRANT SELECT ON SYS.CDEF$ TO RA_USER;
GRANT SELECT ON SYS.SNAP$ TO RA_USER;
GRANT SELECT ON SYS.TS$ TO RA_USER;
GRANT SELECT ON SYS.USER$ TO RA_USER;
GRANT SELECT ON SYS.SEQ$ TO RA_USER;
GRANT SELECT ON SYS.IND$ TO RA_USER;
GRANT SELECT ON SYS.TAB$ TO RA_USER;
GRANT SELECT ON SYS.TABPART$ TO RA_USER;
```

```

GRANT SELECT ON SYS.TABCOMPART$ to RA_USER;
GRANT SELECT ON SYS.TABSUBPART$ to RA_USER;
GRANT SELECT ON SYS.NTAB$ to RA_USER;
GRANT SELECT ON SYS.INDPART$ to RA_USER;
GRANT SELECT ON SYS.INDCOMPART$ to RA_USER;
GRANT SELECT ON SYS.INDSUBPART$ to RA_USER;
GRANT SELECT ON SYS.LOBCOMPPART$ to RA_USER;
GRANT SELECT ON SYS.LOBFRAF$ to RA_USER;
GRANT SELECT ON SYS.MLOG$ to RA_USER;
GRANT SELECT ON SYS.PROCEDUREINFO$ to RA_USER;
GRANT SELECT ON SYS.ARGUMENT$ to RA_USER;
GRANT SELECT ON SYS.TYPE$ to RA_USER;
GRANT SELECT ON SYS.ATTRIBUTE$ to RA_USER;
GRANT SELECT ON SYS.CCOL$ to RA_USER;
GRANT SELECT ON "SYS"."RECYCLEBIN$" TO RA_USER;
GRANT SELECT ON "SYS"."OPQTYPE$" TO RA_USER;

```

See the *Replication Agent Primary Database Guide*.

❖ Verifying the Oracle user roles created by the Replication Agent

- As described in the previous section, the following Oracle commands can be issued to validate the required Oracle settings.

Use SQLPLUS to run the following command as the new Oracle user:

```

select GRANTED_ROLE from USER_ROLE_PRIVS;
GRANTED_ROLE
-----
CONNECT
RESOURCE
SELECT_CATALOG_ROLE

```

In addition, the user who starts the Replication Agent instance must have read access to the Oracle redo log files and the Oracle archive directory that contains the archive log files to be accessed for replication. If the Replication Agent is configured to remove old archive files, the user must have update authority to the directory and the archive log files.

Creating the Replication Agent instance

A single installation of the Replication Agent can support replication from multiple databases, however, one Replication Agent instance is needed for each Oracle database that is to be replicated.

❖ **Preparing the Replication Agent instance**

- 1 Obtain the Oracle JDBC driver from Oracle and update the CLASSPATH environment variable.

To find the JDBC connection that communicates with the primary Oracle instance, locate the JDBC driver that was available when the Oracle release was originally created, usually found at:

```
$ORACLE_HOME/jdbc/lib/ojdbc14.jar
```

Replication Agent may require a newer version of the JDBC driver, which can be found at

http://technet.oracle.com/software/tech/java/sqlj_jdbc/content.html.

- 2 Add the JDBC driver to the CLASSPATH environment variable. For example, you can append the existing CLASSPATH to the new JDBC driver and add the following command to the .login script of a UNIX and Linux user:

```
setenv CLASSPATH /path_name/ojdbc14.jar:$CLASSPATH
```

For a Windows user, add the following to the CLASSPATH environment variable:

```
set CLASSPATH=path_name\jdbc\lib\ojdbc14.jar;  
%CLASSPATH%
```

- 3 Record the location of the *tnsnames.ora* file and record the connection name from that file for the Replication Agent to use to connect to the Oracle primary database. You can find these values from any machine where an Oracle SQLPLUS session can be used to connect to the desired Oracle instance. The ORACLE_SID is from the environment variable, \$ORACLE_SID.

Record the ORACLE_SID value for the instance you want to connect to.

- 4 (Optional) If your operating system has a Java 6.0.x-compatible JRE or JDK installed, you can use the Oracle iSQL (the browser-based interface to SQL*PLUS) demo items to connect to Oracle using the JDBC driver and to verify the connection information.

To perform this validation, see “Verifying a JDBC Client Installation” in the *Oracle JDBC Developer's Guide and Reference Guide*.

- 5 Obtain a local copy of the Oracle *timezone* file, so Replication Agent can correctly process the Oracle timestamp with the *timezone* datatype.

Note This step is required only if the Replication Agent is on a machine (host) other than the Oracle host and does not have access to the Oracle *timezone* file.

There are two *timezone* files in the `$ORACLE_HOME/oracore/zoneinfo` (UNIX or Linux) or `%ORACLE_HOME%\oracore\zoneinfo` (Windows) directory:

- The *timezone.dat* binary file is the default file that contains the most commonly used time zones.
- The *timezlg.dat* binary file contains a larger set of defined time zones.

The Oracle instance uses the *timezone* file from the `ORA_TZFILE` environment variable. If `ORA_TZFILE` is not set, use the default *timezone* file.

Determine which *timezone* file is used by the primary Oracle instance and make a copy of that file available on the machine hosting the Replication Agent.

Note These files are Oracle version- and platform-dependent. You cannot use a *timezone* file from a little-endian platform on a big-endian platform, nor can you use a *timezone* file from a version of Oracle that is different than the version of the primary Oracle.

- 6 Locate the Replication Agent for Oracle resource file template.

The majority of configuration values required to create and initialize a Replication Agent can be recorded and stored in a resource file. Using a resource file provides a means to record or retain the configuration information for a Replication Agent instance, allowing an instance to be removed and re-created.

The resource file template (*oracle.rs*) is in the Replication Agent directory `$SYBASE/RAX-15_5/init` (UNIX or Linux) or `%SYBASE%\RAX-15_5\init` (Windows).

- 7 Create an instance resource file:

Copy the resource file template `$SYBASE/RAX-15_5/init/oracle.rs` (UNIX or Linux) or `%SYBASE%\RAX-15_5\init\oracle.rs` (Windows) to another file that contains the configuration information for a new instance, for example, `myra.rs`.

Change the values assigned to properties in the resource file so they match the values required for your environment. The majority of these values are tnsname location, user, and password information for the Oracle, Replication Server, and RSSD connections.

- Set the value of `rs_source_ds` to the value you chose for `pds` in previous procedures.
- Set the value of `rs_source_db` to the value you chose for `pdb` in previous procedures.

The resource file is self-documenting, with each parameter described. See the *Replication Agent Administration Guide*. For a complete list of configuration parameters, see the *Replication Agent Reference Manual*.

Warning! The `rs_source_ds` and the `rs_source_db` values must match the `{pds.pdb}` values of your Replication Server primary connection name that you configured in step 3, in “Creating a Replication Server connection to the primary database” on page 15.

Table 1-4: Resource file parameters

Parameter	Description	Example values
instance name	Any valid name.	myra
admin_port	Port number that Replication Agent uses.	9030 (if in use, select a different port number)
pds_tns_connection	Connection name found in the <code>tnsnames.ora</code> file which identifies the connection information for the primary database.	ORA102.JDOE_HOST.COM
pds_tns_filename	File name identifying the Oracle <code>tnsnames.ora</code> file to be used to identify the connection information for the primary database.	A valid Oracle <code>tnsnames.ora</code> file. For example: <code>/opt/oracle/network/admin/tnsnames.ora</code>
pds_username	User ID that Replication Agent uses to access primary data server.	RA_USER
pds_password	Password for <code>pds_username</code> .	sybase
rs_host_name	Machine where Replication Server is installed.	jdoe_host1
rs_port_number	Port where Replication Server is installed.	11752

Parameter	Description	Example values
rs_username	Replication Server user with CONNECT SOURCE and CREATE OBJECT capabilities.	SAMPLE_RS_ra
rs_password	Password for rs_username.	SAMPLE_RS_ra_ps
rs_charset	Character set that Replication Server is using. Note The value defined for the rs_charset configuration parameter must match the RS_charset value in the Replication Server configuration file, <code>\$SYBASE/REP-15_5/install/<server>.cfg</code> (UNIX or Linux) or <code>%SYBASE%\REP-15_5\install\<server>.cfg</code> (Windows).	<ul style="list-style-type: none"> Windows: cp850 UNIX: iso_1
rs_source_ds	Valid name representing data server of Oracle primary database.	NY
rs_source_db	Valid name representing Oracle primary database.	NYora92
rssd_host_name	Machine where RSSD resides.	jdoe_host1
rssd_port_number	Port number where RSSD resides.	11751
rssd_database_name	Database name for RSSD.	SAMPLE_RS_ERSSD
rssd_username	Valid user for RSSD.	SAMPLE_RS_RSSD_maint
rssd_password	Password for rssd_username.	SAMPLE_RS_RSSD_maint_ps
pdb_timezone_file	Path to the pdb_timezone_file directory that contains the archive redo log files.	<code>/software/oracle/Ora10g</code> <code>/oracore/zoneinfo</code> <code>/timezone.dat</code>
start_instance	Start the instance that was created.	yes
initialize_instance	Initialize the Replication Agent instance.	yes
pdb_include_archives	Enables or disables the use of Oracle archive log files.	USE_DEFAULT
pdb_archive_path	Identifies directory path where Replication Agent expects to find archived Oracle redo log files.	A valid directory path on the machine hosting Replication Agent that points to a location where Oracle puts the archived redo log files

8 Create and execute the new instance resource file:

Note Be sure your CLASSPATH environment variable points to the correct Oracle JDBC driver before proceeding.

- a Validate the settings in the resource file using the -vr parameter.

- On UNIX or Linux:

```
$SYBASE/RAX-15_5/bin/ra_admin.sh -vr myra.rs
```

- On Windows:

```
%SYBASE%\RAX-15_5\bin\ra_admin.bat -vr myra.rs
```

Here, *myra.rs* is the path and name of the resource file. Validation results are returned as one of the following:

- Response-file processing completed
- Response-file processing completed with errors

If any validation fails, the *ra_admin* utility returns an error message and information about the failure. You can repeat the validation process as many times as necessary until it executes without error. No entities are changed or created.

- b After the resource file has been validated, allow the *ra_admin* utility to create and configure the Replication Agent instance, using the *-r* parameter.

- On UNIX or Linux:

```
$SYBASE/RAX-15_5/bin/ra_admin.sh -r myra.rs
```

- On Windows:

```
%SYBASE%\RAX-15_5\bin\ra_admin.bat -r myra.rs
```

Here, *myra.rs* is the path and name of the resource file.

Note If, in your response file, you set *start_instance* to *yes*, your instance is also running. If you set *initialize_instance* to *yes*, your instance is also initialized.

- c Results are returned as either:

- Response-file processing completed
- Response-file processing completed with errors

See the *Replication Agent Administration Guide*.

- 9 If in your resource file you set *start_instance* to *yes* and the log indicates that the Replication Agent instance was started, skip this step, and continue with the next section.

Change to the instance directory and run Replication Agent in the background.

- On UNIX or Linux:

```
cd $SYBASE/RAX-15_5/myra
```

- On Windows:

```
cd %SYBASE%\RAX-15_5\myra
```

Execute the *RUN* file in the background.

Your Replication Agent for Oracle is now running.

Verify the Replication Agent instance

This section describes how to verify a Replication Agent instance, which includes:

- 1 Update the Replication Server *interfaces* (UNIX or Linux) or *sql.ini* (Windows) file with the Replication Agent location.
- 2 Verify the connection to the Replication Agent.
- 3 Verify the Replication Agent connection to Oracle.

❖ Verifying the Replication Agent

- 1 Use *dsedit* to update the Replication Server *interfaces* (UNIX or Linux) or *sql.ini* (Windows) file to include an entry for the Replication Agent location.

Note You can use any Tabular Data Stream™ (TDS) client utility (*isql*, *isqlApp*, or *SQLAdvantage*) that you prefer.

- 2 Verify the connection to the Replication Agent:
 - a Open a command window in the *\$SYBASE* (UNIX or Linux) or *%SYBASE%* (Windows) directory of your Replication Agent installation.
 - b Set the environment variables by sourcing the *SYBASE.csh* file (UNIX or Linux) or by executing the *SYBASE.bat* file (Windows).

- c Log in to Replication Agent:

```
isql -Usa -P -Smyra
```

Note The following verification steps are optional because they were performed when you verified the resource file.

3 Verify the Replication Agent connection to Replication Server:

a Enter:

```
test_connection RS
go
```

b The following appears:

```
Type Connection
----
RS succeeded
(1 row affected)
```

c If the result indicates a failure, either the server is not responding or the connection properties (host, port, user, or password) are incorrect.

Verify the host and port configuration values, and manually log in to the Replication Server as the configured user to determine which property is incorrectly defined.

See the *Replication Agent Administration Guide*.

4 Verify the Replication Agent connection to the primary Oracle database:

a Enter:

```
test_connection PDS
go
```

This message appears:

```
Type Connection
----
PDS succeeded
(1 row affected)
```

b If the result indicates a failure:

- The server is not responding, or
- One of the connection properties is incorrect.

Check the *tnsnames.ora* file and *tnsnames* configuration values, and manually log in to the primary Oracle database as the configured user to find which property is incorrectly defined.

See the *Replication Agent Administration Guide* section titled, “Testing network connectivity.”

Initializing the Replication Agent instance

❖ Initializing the Replication Agent instance

Note If in your resource file you set `initialize_instance` to yes and no errors were received during the creation of the instance, skip Step 1.

- 1 The `pdb_xlog init` command verifies that the primary Oracle database is correctly configured to provide archived logging and supplemental logging, and that the Oracle user ID used by the Replication Agent has the necessary permissions. In addition to creating objects in the database to support stored procedure replication, the `pdb_xlog init` command also initializes the Replication Agent System Database (RASD) by reading schema information, and redo log location information from the primary Oracle database.

To initialize the Replication Agent instance, run:

```

pdb_xlog init
go

```

A message appears, indicating that the procedure was successful.

- 2 Enter:

```

resume
go

```

If the Replication Agent successfully transfers to a replicating state, the following result is returned:

```

State Action
-----
REPLICATING Ready to replicate data.

```

The Replication Agent returns `REPLICATION DOWN` state if an error occurs:

```

1> resume
2> go
Msg 32000, Level 20, State 0:
Server 'rao', Procedure 'resume', Line 1:
Command <resume> failed - Desired state <REPLICATE>
could not be achieved. Current state: <REPLICATION
DOWN>

```

- 3 The `ra_status` command returns the state of the Replication Agent. It is good practice to verify that the Replication Agent remains in replication state, even after the resume command executes successfully.

To detect an error that occurred after replication start-up, execute:

```
ra_status
go
```

If the Replication Agent is in replicating state, `ra_status` returns:

```
State Action
-----
REPLICATING Ready to replicate data.
```

The Replication Agent returns REPLICATION DOWN state if an error occurs:

```
1> ra_status
2> go
State          Action
-----
REPLICATION DOWN Waiting for operator command.
```

- 4 Validate that both primary and replicate connections are active:

```
isql -Usa -P -SSAMPLE_RS
admin who
go
```

Note Be aware that:

- The DSI connection for the primary database connection is usually down because you are not replicating data back to the primary database.
 - The Replication Agent connection, if established for the replicate database connection, is usually down, because you are not replicating data from the replicate database.
-

Do not proceed until `admin who` returns similar status for threads to the following:

Spid	Name	State	Info
13	DSI EXEC	Awaiting Command	101(1) SAMPLE_RS_ERSSD.SAMPLE_RS_ERSSD
9	DSI	Awaiting Message	101 SAMPLE_RS_ERSSD.SAMPLE_RS_ERSSD
8	SQM	Awaiting Message	101:0 SAMPLE_RS_ERSSD.SAMPLE_RS_ERSSD
54	DSI EXEC	Awaiting Command	102(1) DCOServer.oratest2

```

53 DSI          Awaiting Message 102 DCOServer.oratest2
17 SQM          Awaiting Message 102:0 DCOServer.oratest2DSI
20 DSI EXEC    Suspended          103(1) NY.NYora92
21 DSI          Suspended          103 NY.NYora92
24 DIST        Awaiting Wakeup   103 NY.NYora92
25 SQT          Awaiting Wakeup   103:1 DIST NY.NYora92
23 SQM          Awaiting Message 103:1 NY.NYora92
22 SQM          Awaiting Message 103:0 NY.NYora92
62 REP AGENT   Awaiting Command NY.NYora92

```

Testing replication

After you finish setting up the replication system, you can test replication.

❖ Testing replication

- 1 Connect to the primary Oracle instance as a regular user, not the maintenance user. Make sure the regular user also exists in the replicate database.

- 2 Create a test table to replicate in the primary database:

```
create table T1( a int, b char(10));
```

- 3 Grant permissions to any new or existing object to be replicated in the primary database:

```
grant all on T1 to public;
```

- 4 Create a test table in the replicate database:

```
create table T1( a int, b char(10));
```

- 5 Grant permissions to any new or existing object to be replicated in the replicate database, so that the Replication Server maintenance user can update this table:

```
grant all on T1 to public;
```

- 6 Connect to the Replication Agent and run the following command to mark the table:

```
pdb_setreptable T1,mark
```

- 7 After the table is marked and the Replication Agent is in a replicating state, insert test data into the test table and commit it.

By default, the work performed by the maintenance user of the primary connection is not replicated. The user ID used to insert transactions cannot be the same as the maintenance user defined in the primary connection. See “Configuring Replication Server for replication from the primary database” on page 15.

Replication Agent applies only committed transactions to a replicate database. However, because Oracle expects a commit command to be issued, follow simple test commands with an explicit commit command:

```
insert into T1 values ( 42, 'foo' );
commit;
```

- 8 Use your preferred Oracle query tool to examine the replicate site for results and compare the contents of your test table from both the primary and replicate sites.

Resetting the primary Oracle database for replication

In a test environment, you may occasionally need to reset the replication environment. Instead of deleting and re-creating a new Replication Agent instance, use this procedure to facilitate resetting the environment.

❖ Resetting the primary database for replication

- 1 Protect your new environment from old log information by using the following command in the Replication Agent to archive all current *redo* log data:

```
pdb_xlog move_truncpt
```

- 2 To retain marking and log device information, re-initialize the Replication Agent using `pdb_xlog init` with the `force` option, which forces the Replication Agent repository to be refreshed instead of overwritten:

```
pdb_xlog init, force
```

Note If you prefer to delete and replace all the information in the Replication Agent repository, issue the `pdb_xlog remove, force` command followed by a normal `pdb_xlog init` command (without the `force` option).

- 3 Reset the locator stored in Replication Server:

```
isql -USAMPLE_RS_RSSD_prim -PSAMPLE_RS_RSSD_prim_ps
```

```
-SSAMPLE_RS_ERSSD -DSAMPLE_RS_ERSSD
```

```
rs_zeroltm NY, NYora92  
go
```

The following appears:

```
Locator has been reset to zero.  
(return status = 0)
```

Setting Up Replication for Microsoft SQL Server

This chapter identifies the components that are required to implement a Sybase replication system for Microsoft SQL Server, as well as an overview of the tasks and instructions for installing and configuring a sample replication environment for Microsoft SQL Server.

Topic	Page
Sybase replication system	35
Prerequisites	36
Installing replication components	37
Configuring replication components	48
Testing replication	69

Note Use the procedures in this chapter only for proof-of-concept (POC) or testing, not for production.

Sybase replication system

These components are required to implement a Sybase replication system for Microsoft SQL Server:

- A primary Microsoft SQL Server database
- A replicate Microsoft SQL Server database
- A Replication Server
- The Replication Server Options components:
 - Replication Agent
 - ECDA Option for ODBC

Figure 2-1 illustrates a Sybase replication system with Microsoft SQL Server databases. It shows the flow of data between the databases and the Replication Agent, Replication Server, and ECDA database gateway.

Figure 2-1: Sybase replication system for Microsoft SQL Server

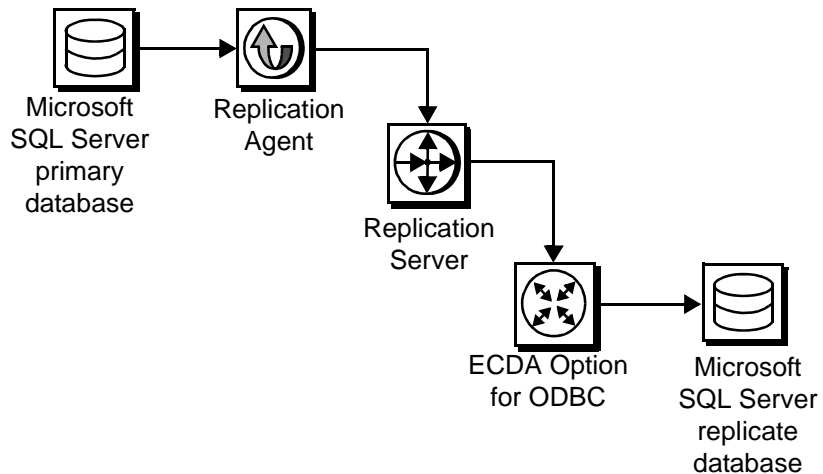

Prerequisites

Before you begin setting up the replication system, be familiar with the Microsoft SQL Server data server and have an understanding of Sybase replication. In addition:

- ECDA for ODBC must be installed on the same host as your replicate Microsoft SQL Server database.
- You have obtained the licenses for the Replication Server and Replication Server Options.
- Microsoft SQL Server 2005 SP2 and Microsoft SQL Server 2008, with database compatibility set to 2005(90), must be installed and configured to serve as the source (primary) database and as the target (replicate) database from which Replication Agent replicates transactions.
- Microsoft SQL Server JDBC driver 1.2 must be installed.
- TCP/IP connectivity must be available.

During this procedure:

- Because Replication Agent for Microsoft SQL Server is limited to the Microsoft Windows platform, all examples shown are for Windows.

Note On Windows Vista and Windows Server 2008, you must be logged in as an Administrator.

- Sybase recommends that you do not use Replication Server reserved words for object names and connection names. A complete list of reserved words is in the *Replication Server Reference Manual*.

System requirements

The target Windows computer on which you are installing the replication components must meet the following minimum memory and disk space requirements:

Table 2-1: Memory and disk requirements

Components	Memory (RAM)	Disk space
Replication Server	512MB	380MB
ECDA	512MB	440MB
Replication Agent	512MB	300MB

To improve performance by avoiding multiple network hops, Sybase recommends that Replication Server, ECDA for ODBC, and the target database reside on the same machine.

See *Replication Server Options 15.5 Release Bulletin*.

Installing replication components

Sybase recommends that you install all replication components on the same host where a Microsoft SQL Server has already been installed and is running with both the primary and replicate databases. This simplifies the quick-start process and avoids the step of separately installing a Microsoft SQL Server ODBC driver for ECDA Option for ODBC.

Identifying the Sybase installation directory

Replication Agent, Replication Server, and ECDA are installed in the same base directory, which is identified by the SYBASE environment variable. Select a path on a host drive to be the recipient of the Sybase installation and configuration activities.

Accessing products from the SPDC

If you are not using installation CDs, go to the Sybase Product Download Center (SPDC) Web site to obtain replication software.

❖ Downloading the replication software

Note This procedure requires you repeat steps to download two products: Replication Server and Replication Server Options.

You must have a login ID and password to download software from the SPDC.

- 1 Go to SPDC at <https://sybase.subscribenet.com/control/sybs/login> and enter your login ID and password.

The Product List page appears.

- 2 Select Replication Server.

The high-level Product Information page appears.

- 3 Select Replication Server again.

The detailed Product Information page appears.

- 4 Select the Replication Server software you need by primary database, version, and platform (return later to this detailed Product Information page to select Replication Server Options software).

The Software Terms and Conditions page appears, listing countries and regions.

- 5 Either:

- Select I Agree to accept the terms without reading them, go to the Product Download Page, and continue with step 6, or
- Select your country or region to read the terms.

The software licence agreement for the software appears. Read the terms and either:

- Select I Agree to accept the terms, go to the Product Download Page, and continue with step 6, or
 - Select Cancel to return to the high-level Product Information page.
- 6 The Product Download Page lists the software and documentation for the product. Select FTP Download or Advanced Download Options for the Replication Server software to download and save the compressed files to your local drive.

Note For each product, the documentation download contains installation-related documents, and the SyBooks download contains the rest of the documentation set.

- 7 Return to the detailed Product Information page that you accessed in step 3 and select the Replication Server Options software by primary database, version, and platform.

The Software Terms and Conditions page appears, listing countries and regions.

- 8 Navigate the Software Terms and Conditions pages as you did in step 5.
- 9 At the Product Download Page, select FTP Download or Advanced Download Options for the components of Replication Server Options to download, and save the compressed files to your local drive:
- Replication Agent 15.5
 - ECDA Options 15.0
 - DirectConnect™ Client 15.0
- 10 Uncompress and extract all the installation images to your local drive.
- 11 Download the ECDA 15.0 ESD #3:
- a Point your Web browser to the Sybase Support Page at <http://www.sybase.com/support>.
 - b Select EBFs/Maintenance. If prompted, enter your MySybase user name and password.
 - c Select EnterpriseConnect Data Access. A list of EBFs and maintenance releases appears.

- d Find the EBF containing the ECDA 15.0 ESD #3 for your platform, for example:

EBF *xxxxx*: 15.0 ESD #3

Here, *xxxxx* is the number of the EBF containing the ECDA 15.0 ESD #3 for your platform.

- e Click the Info icon to display the EBF/Maintenance report, and click the product description to download the software.

Installing Replication Agent

If Replication Agent is already installed, go to “Installing Replication Server” on page 42.

Install Replication Agent on a server where it can directly access the Microsoft SQL Server transaction logs.

Installing the Replication Agent creates a directory structure containing the Replication Agent binaries, scripts, JRE, and associated files. There are no configuration steps during installation.

❖ Installing Replication Agent software

- 1 Use one of the following methods to install the software.
 - After following the download instructions in “Accessing products from the SPDC” on page 38, go to the location where you extracted the Replication Agent 15.5 for Windows installation image, or
 - Insert the Replication Agent CD into your CD drive.

- 2 Execute the setup routine for Windows:

`setup`

- 3 If you see an error message saying that there is not enough temporary disk space, add the following to your `setup` command:

`setup -is:tempdir tempDirectory`

Here, *tempDirectory* is a directory with at least 100MB of disk space that the installation program can use.

- 4 On the Welcome window, click Next.
- 5 Select a geographic location that displays the license agreement. Select I Agree, and click Next.

- 6 Enter the directory where you want to install Replication Agent:
 - If the directory does not exist, the installation program prompts you to create it. Click Yes.
 - If the destination directory exists, you receive a warning message that you are installing into an existing directory. Click Next.
- 7 Select Typical for the installation setup type, and click Next.
- 8 On the Sybase Software Asset Management License Server window, use one of these options to enter the license:
 - Specify license keys – click Browse to select the license file.
Alternatively, copy and paste the license information directly in the license pane. Click Next to proceed.
 - Use previously deployed license server – if you have a previously deployed license server, enter the host name of the machine where the license server is running, and the port number if the port number you are using is not default. Click Next.
 - Continue installation without a license key – if you do not have a license, you can select this option, and click Next to proceed. The installer allows you to install and use Replication Agent without a license for a grace period of 30 days. To continue using Replication Agent after the end of the grace period, obtain valid license from the SPDC, and install it.

For more information on SySAM licensing, see the *Sybase Software Asset Management Users Guide*.
- 9 The SySAM notification window prompts you to configure your server for e-mail notification. When configuration is enabled, you receive information about license management events that require attention. At the SySAM notification window, do one of the following:
 - Select Yes and either accept the default values that are supplied, or enter values for the following:
 - SMTP server host name
 - SMTP server port number
 - Sender e-mail address
 - Recipient e-mail address

- Message severity level of an event that triggers an e-mail message. Your choices are:
 - Informational
 - Warning
 - Error
- If you choose not to have e-mail alerts or severity messages logged, select No.

Click Next.

- 10 The installation program displays a summary of what is to be installed. Click Install.
- 11 The installation program starts to install Replication Agent, displaying the progress status. Click No to All if you see the following message:

```
There are newer files already installed and do you
want to replace them?
```
- 12 When you receive a message indicating that Replication Agent was successfully installed, click Done.

See the *Replication Agent Installation Guide*.

❖ Verifying the installation

- 1 In a command window, change to the directory where you installed Replication Agent.
- 2 Change to `%SYBASE%\RAX-15_5\bin`.
- 3 Obtain the Replication Agent version string:

```
ra -v
```

If the Replication Agent installation completed successfully, you see the Sybase copyright and the Replication Agent version string.

Installing Replication Server

If Replication Server is already installed, go to “Installing ECDA Option for ODBC” on page 46.

While installing Replication Server:

- Allocate a disk partition of at least 20MB for each Replication Server you are installing. You can add more partitions later, if necessary. Check each partition to make sure it is available and has write permissions.

Allocate the entire partition to the Replication Server. If you allocate only a portion of the partition to Replication Server, you cannot use the remainder for any other purpose.

❖ **Installing Replication Server**

- 1 Use one of the following methods to download Replication Server software.
 - After following the download instructions in “Accessing products from the SPDC” on page 38, go to the location where you extracted the Replication Server 15.5 for Windows installation image, or
 - Insert the Replication Server CD in your CD drive.

- 2 Execute the setup routine (GUI mode):

```
setup
```

- 3 If you see an error message saying that there is not enough temporary disk space, add the following to your setup command:

```
setup -is:tempdir tempDirectory
```

Here, *tempDirectory* is a directory with at least 100MB of disk space that the installation program can use.

- 4 On the Welcome window, click Next.
- 5 Select a geographic location that displays the license agreement. Select I Agree, and click Next.
- 6 Enter the directory where you want to install Replication Server:
 - If the directory does not exist, the installation program prompts you to create it. Click Yes.
 - If the destination directory exists, you receive a warning message that you are installing into an existing directory. Click Yes.
- 7 Select Typical for the installation setup type, and click Next.
- 8 The installation program displays a summary of what is to be installed. Click Next.
- 9 The installation program starts to install Replication Server, displaying the progress status. You may see the following message:

There are newer files already installed and do you want to replace them?

Click No to All.

- 10 When you receive a message indicating that Replication Server software has successfully installed, click Next.

Note This procedure uses the SAMPLE_RS Replication Server.

- 11 The SySAM License Server window opens and displays this prompt:

Will licenses be obtained from the License Server?

Respond based on how you set up your environment and use the license obtained from the Software Product Download Center (SPDC) Web site for Replication Server.

Click Next.

- 12 The SySAM notification window prompts you to configure your server for e-mail notification. When configuration is enabled, you receive information about license management events that require attention. Select Yes, and either accept the default values that are supplied, or enter values for the following:

- SMTP server host name
- SMTP server port number
- Sender e-mail address
- Recipient e-mail address
- Message severity level of an event that triggers an e-mail message. Your choices are:
 - Informational
 - Warning
 - Error

If you choose not to have e-mail alerts or severity messages logged, select No.

Click Next.

- 13 To start a sample Replication Server, select Yes, and click Next.
- 14 This information appears and should be recorded:

This page contains detailed information regarding the sample Replication Server. Please record this information.

The sample Replication Server will be called `SAMPLE_RS` and will run on port 11752. It will be configured with a user of `sa` and no password.

The sample Replication Server will use an embedded RSSD called `SAMPLE_RS_ERSSD` that runs on port 11751. It will be configured with a user of `SAMPLE_RS_RSSD_prim` and a password of `SAMPLE_RS_RSSD_prim_ps`.

The installer has updated the appropriate interfaces file or `sql.ini` file.

All files and logs associated with the sample Replication Server will be located in the directory `<samp_repserver>`.

The sample Replication Server will be configured using the file `<SAMPLE_RS.res>`.

Here, `<samp_repserver>` and `<SAMPLE_RS.res>` are paths to the sample Replication Server and sample Replication Server configuration file, respectively.

Click Next.

- 15 When the sample Replication Server is running and an “Installation was successful” message appears, click Finish.

❖ Verifying the installation

- 1 In a command window, change to the directory where you installed Replication Server.
- 2 Log in to Replication Server:

```
isql -Usa -P -SSAMPLE_RS
```
- 3 Verify the Replication Server version:

```
admin version
go
```
- 4 Exit the `isql` session with the `quit` command.

Installing ECDA Option for ODBC

If ECDA Option for ODBC is already installed, go to “Configuring replication components” on page 48.

When installing ECDA for ODBC, install ECDA on the same server as the replicate database. This eliminates a network hop and improves performance.

❖ Installing ECDA for ODBC in GUI mode

Note To install using the console mode or a response file, see the *ECDA Installation Guide* for Microsoft Windows.

1 Use one of the following methods to install the software:

- After following the download instructions in “Accessing products from the SPDC” on page 38, go to the location where you extracted the ECDA Option for ODBC 15.0 installation image.
- Insert the ECDA 15.0 Option for ODBC for Window CD into your CD drive.

2 Execute the setup routine:

```
setup
```

3 If you see an error message saying that there is not enough temporary disk space, add the following to your setup command:

```
setup -is:tempdir tempDirectory
```

Here, *tempDirectory* is a directory with at least 100MB of disk space that the installation program can use.

4 On the Welcome window, click Next.

5 Select a geographic location that displays the license agreement. Select I Agree, and click Next.

6 Enter the directory where you want to install ECDA:

- In the destination directory, enter the base directory identified by the SYBASE environment variable. Click Yes to install over an existing directory.
- If the destination directory exists, you receive a warning message that you are installing into an existing directory. Click Yes.

7 Select Custom setup, and click Next.

8 Unselect ECDA Option for Oracle, and click Next.

9 Verify the modules to install. Click Next.

You may receive this message:

```
There are newer files already installed and do you
want to replace them
```

Click No to All.

10 When you receive a message that the installation was successful, click Next.

11 The SySAM License Server window opens and displays this prompt:

```
Will licenses be obtained from the License Server?
```

Respond based on how you set up your environment and use the license obtained from the Software Product Download Center (SPDC) Web site for Replication Server Options.

Click Next.

12 The SySAM notification window prompts you to configure your server for e-mail notification. When configuration is enabled, you receive information about license management events that require attention. Select Yes and either accept the default values that are supplied, or enter values for the following:

- SMTP server host name
- SMTP server port number
- Sender e-mail address
- Recipient e-mail address
- Message severity level of an event that triggers an e-mail message. Your choices are:
 - Informational
 - Warning
 - Error

If you choose not to have e-mail alerts or severity messages logged, select No. Click Next.

13 When you receive a message indicating that ECDA was successfully installed, click Finish.

ECDA for ODBC, including the DirectConnect server, is now installed.

- 14 Apply the ECDA 15.0 ESD #3:
 - a Extract the zip file for the ECDA 15.0 ESD #3 that you downloaded in “Downloading the replication software” on page 38.
 - b Go to the directory into which you extracted the zip file.
 - c Install the ECDA 15.0 ESD #3 in the same way that you installed ECDA earlier in this procedure.

Configuring replication components

This section describes the tasks you must perform to configure each of the components in the replication system.

Configuring ECDA Option for ODBC

Configuring the ECDA Option for ODBC involves:

- 1 Configuring the Microsoft SQL Server ODBC driver
- 2 Configuring and starting the DirectConnect server
- 3 Creating a maintenance user for replication

Configuring the Microsoft SQL Server ODBC driver

If you already have a data source configured for your replicate database, skip to “Configuring and starting the DirectConnect server” on page 49.

When you installed Microsoft SQL Server, an ODBC driver was also installed. Configure this driver to connect to the replicate database.

❖ **Configuring the Microsoft SQL Server ODBC driver**

- 1 Open the ODBC Driver Manager by navigating to Control Panel | Administrative Tools and double-clicking the Data Sources (ODBC) icon.
- 2 Click the Drivers tab, and verify that the Microsoft SQL Server driver is version 2000.86.1830.00. If it is an earlier version, go to the Microsoft Web site to download and install the correct version.

- 3 Click the System DSN tab, click Add, and select the Microsoft SQL Server driver. Click Finish.
- 4 In the Name field, enter a name that identifies your replicate data server and database, for example, `my_mssql_datasource_name`. Use this name later when you configure the ECDA access service. Select the replicate Microsoft SQL Server in the Server drop-down list. Click Next.
- 5 Be sure that Microsoft SQL Server authentication is selected, and the Connect to Microsoft SQL Server check box is checked. Enter a valid Microsoft SQL Server login ID and password, and click Next.
- 6 Select Change the Default Database To, and select the replicate database from the drop-down list. Click Next.
- 7 Click Finish.
- 8 Verify ODBC connectivity to the replicate database by clicking Test Data Source. If connectivity is not successful, verify that you have configured the ODBC driver correctly.
- 9 Click OK.
- 10 You should now see your Microsoft SQL Server data source in the list of System Data Sources. Click OK.

Configuring and starting the DirectConnect server

Before you begin to create and configure the DirectConnect server, make sure that:

- The name for a valid Microsoft SQL Server account is available. This name is used as the administrator for the DirectConnect server.
- The number of the unused port to be used by the DirectConnect server is available.

❖ **Creating and configuring a DirectConnect server**

- 1 Start the Create Server wizard by navigating to the `%SYBASE%\DC-15_0\DCWizard` directory and executing the `DCWizard` script. The Welcome Create Server wizard appears. Click Next.
- 2 Select ECDA Option for ODBC. Click Next.
- 3 Enter the server name for the new DirectConnect server and the port number that you want the server to listen on. Click Next.

- 4 Enter the ECDA access service name that you want to use for the replicate Microsoft SQL Server database, for example, `my_mssql_access_service`. Click Next.
- 5 Verify the DirectConnect server information. If correct, select Create Server. Otherwise, click Back to return to the previous window and provide the correct information.
- 6 Open the `%SYBASE%\DC-15_0\servers\servername\cfg\dcany.cfg` file, where *servername* is the name of the server you created using the DCWizard.
- 7 In the file, locate the name of the Microsoft SQL Server access service that you created in step 4 using the DCWizard. Under that, set the `ConnectionSpec1` parameter to the name of the Microsoft SQL Server ODBC data source you created. For example:

```
[Service Library]
{Client Interaction}
SvcLibDescription=Access Service Library for ODBC
{Logging}
LogSvcLibStatistics=0
[my_mssql_access_service] {ACS Required}
ConnectionSpec1=my_mssql_datasource_name
{Client Interaction}
EnableAtStartup=yes
TransactionMode=long
```

Note `TransactionMode=long` indicates that the client session will manually issue the commit command for transactions.

- 8 Start the DirectConnect server:
 - a Open a command window, and navigate to the DirectConnect installation directory. For example:

```
cd c:\sybase\DC-15_0
```
 - b Execute the `DC_SYBASE.bat` script to set the DirectConnect environment variables.
 - c Navigate to the DirectConnect *bin* directory:

```
cd bin
```
 - d Start the DirectConnect server. This also starts all of the configured access services:

```
DCStart -Sservername
```

Here, *servername* is the name of the DirectConnect server.

9 Click Finish.

❖ **Verifying that you can connect to Microsoft SQL Server**

1 Open a command window in the *%SYBASE%* directory of your ECDA installation.

2 Change to the *%SYBASE%\DC-15_0* directory.

3 Set the environment variables by sourcing the *%SYBASE%\DC_SYBASE.bat* file.

4 Log in to Microsoft SQL Server through the DirectConnect service:

```
isql -Uvaliduser -Ppassword -
my_mssql_access_service
```

Here, *validuser* and *password* are any valid user and password, and *my_mssql_access_service* is the DirectConnect service name.

5 Verify the connection to the replicate Microsoft SQL Server database by obtaining the DBMS name and version number:

```
select @@sqldbmsname
go
```

```
SQLDbmsName
-----
Microsoft SQL Server
```

```
select @@sqldbmsver
go
```

```
SQLDbmsVer
-----
09.00.1399
```

6 Exit the *isql* session with the *quit* command.

Creating a maintenance user for replication

The maintenance user is a valid Microsoft SQL Server user that the Replication Server uses to apply commands to the replicate Microsoft SQL Server database. Replication Server requires one maintenance user to be defined for each connection.

❖ Creating a maintenance user in Microsoft SQL Server

- 1 Connect to the replicate database, and enter the following command to create the maintenance user login:

```
CREATE LOGIN maintuser WITH PASSWORD='password',  
DEFAULT_DATABASE=replicate_db_name;
```

Here, *password* is the maintenance user login password, and *replicate_db_name* is the replicate database name.

- 2 At the replicate database, enter the following command to create a maintenance user:

```
CREATE USER maintuser FOR LOGIN maintuser;
```

- 3 Grant database owner permission to the maintenance user:

```
EXEC sp_addrolemember 'db_owner', 'maintuser';
```

Configuring Replication Server

Configuring Replication Server includes the following tasks:

- Configuring Replication Server for replication to the target database
- Configuring Replication Server for replication from the primary database

Configuring Replication Server for replication to the target database

❖ Creating a Replication Server connection

- 1 Navigate to the `%SYBASE%\RAX-15_5\scripts\mssql` directory.
- 2 Make a copy of the `mssql_create_rs_standby_connection.sql` script named `my_mssql_create_rs_standby_connection.sql`.
- 3 Before executing the `my_mssql_create_rs_standby_connection.sql` script against your Replication Server, change the `{rds}.``{rdb}` to the name of the connection that Replication Server uses to connect to the DirectConnect access service, where:

- *rds* is the DirectConnect access service name.
- *rdb* is any valid identifier. Sybase recommends that you use the Microsoft SQL Server replicate database name.
- *maintuser* and *password* are the maintenance user and password created in ECDA Option for ODBC in step 1 of “Creating a maintenance user for replication” on page 52. For example:

```
create connection to rds.rdb
using profile rs_msss_to_msss;standard
set username maintuser
set password "password"
go
```

Note In the previous example, password is a Replication Server reserved word and therefore, must be enclosed in double quotes.

- 4 Create the connection to the replicate database:

```
isql -Usa -P -SSAMPLE_RS -i my_mssql_create_rs_standby_connection.sql
```

- 5 Log in to SAMPLE_RS and verify the Replication Server connection to the replicate database:

```
isql -Usa -P -SSAMPLE_RS
admin who
go
```

You should see a message returned for the DSI connection *msss_dco.dbname*. Verify that the status is “Awaiting Message” or “Awaiting Command.”

- 6 Exit the isql session with the quit command.

Configuring Replication Server for replication from the primary database

This section describes the configuration steps required for replication from the primary database. It includes:

- Creating a Replication Server connection to the primary database
 - Creating a database replication definition
 - Creating a database replication subscription
- ❖ **Creating a Replication Server connection to the primary database**

- 1 Go to the %SYBASE%\RAX-15_5\scripts\sybase directory.

- 2 Make a copy of the `rs_create_test_primary_connection.sql` script named `my_mssql_rs_create_primary_connection.sql`.
- 3 Before executing the `my_mssql_rs_create_primary_connection.sql` script against your Replication Server, change `{rax.test}` to the name of the connection between Replication Agent and Replication Server, where:
 - `rax` is the name of the Microsoft SQL Server data server.
 - `test` is the name of the Microsoft SQL Server database.

For example, `NY.NYmss5`.

Note Save these values to be used later for the `rs_source_ds` and `rs_source_db` parameters in the Replication Agent `mssql.rs` file.

- 4 Execute the script in Replication Server:

```
isql -Usa -P -SSAMPLE_RS -i my_mssql_rs_create_primary_connection.sql
```

A message appears that indicates the Replication Server connection to the primary database has been created.

❖ Creating a database replication definition

- 1 Navigate to the `%SYBASE%\RAX_15-5\scripts\sybase` directory.
- 2 Make a copy of the `rs_create_test_db_repdef.sql` script named `my_mssql_rs_create_test_db_repdef.sql`.
- 3 Before executing the `my_mssql_rs_create_test_db_repdef.sql` script, change the value of `{pds}.{pdb}` to the name of the connection string you defined for the primary database, where:
 - `pds` is the name of the Microsoft SQL Server data server.
 - `pdb` is the name of the Microsoft SQL Server database.

For example, `NY.NYmss5`.

Note Save these values to be used later for the `rs_source_ds` and `rs_source_db` parameters in the Replication Agent `mssql.rs` file.

This is a database replication definition example:

```
create database replication definition NY_repdef1
with primary at NY.NYmss5
go
```

- 4 Connect to the Replication Server and enter:

```
isql -Usa -P -SSAMPLE_RS -i my_mssql_rs_create_test_db_repdef.sql
```

A message appears that indicates the database replication definition has been created.

❖ Creating a database replication subscription

- 1 Make a copy of the *rs_create_test_db_sub.sql* script named *my_mssql_rs_create_test_db_sub.sql*.
- 2 Before executing the *my_mssql_rs_create_test_db_sub.sql* script, change *{pds}.{pdb}* and *{rds}.{rdb}* to the appropriate connection name, where:
 - *pds* is the name of the Microsoft SQL Server data server.
 - *pdb* is the name of the Microsoft SQL Server database.
 - *rds* is the DirectConnect access service name.
 - *rdb* is the name of the replicate database.

Note Save these values to be used later in the Replication Agent *mssql.rs* file.

Here is an example of create database replication subscription:

```
create subscription NY_sub1
for database replication definition NY_repdef1
with primary at NY.NYmss5
with replicate at my_mssql_access_service.my_repl_db
without materialization
go
```

- 3 Connect to Replication Server and execute:

```
isql -Usa -P -SSAMPLE_RS -i my_mssql_rs_create_test_db_sub.sql
```

A message appears that indicates the subscription is being created.

Configuring Replication Agent

Configuring Replication Agent involves:

- 1 Configuring and verifying the primary Microsoft SQL Server
- 2 Configuring and validating the Replication Agent resource file

- 3 First-time initialization
- 4 Subsequent initialization
- 5 Verifying the Replication Agent replicating state

On Windows Vista, you must be logged in as an Administrator.

Configuring and verifying the primary Microsoft SQL Server

Before you configure Replication Agent and configure the primary Microsoft SQL Server database for replication, complete these procedures:

- Verify the compatibility level of Microsoft SQL Server.
- Disable Microsoft SQL Server replication.
- Create a Microsoft SQL Server user and grant Microsoft SQL Server permissions.
- Enable remote DAC.
- Obtain the Microsoft SQL Server DAC port number.
- Verify the supplemental logging of primary key data.
- Make the primary transaction log files readable for Replication Agent.
- Stop the Analysis Service.
- Enable TCP/IP.

❖ Verifying the compatibility level of Microsoft SQL Server

Replication Agent supports Microsoft SQL Server 2005 Service Pack 2 and Microsoft SQL Server 2008. Verify that the database compatibility level is set to Microsoft SQL Server 2005 (90) or Microsoft SQL Server 2008 (100):

- 1 In the Microsoft SQL Server Management Studio, right-click your primary database and select Properties.
- 2 In Database Properties, click Options, and verify that the Compatibility level is “Microsoft SQL Server 2005 (90) or Microsoft SQL Server 2008 (100).” If it is not, select that compatibility from the drop-down list, and click OK.

❖ Disabling Microsoft SQL Server replication

- A Microsoft SQL Server publication cannot be created in the primary database used by Replication Agent for Microsoft SQL Server, and you cannot simultaneously use Microsoft replication and Replication Agent on the same Microsoft SQL Server database. If a Microsoft SQL Server publication already exists, remove the publication before using Replication Agent for Microsoft SQL Server.

❖ Creating a Microsoft SQL Server user and granting permissions

- Log in to the primary Microsoft SQL Server as a system administrator, and run the following commands to create a Microsoft SQL Server user named “ra_user” with the password “sybase,” and grant permissions to the user:

```
use master;  
create login ra_user;  
use <primary_database>;  
create user ra_user for login ra_user;  
EXEC sp_addsrvrolemember 'ra_user', 'sysadmin';
```

❖ Enabling remote DAC

- 1 From the Windows Start menu, choose Microsoft SQL Server | Configuration Tools | Surface Area Configuration | Surface Area Configuration for Features.
- 2 In the Surface Area Configuration for Features window, choose DAC under the MSSQLSERVER/Database Engine tree, and make sure the Enable Remote DAC check box is selected.

❖ Obtaining the Microsoft SQL Server DAC port number

- 1 Open the *ERRORLOG* file in a text editor. This file is located in the *log* directory of your Microsoft SQL Server. For example:

```
C:\Program Files\Microsoft SQL Server\MSSQL.1\MSSQL\LOG\ERRORLOG
```

- 2 Search for the string “Dedicated admin” to find an entry similar to the following:

```
2007-11-09 13:40:02.40 Server Dedicated admin  
connection support was established for listening  
locally on port 1348.
```

- 3 Record the port number specified in this entry for use in a later step.

❖ Verifying the version of the Microsoft Filter Manager Library

To make the primary transaction log files readable for Replication Agent, the Microsoft Filter Manager Library must be version 5.1.2600.2978 or later.

- 1 To determine the version of the library, in Windows Explorer, right-click *c:\windows\system32\ftlib.dll*, select Properties, and click the Version tab in the Properties dialog box.
- 2 If the version is earlier than 5.1.2600.2978, go to the Microsoft Web site at <http://windowsupdate.microsoft.com>, and update your Windows system.

❖ **Making the primary transaction log files readable for Replication Agent**

Install and set up the *sybfilter* driver so that Replication Agent can read the primary transaction log files.

- 1 In Windows Explorer, navigate to the *sybfilter* driver installation directory. This directory is located at *%SYBASE%\RAX-15_5\system\<platform>*, where *<platform>* is *winx86*, *winx64*, or *winvistax64*.
- 2 Right-click the *sybfilter.inf* file to install the *sybfilter* driver.

The *sybfilter* drivers that you must install are:

- *winvistax64* for Windows Server Vista x64 and Windows Server 2008 R1 x64
- *winx64* for Windows Server XP Professional x64 and Windows Server 2003 x64.
- *winx86* for Windows Server XP Professional x86, Windows Server 2003 x86, Windows Server Vista x86, and Windows Server 2008 R1 x86.

Note There can be only one installation of the *sybfilter* driver on a Windows machine. After the driver is installed, it works for all Replication Agent for Microsoft SQL Server instances running on the same machine.

- 3 Under any directory, create a configuration file to store all log file paths for primary databases. The configuration file must have a *.cfg* suffix. For example, under the directory *%SYBASE%\RAX-15_5\system\<platform>*, create a file named *LogPath.cfg*.
- 4 Add a system environment variable named *RACFGFilePath*, and set its value to the path of the configuration file.
 - a Open the Control Panel, click System, click the Advanced tab, and choose Environment Variables.
 - b Click New to add a new system variable.
 - c Name the variable *RACFGFilePath*, and set its value to the location of your configuration file.

- 5 In Windows Explorer, navigate to %SYBASE%\RAX-15_5\bin, and double-click the *sybfiltermgr.exe* file to start the *sybfilter* driver management console.
- 6 To start the *sybfilter* driver, enter start at the management console.
- 7 Add the log file path to the *sybfilter* driver with the user manager or by modifying the configuration file:

- User manager – use the add command in the management console. The syntax for this command is as follows:

```
add serverName dbName logFilePath
```

For example, to add the log file named *pdb2_log.ldf* at *C:\Program Files\Microsoft SQL Server\MSSQL.1\MSSQL\Data* to the *dbName* database on the *serverName* data server, use the following:

```
add myserverName dbName C:\Program Files\Microsoft SQL
Server\MSSQL.1\MSSQL\Data\pdb2_log.ldf
```

Note If you add the log file path with the user manager, the user manager refreshes all log paths in the *sybfilter* driver automatically after adding the log path into the configuration file.

- Configuration file – to add the log file path directly to the configuration file, open and manually edit the configuration file. This an example of log file path entries:

```
[myserver, pdb1]
log_file_path=C:\Program Files\Microsoft SQL
Server\MSSQL.1\MSSQL\Data\pdb11_log.ldf
log_file_path=C:\Program Files\Microsoft SQL
Server\MSSQL.1\MSSQL\Data\pdb12_log.ldf
[myserver, pdb2]
log_file_path=C:\Program Files\Microsoft SQL
Server\MSSQL.1\MSSQL\Data\pdb2_log.ldf
```

Note After you have added the log file paths to the configuration file, use the refresh command in the management console.

- 8 If you added a log file for your primary database before adding the log file path to the *sybfilter* driver, restart Microsoft SQL Server to make the log file readable.

- 9 At the management console, verify that log files are readable. If some log files are unreadable, make sure the files have been created and that Microsoft SQL Server has been restarted, if necessary.

See the *Replication Agent Primary Database Guide*.

❖ **Stopping the Analysis Service**

- 1 From the Windows Control Panel, select Administrative Tools | Services.
- 2 In the listed services, find the service named Microsoft SQL Server Analysis Service (*SERVER*), where *SERVER* is the name of your Microsoft SQL Server data server.
- 3 Stop this service.

❖ **Enabling TCP/IP**

- 1 From the Windows Start menu, choose Microsoft SQL Server | Surface Area Configuration | Surface Area Configuration for Services and Connections.
- 2 Under the Database Engine tree, click Remote Connections.
- 3 Select “Local and remote connections,” and “Using both TCP/IP and Named Pipes protocols.”

❖ **Installing the Microsoft SQL Server JDBC driver**

- 1 Go to the Microsoft download site (<http://www.microsoft.com/downloads>) and search for the following string:

```
Microsoft SQL Server 2005 JDBC driver
```
- 2 Click the link for the 1.2 driver, and follow the instructions to download and install the driver.
- 3 Open Control Panel | System, click the Advanced tab, and click Environment Variables.
- 4 In the System Variables window, if the CLASSPATH variable is not listed, click New. Otherwise, select it, and click Edit.
- 5 Enter the full path of the JDBC driver, using a semicolon (;) to separate it from any other drivers.
- 6 Click OK three times.

Configuring and validating the Replication Agent resource file

A single installation of the Replication Agent can support replication from multiple databases. However, one Replication Agent instance is needed for each Microsoft SQL Server database that is to be replicated.

❖ Configuring and validating the Replication Agent parameters in a resource file

- 1 Locate the resource file template.

The majority of configuration values required to create and initialize a Replication Agent can be recorded and stored in a resource file. Using a resource file provides a means to record or retain the configuration information for a Replication Agent instance, allowing an instance to be removed and re-created.

The Microsoft SQL Server resource file template is at `%SYBASE%\RAX-15_5\init\mssql.rs`.

- 2 Create an instance resource file:

Copy the resource file template `%SYBASE%\RAX-15_5\init\mssql.rs` to another file, for example, `myra.rs`.

Change the values assigned to properties in the resource file so they match the values required for your environment. The majority of these values are host, port, user, and password information for the Microsoft SQL Server, Replication Server, and RSSD connections.

- Set the value of `rs_source_ds` to the value you chose for `rax` and `pds` in previous procedures.
- Set the value of `rs_source_db` to the value you chose for `test` and `pdb` in previous procedures.

The resource file is self-documenting, with each parameter described. See the *Replication Agent Administration Guide*.

Warning! The combined values of `rs_source_ds` and `rs_source_db` must match the `{pds.pdb}` values of the Replication Server primary connection name.

Table 2-2: Resource file parameters

Parameter	Description	Example values
instance name	Any valid name.	myra

Parameter	Description	Example values
admin_port	Port number that Replication Agent uses.	20500 (if in use, select a different port number)
pds_server_name	Name of the primary Microsoft SQL Server.	TEAMSTER
pds_port_number	Port number for the primary Microsoft SQL Server.	1433
pds_dac_port_number	Microsoft SQL Server Dedicated Administration connection port number.	1348
pds_database_name	Name of the primary database.	test_db
pds_username	User ID that Replication Agent uses to access the primary data server.	ra_user
pds_password	Password for pds_username.	sybase
rs_host_name	Machine where Replication Server is installed.	teamster
rs_port_number	Port where Replication Server is installed.	11752
rs_username	Replication Server user with CONNECT SOURCE and CREATE OBJECT capabilities.	SAMPLE_RS_ra
rs_password	Password for rs_username.	SAMPLE_RS_ra_ps
rs_source_ds	Valid name representing data server of primary Microsoft SQL Server database.	NY
rs_source_db	Valid name representing primary Microsoft SQL Server database.	NYmss5
rs_charset	Character set that Replication Server is using. Note The value defined for the rs_charset configuration parameter must match the RS_charset value in the Replication Server configuration file. <i>%SYBASE%\REP-15_5\install\<server>.cfg.</i>	cp850
rssd_host_name	Machine where RSSD resides.	teamster
rssd_port_number	Port number where RSSD resides.	11751
rssd_database_name	Database name for RSSD.	SAMPLE_RS_ERSSD
rssd_username	Valid user for RSSD.	SAMPLE_RS_RSSD_maint
rssd_password	Password for rssd_username.	SAMPLE_RS_RSSD_maint_ps
start_instance	Automatically start the instance that was created.	yes
initialize_instance	Automatically initialize the new Replication Agent instance.	yes

- 3 Be sure your CLASSPATH environment variable points to the Microsoft SQL Server JDBC driver, and use the Replication Agent `ra_admin` utility to validate the settings in the new instance resource file using the `-vr` parameter. For example:

```
%SYBASE%\RAX-15_5\bin\ra_admin -vr myra.rs
```

Validation results are returned as one of the following:

- Response-file processing completed
- Response-file processing completed with errors

If any validation fails, the `ra_admin` utility returns an error message and information about the failure. You can repeat the validation process as many times as necessary until it executes without error. No entities are changed or created.

First-time initialization

To initialize the primary data server, Replication Agent for Microsoft SQL Server installs objects at the data-server level and at the database level. Data-server level modifications are required only once. Use this procedure if you are initializing the primary data server and a Replication Agent instance for the first time.

If you have previously initialized the primary data server and a Replication Agent instance and want to initialize another Replication Agent instance, skip to “Subsequent initialization” on page 66.

❖ Configuring the primary data server and a Replication Agent instance for the first time

- 1 Stop the Microsoft SQL Server service.
 - a In Control Panel | Administrative Tools | Services, find the service named Microsoft SQL Server (*SERVER*), where *SERVER* is the name of your Microsoft SQL Server data server. For example:

```
Microsoft SQL Server (TEAMSTER)
```

- b Stop the service.
- 2 Open a command window, and restart Microsoft SQL Server in single-user mode:

```
"C:\Program Files\Microsoft SQL
Server\MSSQL.1\MSSQL\Binn\sqlservr.exe" -m -s
instanceName
```

Here, *instanceName* is the name of the Microsoft SQL Server instance.

- 3 Execute the resource file to create the Replication Agent instance. In your resource file, if you set `start_instance` to `yes`, this step also starts the Replication Agent instance. In your resource file, if you also configured `initialize_instance` to `yes`, this step also initializes the Microsoft SQL Server and the Replication Agent instance.

After the resource file has been validated, use the `ra_admin` utility to create the Replication Agent instance using the `-r` parameter. For example:

```
%SYBASE%\RAX-15_5\bin\ra_admin -r myra.rs
```

Execution results are returned as one of the following:

- Response-file processing completed
- Response-file processing completed with errors

See the *Replication Agent Administration Guide*.

- 4 If your resource file set `start_instance` to `no`, change to the *SYBASE* directory and start the Replication Agent instance:

```
cd %SYBASE%\RAX-15_5\myra
```

Execute the *RUN* file, for example:

```
RUN_myra
```

- 5 Use the `dsedit` utility to update the Replication Server *sql.ini* file with the Replication Agent location, and verify the connection to the Replication Agent:

- a Open a command window in the *SYBASE* directory of your Replication Agent installation.
- b Set the environment variables by executing the *SYBASE.bat* file.
- c Log in to Replication Agent:

```
isql -Usa -P -Smyra
```

Here, *myra* is the name of Replication Agent.

- 6 If your resource file has `initialize_instance` set to `no`, initialize the primary data server and the Replication Agent instance:

- a Open a command window, and log in to the Replication Agent instance.
- b Issue the following command to create server xlog objects:

```
server_xlog init
```

- c Issue the following command to shutdown Replication Agent:

```
shutdown
```

- 7 Stop the Microsoft SQL Server in single-user mode:

- a Log in to the server:

```
"C:\Program Files\Microsoft SQL  
Server\90\Tools\Binn\SQLCMD.EXE" -U username -P  
password -S serverName
```

Here, *username*, *password*, and *serverName* are your user ID, password, and Microsoft SQL Server name.

- b Issue the shutdown command.

- 8 Restart Microsoft SQL Server in multiuser mode (normal start):

- a In Control Panel | Administrative Tools | Services, find the service named Microsoft SQL Server (*SERVER*) where *SERVER* is the name of your Microsoft SQL Server data server. For example:

```
Microsoft SQL Server (TEAMSTER)
```

- b Start the service.

- 9 Restart Replication Agent.

- a Change to the SYBASE directory and start the Replication Agent instance:

```
cd %SYBASE%\RAX-15_5\myra
```

- b Execute the RUN file, for example:

```
Run_myra
```

- 10 Initialize Replication Agent.

- a Log in to Replication Agent using isql:

```
isql -Usa -P -Smyra
```

where, *myra* is the name of Replication Agent.

- b Issue the following command:

```
pdb_xlog init
```

The Replication Agent instance is now running, and the primary data server and the Replication Agent instance have been initialized. Continue with “Verifying the Replication Agent replicating state” on page 67.

Subsequent initialization

Use the following procedure only if you have already initialized the primary data server, as described in “First-time initialization” on page 63, and you want to create another Replication Agent instance. This procedure creates and initializes only the Replication Agent instance, not the primary data server.

❖ Creating and initializing a Replication Agent instance

1 Execute the resource file to create the Replication Agent instance.

- After the resource file has been validated as described in “Configuring and validating the Replication Agent resource file” on page 61, use the `ra_admin` utility to create the Replication Agent instance using the `-r` parameter, for example:

```
%SYBASE%\RAX-15_5\bin\ra_admin -r myra.rs
```

Execution results are returned as one of the following:

- Response-file processing completed
- Response-file processing completed with errors

See the *Replication Agent Administration Guide*.

2 If your resource file has `initialize_instance` set to `no`, start the Replication Agent instance.

- a Change to the directory containing your Replication Agent instance *RUN* file, for example:
- b To start the Replication Agent instance, execute the *RUN* file, for example:

```
RUN_myra
```

3 Use the `dsedit` utility to update the Replication Server *sql.ini* file with the Replication Agent location, and verify the connection to the Replication Agent.

- a Open a command window in the *SYBASE* directory of your Replication Agent installation.
- b Set the environment variables by executing the *SYBASE.bat* file.
- c Log in to Replication Agent:

```
isql -Usa -P -Smyra
```

Here, *myra* is the name of Replication Agent.

- 4 If your resource file has `initialize_instance` set to `no`, open a new command window, log in to the Replication Agent instance, and initialize the Replication Agent instance and the primary Microsoft SQL Server database using the following Replication Agent command:

```
pdb_xlog init
```

Your Replication Agent instance is now running and has been initialized. Continue with “Verifying the Replication Agent replicating state” on page 67.

Verifying the Replication Agent replicating state

❖ Verifying the Replication Agent replicating state

- 1 Enter:

```
resume
go
```

If the Replication Agent successfully transfers to a replicating state, the following result is returned:

```
State Action
-----
REPLICATING Ready to replicate data.
```

The Replication Agent returns REPLICATION DOWN state if an error occurs:

```
1> resume
2> go
Msg 32000, Level 20, State 0:
Server 'rao', Procedure 'resume', Line 1:
Command <resume> failed - Desired state <REPLICATE>
could not be achieved. Current state: <REPLICATION
DOWN>
```

- 2 The `ra_status` command returns the state of the Replication Agent. It is good practice to verify that the Replication Agent remains in replicating state, even after the resume command executes successfully.

To detect an error that occurred after replication start-up, execute:

```
ra_status
go
```

If the Replication Agent is in replicating state, `ra_status` returns:

```
State          Action
-----
```

REPLICATING Ready to replicate data.

Replication Agent returns REPLICATION DOWN state if an error occurs.

```
1> resume
2> go
Msg 32000, Level 20, State 0:
Server 'rao', Procedure 'resume', Line 1:
Command <resume> failed - Desired state <REPLICATE>
could not be achieved. Current state: <REPLICATION
DOWN>
```

3 Validate that both primary and replicate connections are active:

```
isql -Usa -P -SSAMPLE_RS
admin who
go
```

Note Be aware that:

- The DSI connection for the primary database connection is usually down because you are not replicating data back to the primary database.
 - The Replication Agent connection, if established for the replicate database connection, is usually down, because you are not replicating data from the replicate database.
-

Do not proceed until admin who has similar status for threads to the following:

```
admin who
go
```

The following appears:

```
Spid Name State Info
-----
-----
13 DSI EXEC Awaiting Command 101(1)
SAMPLE_RS_ERSSD.SAMPLE_RS_ERSSD

9 DSI Awaiting Message 101
SAMPLE_RS_ERSSD.SAMPLE_RS_ERSSD

8 SQM Awaiting Message 101:0
SAMPLE_RS_ERSSD.SAMPLE_RS_ERSSD

8 SQM Awaiting Message 101:0
```

```
SAMPLE_RS_ERSSD.SAMPLE_RS_ERSSD

54 DSI EXEC Awaiting Command 102(1)
my_mssql_access_service.rdb

53 DSI Awaiting Message 102 my_mssql_access_service.rdb

17 SQM Awaiting Message 102:0 my_mssql_access_service.rdb DSI
EXEC Suspended 103(1) NY.NYmss5

DSI Suspended 103 NY.NYmss5

24 DIST Awaiting Wakeup 103 NY.NYmss5

25 SQT Awaiting Wakeup 103:1 DIST NY.NYmss5

23 SQM Awaiting Message 103:1 NY.NYmss5

22 SQM Awaiting Message 103:0 NY.NYmss5

62 REP AGENT Awaiting Command NY.NYmss5
```

Testing replication

After you finish setting up the replication system, you can test replication.

❖ Testing replication

- 1 Connect to the primary Microsoft SQL Server database as a regular user, not the maintenance user. Make sure the regular user also exists in the replicate database.
- 2 Create a test table to replicate in the primary database:

```
create table T1( a int, b char(10) ),
go
```
- 3 Grant permissions to any new or existing object to be replicated in the primary database:

```
grant all on T1 to public
go
```
- 4 Connect to the replicate Microsoft SQL Server database as a regular user, not the maintenance user.

- 5 Create a test table in the replicate database:

```
create table T1 (a int b char(10))
go
```

- 6 Grant permissions to any new or existing object to be replicated in the replication database so that the Replication Server maintenance user can update this table:

```
grant all on T1 to public
go
```

- 7 Connect to the Replication Agent and run the following command to mark the table:

```
pdb_setreptable T1, mark
```

- 8 After the table is marked and the Replication Agent is in a replicating state, insert test data into the test table and commit it.

By default, the work performed by the maintenance user of the primary connection is not replicated. The user ID used to insert transactions cannot be the same as the maintenance user defined in the primary connection. See “Configuring Replication Server for replication from the primary database” on page 53.

Replication Agent applies only committed transactions to a replicate database.

```
insert into T1 values ( 42, 'foo' )
go
```

- 9 Use your preferred Microsoft SQL Server query tool to examine the replicate site for results, and compare the contents of your test table from both the primary and replicate sites.

Resetting the primary Microsoft SQL Server database for replication

In a test environment, you may occasionally need to reset the replication environment. Instead of deleting and re-creating a new Replication Agent instance, use this procedure to facilitate resetting the environment.

❖ Resetting the primary database for replication

- 1 Protect your new environment from old log information by using the following command in the Replication Agent to archive all current *redo* log data:

```
pdb_xlog move_truncpt
```

- 2 To retain marking and log device information, reinitialize the Replication Agent using `pdb_xlog init` with the `force` option, which forces the Replication Agent repository to be refreshed instead of overwritten:

```
pdb_xlog init, force
```

Note If you prefer to delete and replace all the information in the Replication Agent repository, issue the `pdb_xlog remove, force` command followed by a normal `pdb_xlog init` command (without the `force` option).

- 3 Reset the locator stored in Replication Server:

```
isql -USAMPLE_RS_RSSD_prim -PSAMPLE_RS_RSSD_prim_ps  
-SSAMPLE_RS_ERSSD -DSAMPLE_RS_ERSSD
```

```
rs_zeroltm NY, NYmss5  
go
```

The following appears:

```
Locator has been reset to zero.  
(return status = 0)
```

Setting Up Replication for IBM DB2 Universal Database

This chapter identifies the components that are required to implement a Sybase replication system for the IBM DB2 Universal Database on UNIX, Linux, or Microsoft Windows, as well as an overview of the tasks and instructions for installing and configuring a sample replication environment for IBM DB2 Universal Database.

Topic	Page
Sybase replication system	73
Prerequisites	74
Installing replication components	75
Configuring replication components	87
Testing replication	113

Note Use the procedures in this chapter only for proof-of-concept (POC) or testing, not for production.

Sybase replication system

The components required to implement a replication system are:

- A primary IBM DB2 Universal Database
- A replicate IBM DB2 Universal Database
- A Replication Server
- The Replication Server Options components:
 - Replication Agent
 - ECDA Option for ODBC

Figure 3-1 illustrates a Sybase replication system with IBM DB2 Universal Database. It shows the flow of data between the databases and the Replication Agent, Replication Server, and ECDA database gateway.

Figure 3-1: Sybase replication system for IBM DB2 Universal Database

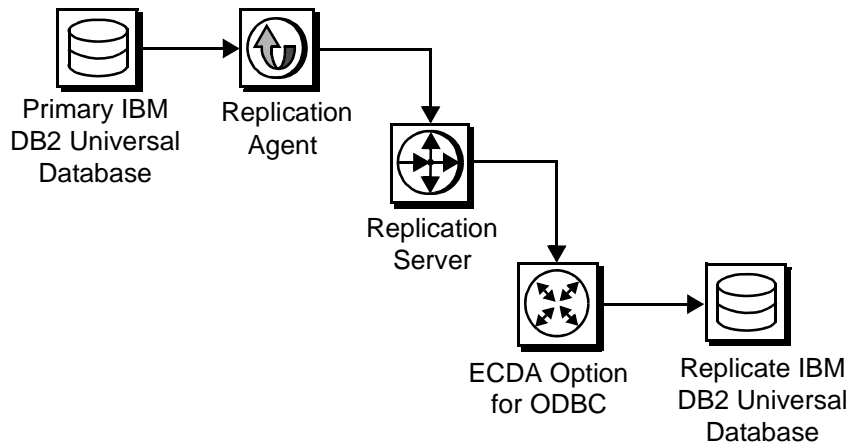

Prerequisites

Before you begin setting up the replication system, be familiar with the IBM DB2 Universal Database and have an understanding of Sybase replication. In addition:

- You have obtained the licenses for the Replication Server and the Replication Server Options.
- IBM DB2 Universal Database 9.1 or 9.5 must be installed and configured, to serve as the source (primary) database and as the target (replicate) database.
- TCP/IP connectivity must be available.
- Any OS patches required for Java 6.0 have been installed.

During this procedure, Sybase recommends that you do not use Replication Server reserved words for object names and connection names. A complete list of reserved words is in the *Replication Server Reference Manual*.

System requirements

The target computer on which you are installing the replication components must meet the following memory and disk space requirements:

For Windows

Table 3-1: Windows memory and disk requirements

Components	Memory (RAM)	Disk space
Replication Server	512MB	380MB
ECDA	512MB	440MB
Replication Agent	512MB	300MB

For UNIX

Table 3-2: UNIX memory and disk requirements

Components	Memory (RAM)	Disk space
Replication Server	512MB	520MB
ECDA	256MB	700MB
Replication Agent	512MB	300MB

For Linux

Table 3-3: Linux memory and disk requirements

Components	Memory (RAM)	Disk space
Replication Server	512MB	400MB
ECDA	256MB	590MB
Replication Agent	512MB	300MB

To improve performance by avoiding multiple network hops, Sybase recommends that Replication Server, ECDA for ODBC, and the target database reside on the same machine.

See *Replication Server Options 15.5 Release Bulletin*.

Installing replication components

For the quick-start process, Sybase recommends that you install all replication components on the same host where an IBM DB2 Universal Database server has already been installed and is running with both the primary and the replicate databases. This simplifies the quick-start process and avoids the step of separately installing IBM DB2 Universal Database clients for Replication Agent and for ECDA Option for ODBC.

Identifying the Sybase installation directory

Replication Agent, Replication Server, and ECDA are installed in the same base directory, which is identified by the SYBASE environment variable. Select a path on the host drive to be the recipient of the Sybase installation and configuration activities.

Accessing products from the SPDC

If you are not using installation CDs, go to the Sybase Product Download Center (SPDC) Web site to obtain replication software.

❖ Downloading the replication software

Note This procedure requires you to repeat steps to download two products: Replication Server and Replication Server Options.

You must have a login ID and password to download software from the SPDC.

- 1 Go to SPDC at <https://sybase.subscribenet.com/control/sybs/login> and enter your login ID and password.

The Product List page appears.

- 2 Select Replication Server.

The high-level Product Information page appears.

- 3 Select Replication Server again.

The detailed Product Information page appears.

- 4 Select the Replication Server software you need by primary database, version, and platform (return later to this detailed Product Information page to select Replication Server Options software).

The Software Terms and Conditions page appears, listing countries and regions.

- 5 Either:

- Select I Agree to accept the terms without reading them, go to the Product Download Page, and continue with step 6, or
- Select your country or region to read the terms.

The software licence agreement for the software appears. Read the terms and either:

- Select I Agree to accept the terms, go to the Product Download Page, and continue with step 6, or
 - Select Cancel to return to the high-level Product Information page.
- 6 The Product Download Page lists the software and documentation for the product. Select FTP Download or Advanced Download Options for the Replication Server software to download and save the compressed files to your local drive.

Note For each product, the documentation download contains installation-related documents, and the SyBooks download contains the rest of the documentation set.

- 7 Return to the detailed Product Information page that you accessed in step 3 and select the Replication Server Options software by primary database, version, and platform.

The Software Terms and Conditions page appears, listing countries and regions.

- 8 Navigate the Software Terms and Conditions pages as you did in step 5.
- 9 At the Product Download Page, select FTP Download or Advanced Download Options for the components of Replication Server Options to download and save the compressed files to your local drive:
- Replication Agent 15.5
 - ECDA Options 15.0
 - DirectConnect Client 15.0
- 10 Uncompress and extract all the installation images to your local drive.
- 11 Download the ECDA 15.0 ESD #3:
- a Point your Web browser to the Sybase Support Page at <http://www.sybase.com/support>.
 - b Select EBFs/Maintenance. If prompted, enter your MySybase user name and password.
 - c Select EnterpriseConnect Data Access. A list of EBFs and maintenance releases appears.

- d Find the EBF containing the ECDA 15.0 ESD #3 for your platform, for example:

EBF *xxxxx*: 15.0 ESD #3

Here, *xxxxx* is the number of the EBF containing the ECDA 15.0 ESD #3 for your platform.

- e Click the Info icon to display the EBF/Maintenance report, and click the product description to download the software.

Installing Replication Agent

If Replication Agent is already installed, go to “Installing Replication Server” on page 81.

Installing the Replication Agent creates a directory structure containing the Replication Agent binaries, scripts, JRE, and associated files. There are no configuration steps during installation.

❖ Installing Replication Agent software

- 1 Use one of the following methods to install the software.
 - After following the download instructions in “Accessing products from the SPDC” on page 76, go to the location where you extracted the Replication Agent 15.5 installation image, or
 - Insert the Replication Agent CD into your CD drive.
- 2 Execute the setup routine.
 - For UNIX or Linux (GUI mode):

```
./setup
```
 - For Windows:

```
setup
```
- 3 If you see an error message saying that there is not enough temporary disk space, add the following to your setup command:
 - For UNIX or Linux:

```
./setup -is:tempdir tempDirectory
```
 - For Windows:

```
setup -is:tempdir tempDirectory
```

Here, *tempDirectory* is a directory with at least 100MB of disk space that the installation program can use.

Note If you are installing from a remote machine and do not have an X-Windows client, execute `./setup -console`, to run in console mode.

- 4 On the Welcome window, click Next.
- 5 Select a geographic location that displays the license agreement. Select I Agree, and click Next.
- 6 Enter the directory where you want to install Replication Agent:
 - If the directory does not exist, the installation program prompts you to create it. Click Yes.
 - If the destination directory exists, you receive a warning message that you are installing into an existing directory. Click Next.
- 7 Select Typical for the installation setup type, and click Next.
- 8 On the Sybase Software Asset Management License Server window, use one of these options to enter the license:
 - Specify license keys – click Browse to select the license file.
Alternatively, copy and paste the license information directly in the license pane. Click Next to proceed.
 - Use previously deployed license server – if you have a previously deployed license server, enter the host name of the machine where the license server is running, and the port number if the port number you are using is not default. Click Next.
 - Continue installation without a license key – if you do not have a license, you can select this option, and click Next to proceed. The installer allows you to install and use Replication Agent without a license for a grace period of 30 days. To continue using Replication Agent after the end of the grace period, obtain valid license from the SPDC, and install it.

For more information on SySAM licensing, see the *Sybase Software Asset Management Users Guide*.
- 9 The SySAM notification window prompts you to configure your server for e-mail notification. When configuration is enabled, you receive information about license management events that require attention. At the SySAM notification window, do one of the following:

- Select Yes and either accept the default values that are supplied, or enter values for the following:
 - SMTP server host name
 - SMTP server port number
 - Sender e-mail address
 - Recipient e-mail address
 - Message severity level of an event that triggers an e-mail message. Your choices are:
 - Informational
 - Warning
 - Error
- If you choose not to have e-mail alerts or severity messages logged, select No.

Click Next.

- 10 The installation program displays a summary of what is to be installed. Click Install.
- 11 The installation program starts to install Replication Agent, displaying the progress status. Click No to All, if you see the following message:

There are newer files already installed. Do you want to replace them?
- 12 When you receive a message indicating that Replication Agent was successfully installed, click Done.

See the *Replication Agent Installation Guide*.

❖ **Verifying the installation**

- 1 Change to the directory where you installed Replication Agent.
- 2 Set the environment variables by sourcing the *SYBASE.csh* file (UNIX or Linux) or by executing the *SYBASE.bat* file (Windows).
- 3 Change to *\$SYBASE/RAX-15_5/bin* (UNIX or Linux) or *%SYBASE%\RAX-15_5\bin* (Windows).
- 4 Obtain the Replication Agent version string.

- For UNIX or Linux:

```
./ra.sh -v
```

- For Windows:

```
ra -v
```

If Replication Agent installs successfully, you see the Sybase copyright and the Replication Agent version string.

Installing Replication Server

If Replication Server is already installed go to “Installing ECDA Option for ODBC” on page 84.

While installing Replication Server:

- Allocate a disk partition of at least 20MB for each Replication Server you are installing. You can add more partitions later, if necessary. Check each partition to make sure it is available and has write permissions.

Allocate the entire partition to the Replication Server. If you allocate only a portion of the partition to Replication Server, you cannot use the remainder for any other purpose.

❖ Installing Replication Server

- 1 Use one of the following methods to install the software:
 - After following the download instructions in “Accessing products from the SPDC” on page 76, go to the location where you extracted the Replication Server 15.5 installation image, or
 - Insert the Replication Server CD in your CD drive.
- 2 Execute the setup routine.
 - For UNIX or Linux (GUI mode):

```
./setup
```
 - For Windows:

```
setup
```
- 3 If you see an error message saying that there is not enough temporary disk space, add the following to your setup command:
 - For UNIX or Linux:

```
./setup -is:tempdir tempDirectory
```
 - For Windows:

```
setup -is:tempdir tempDirectory
```

Here, *tempDirectory* is a directory with at least 100MB of disk space that the installation program can use.

- 4 On the Welcome window, click Next.
- 5 Select a geographic location that displays the license agreement. Select I agree, and click Next.
- 6 Enter the directory where you want to install Replication Server:
 - If the directory does not exist, the installation program prompts you to create it. Click Yes.
 - If the destination directory exists, you receive a warning message that you are installing into an existing directory. Click Yes.
- 7 Select Typical for the installation setup type, and click Next.
- 8 The installation program displays a summary of what is to be installed. Click Next.
- 9 The installation program starts to install Replication Server, displaying the progress status. You may see the following message:

```
There are newer files already installed. Do you want  
to replace them?
```

Click No to All.

- 10 When you receive a message indicating that Replication Server software has successfully installed, click Next.

Note This procedure uses the SAMPLE_RS Replication Server.

- 11 The SySAM License Server window opens and displays this prompt:

```
Will licenses be obtained from the License Server?
```

Respond based on how you set up your environment and use the license obtained from the Sybase Product Download Center (SPDC) Web site for Replication Server.

Click Next.

- 12 The SySAM notification window prompts you to configure your server for e-mail notification. When configuration is enabled, you receive information about license management events that require attention. Select Yes, and either accept the default values that are supplied, or enter the following values:

- SMTP server host name
- SMTP server port number
- Sender e-mail address
- Recipient e-mail address
- Message severity level of an event that triggers an e-mail message. Your choices are:
 - Informational
 - Warning
 - Error

If you choose not to have e-mail alerts or severity messages logged, select No.

Click Next.

- 13 To start a sample Replication Server, select Yes, and click Next.
- 14 This information appears and should be recorded:

This page contains detailed information regarding the sample Replication Server. Please record this information.

The sample Replication Server will be called SAMPLE_RS and will run on port 11752. It will be configured with a user of sa and no password.

The sample Replication Server will use an embedded RSSD called SAMPLE_RS_ERSSD that runs on port 11751. It will be configured with a user of SAMPLE_RS_RSSD_prim and a password of SAMPLE_RS_RSSD_prim_ps.

The installer has updated the appropriate interfaces file or sql.ini file.

All files and logs associated with the sample Replication Server will be located in the directory <samp_repserver>.

The sample Replication Server will be configured using the file `<SAMPLE_RS.res>`.

Here, `<samp_repserver>` and `<SAMPLE_RS.res>` are paths to the sample Replication Server and sample Replication Server configuration file, respectively.

Click Next.

- 15 When the sample Replication Server is running and an “Installation was successful” message appears, click Finish.

❖ Verifying the installation

- 1 Change to the directory where you installed Replication Server.
- 2 Set the environment variables by sourcing the `SYBASE.csh` file (UNIX or Linux) or by executing the `SYBASE.bat` file (Windows).

- 3 Log in to Replication Server:

```
isql -Usa -P -SSAMPLE_RS
```

- 4 Verify the Replication Server version:

```
admin version  
go
```

- 5 Exit the isql session with the quit command.

Installing ECDA Option for ODBC

If ECDA Option for ODBC is already installed, go to “Configuring replication components” on page 87.

When installing ECDA Option for ODBC, install ECDA on the same server as the replicate database. This eliminates a network hop and improves performance.

❖ Installing ECDA for ODBC in GUI mode

Note To install using the console mode or a response file, see the *ECDA Installation Guide* for Linux and UNIX.

- 1 Use one of the following methods to install the software:

- After following the download instructions in “Accessing products from the SPDC” on page 76, go to the location where you extracted the ECDA Option for ODBC 15.0 installation image.
 - Insert the CD labeled ECDA 15.0 Option for ODBC.
- 2 Execute the setup routine:
 - For UNIX or Linux:

```
./setup
```
 - For Windows:

```
setup
```
 - 3 If you see an error message saying that there is not enough temporary disk space, add the following to your setup command:
 - For UNIX or Linux:

```
./setup -is:tempdir tempDirectory
```
 - For Windows:

```
setup -is:tempdir tempDirectory
```

Here, *tempDirectory* is a directory with at least 100MB of disk space that the installation program can use.

- 4 On the Welcome window, click Next.
- 5 Select a geographic location that displays the license agreement. Select I agree, and click Next.
- 6 Enter the directory where you want to install ECDA:
 - In the destination directory, enter the base directory identified by the SYBASE environment variable. Click Yes to install over an existing directory.
 - If the destination directory exists, you receive a warning message that you are installing into an existing directory. Click Yes.
- 7 Select Custom setup, and click Next.
- 8 Unselect ECDA Option for Oracle, and click Next.
- 9 Verify the modules to install. Click Next.

You may receive a message:

```
There are newer files already installed. Do you want  
to replace them?
```

Click No to All.

- 10 When you receive a message that the installation was successful, click Next.

- 11 The SySAM License Server window opens and displays this prompt:

`Will licenses be obtained from the License Server?`

Respond based on how you set up your environment, and use the license obtained from the Software Product Download Center (SPDC) Web site for Replication Server Options.

Click Next.

- 12 The SySAM notification window prompts you to configure your server for e-mail notification. When configuration is enabled, you receive information about license management events that require attention. Select Yes and either accept the default values that are supplied, or enter values for the following:

- SMTP server host name
- SMTP server port number
- Sender e-mail address
- Recipient e-mail address
- Message severity level of an event that triggers an e-mail message. Your choices are:
 - Informational
 - Warning
 - Error

If you choose not to have e-mail alerts or severity messages logged, select No.

Click Next.

- 13 When you receive a message indicating that ECDA was successfully installed, click Finish.

ECDA, including the DirectConnect service, is installed.

- 14 Apply the ECDA 15.0 ESD #3:

- a Extract the `tgz` or `zip` file for the ECDA 15.0 ESD #3 that you downloaded in “Downloading the replication software” on page 76.

- b Go to the directory into which you extracted the zip file.
- c Install the ECDA 15.0 ESD #3 in the same way that you installed ECDA earlier in this procedure.

Configuring replication components

This section describes the tasks you must perform to configure each of the replication components in the replication system.

Setting IBM DB2 Universal Database environment variables

For UNIX and Linux, the IBM DB2 Universal Database installation provides two scripts, one of which needs to be sourced to set up the IBM DB2 Universal Database environment variables: *db2cshrc* for C shell and *db2profile* for Bourne or Korn shell. These scripts set the library path environment variable based on the bit size of the server or client that was installed.

Note On Windows, the IBM DB2 Universal Database installation sets all necessary environment variables.

For UNIX and Linux platforms, the 32-bit and 64-bit versions of the driver and API libraries are located in the *\$HOME/sqllib/lib32* and *\$HOME/sqllib/lib64* directories, respectively, where *\$HOME* is the home directory of the IBM DB2 Universal Database instance owner. If Replication Agent is installed on AIX, Solaris, or HP Itanium, the library path environment variable must point to the 64-bit libraries. For all other platforms, the library path environment variable must point to the 32-bit libraries.

Note If Replication Agent is installed on Solaris, AIX or HP Itanium, a 64-bit IBM DB2 Universal Database instance must be configured. This can be a server or client instance.

To correctly set the IBM DB2 Universal Database environment variables for Replication Agent and ECDA, you may need to customize either *db2cshrc* or *db2profile*. However, do not change the original scripts, because they may be changed when you apply a FixPak to the IBM DB2 Universal Database server or client.

Note Replication Agent requires 32-bit libraries for Linux and Windows and 64-bit libraries for UNIX. Because ECDA may have different requirements, you may want to maintain two separate customized copies of the aforementioned scripts, one copy for Replication Agent and one for ECDA.

❖ **Setting IBM DB2 Universal Database environment variables to use 32-bit libraries on UNIX or Linux**

- 1 Navigate to the IBM DB2 Universal Database server or IBM DB2 Universal Database client *sqllib* directory, which is located in the IBM DB2 Universal Database instance owner user home directory. For example:

```
cd /db2home/db2inst1/sqllib
```

- 2 Based on the type of UNIX shell you are using, copy either the *db2cshrc* or *db2profile* script:

- For C shell:

```
cp db2cshrc mydb2cshrc
```

- For Bourne or Korn shell

```
cp db2profile mydb2profile
```

- 3 Edit your copy of the file. Add a statement at the very end of the file that sets the platform-specific library path variable to point to the 32-bit IBM DB2 Universal Database libraries. For example, on Solaris or Linux, add these lines:

- For C shell, in *mydb2cshrc*:

```
# force 32-bit libraries
setenv LD_LIBRARY_PATH $HOME/sqllib/lib32:$LD_LIBRARY_PATH
```

Here, *\$HOME* is the home directory of the IBM DB2 Universal Database instance owner.

- For Bourne or Korn shell, in *mydb2profile*:

```
# force 32-bit libraries
LD_LIBRARY_PATH=$HOME/sqllib/lib32:$LD_LIBRARY_PATH
```

```
export LD_LIBRARY_PATH
```

- 4 Before starting either Replication Agent or ECDA, always source your file, if you have customized it. Otherwise, source the original *db2cshrc* or *db2profile* script.

Cataloging a node and a database in an IBM DB2 Universal Database client

To access their respective IBM DB2 Universal Databases, both the Replication Agent for UDB and ECDA Option for ODBC must use IBM DB2 Universal Database client libraries. The process of cataloging configures an IBM DB2 Universal Database client so that it knows how to connect to a particular database. This process also creates a database alias, which Replication Agent or ECDA uses as the data source name.

By default, IBM DB2 Universal Database client libraries are installed when the IBM DB2 Universal Database server is installed. In addition, an IBM DB2 Universal Database client can be separately installed on a host other than the one on which the IBM DB2 Universal Database server is installed. In either case, cataloging must be performed in the IBM DB2 Universal Database client that Replication Agent or ECDA is using. If Replication Agent and ECDA are installed on different hosts, they are using different IBM DB2 Universal Database clients, so the cataloging must be performed in both of the IBM DB2 Universal Database clients.

If the IBM DB2 Universal Database client and the IBM DB2 Universal Database server are on the same host, and there is only one IBM DB2 Universal Database server running, cataloging may have been performed when the IBM DB2 Universal Database instance was installed and the databases configured. If so, then no further cataloging needs to be performed.

❖ Cataloging a node in an IBM DB2 Universal Database client

- 1 On UNIX or Linux, navigate to the IBM DB2 Universal Database server or IBM DB2 Universal Database client *sqllib* directory, which is located in the IBM DB2 Universal Database instance owner user home directory. For example, on UNIX:

```
cd /db2home/db2inst1/sqllib
```

- 2 On UNIX or Linux, set the IBM DB2 Universal Database environment variables by sourcing the appropriate script:
 - For C shell:

```
source db2cshrc
```

- For Bourne or Korn shell:

```
. db2profile
```

If necessary, log in to the operating system as the IBM DB2 Universal Database instance owner. Logging in sets up all the IBM DB2 Universal Database environment variables.

Note On Windows, the IBM DB2 Universal Database installation sets up all necessary environment variables.

- 3 Start the IBM DB2 Universal Database command line processor (CLP).

- On UNIX or Linux, enter the following command:

```
db2
```

- On Windows, select Start | Programs | IBM DB2 | Command Line Tools | Command Line Processor.

- 4 Determine if the desired IBM DB2 Universal Database node has already been cataloged. At the CLP prompt, enter:

```
list node directory
```

If a node has already been cataloged, depending on whether the node is local (first entry below) or remote (second entry below), you see results similar to this:

Node 1 entry:

```
Node name           = DB2NODE1
Comment             =
Directory entry type = LOCAL
Protocol            = LOCAL
Instance name       = DB2_01
```

Node 2 entry:

```
Node name           = DB2NODE2
Comment             =
Directory entry type = LOCAL
Protocol            = TCPIP
Hostname            = 10.22.85.228
Service name        = 50001
```

- 5 If your desired node is not listed, catalog it at the CLP prompt.

- To catalog a local node, issue this command:

```
CATALOG LOCAL NODE node_name INSTANCE db2_instance_name
```

where:

- *node_name* is the name of the node on the local host.
- *db2_instance_name* is the name of the associated DB2 instance.
- To catalog a remote node, issue this command:

```
CATALOG TCPIP NODE node_name REMOTE ip_address SERVER port_number
```

where:

- *node_name* is the name of the node on the remote host.
 - *ip_address* is either the IP address or name of the host on which the remote node is running.
 - *port_number* is the port on which the remote node is listening for client connections.
- 6 Verify that the node has been cataloged by issuing the list node directory command again.

❖ **Cataloging a database in an IBM DB2 Universal Database client**

- 1 Determine if the database has already been cataloged. At the CLP command prompt, execute this command:

```
list database directory
```

Depending on whether the database is local (first entry below) or remote (second entry below), you see results similar to this:

Database 1 entry:

```
Database alias           = GRP_DB
Database name           = GRP_DB
Local database directory = /db2home/db2inst1
Database release level  = b.00
Comment                 = UTF-8(Unicode DB)
Directory entry type    = Indirect
Catalog database partition number = 0
Alternate server hostname =
Alternate server port number =
```

Database 2 entry:

```
Database alias           = DB1V9_DS
```

```
Database name           = DB1_V9
Node name               = DB2NODE2
Database release level  = b.00
Comment                 =
Directory entry type    = Remote
Catalog database partition number = -1
Alternate server hostname =
Alternate server port number =
```

- 2 If your desired database is not listed or does not have a database alias, catalog it at the CLP prompt.

- To catalog a database using the default alias, which is the same as the database name:

```
CATALOG DATABASE database_name AT NODE node_name
```

where:

- *database_name* is the name of either the primary or replicate database.
 - *node_name* is the name of the node that contains the database.
- To catalog a database with a specific alias:

```
CATALOG DATABASE database_name AS my_alias AT NODE node_name
```

where:

- *database_name* is the name of either the primary or the replicate database.
 - *my_alias* is your desired alias.
 - *node_name* is the name of the node that contains the database.
- 3 Verify that the database has been cataloged by issuing the list database directory command again.
 - 4 To exit the DB2 CLP, enter the quit command.

Configuring ECDA Option for ODBC

Configuring ECDA Option for ODBC involves:

- 1 Configuring and starting the DirectConnect service
- 2 Creating a maintenance user for replication

Configuring and starting the DirectConnect service

Before you begin to create and configure the DirectConnect service, make sure that:

- The DB2 client has been configured as described in “Cataloging a node and a database in an IBM DB2 Universal Database client” on page 89.
- The port to be used by the DirectConnect service is unused and available.

❖ Creating and configuring a DirectConnect service

1 Start the Create Server wizard:

- For UNIX or Linux:

```
DCWizard.sh
```

- For Windows:

```
DCWizard.bat
```

2 When the Welcome Create Server wizard appears, click Next. The Create DirectConnect Server Options window appears.

3 Select the ECDA Option for ODBC option, and click Next. The Server Name and Port Information window appears.

4 Enter the server name for the new DirectConnect service and the port number that you want the server to “listen” on. Click Next. The ECDA - ODBC Driver Manager Options window appears.

5 Select the unixODBC Driver Manager without a Driver Manager Option, and click Next. The Driver Manager Information window appears.

6 Select the following from the browse files:

- The path to the IBM DB2 Universal Database ODBC Driver file, for example:

```
/software/IBM/db2_09_01/lib/libdb2.so
```

Note Version 9.1 of the HP Itanium IBM DB2 Universal Database ODBC 64-bit driver is named *libdb2o.so*.

- On UNIX or Linux, the DB2 script file that must be sourced before the DirectConnect service is started.

If you have customized the IBM DB2 Universal Database environment script as described in “Setting IBM DB2 Universal Database environment variables” on page 87, use the path to that script. Otherwise, use the path to the original IBM DB2 Universal Database script, either *db2cshrc* or *db2profile*.

For example, to use your customized script for C shell, enter the following:

```
source path/mydb2cshrc
```

Here, *path* is the full path to the directory in which you saved your customized file.

For example, to use the original IBM DB2 Universal Database script for Bourne or Korn shell, enter the following:

```
. path/sqlllib/db2profile
```

Here, *path* is the home directory of the owner of the replicate IBM DB2 Universal Database instance.

- 7 Click Next. The DirectConnect Service Name window appears.
- 8 Enter the ECDA access service name that you want to use for this server, and click Next. The ECDA Server Summary and Build window appears.
- 9 Verify the ECDA Server information that appears:
 - If correct, select Create Server. The Start DirectConnect server (Optional) window appears.
 - If incorrect, click Back to change the information.
- 10 Open the `%SYBASE%\DC-15_0\servername\cfg\dcany.cfg` file (Windows) or the `$SYBASE/DC-15_0/servername/cfg/dcany.cfg` file (UNIX or Linux), where *servername* is the name of the server you created using the DCWizard.
- 11 In the file, locate the name of the IBM DB2 Universal Database access service that you created in step 4 above using the DCWizard. Under that, set the ConnectionSpec1 parameter to the name of the IBM DB2 Universal Database ODBC data source you created. For example:

```
[Service Library]
{Logging}
LogSvcLibStatistics=0
{Client Interaction}
SvcLibDescription=Access Service Library for ODBC
[my_udb_access_service]
```



```
{ACS Required}
ConnectionSpec1=my_udb_datasource_name
```

12 Start the DirectConnect service:

- a Navigate to the DirectConnect installation directory, for example:

```
cd /software/sybase/DC-15_0
```

- b Execute the *DC_SYBASE.csh* (UNIX or Linux) or *DC_SYBASE.bat* (Windows) script to set the DirectConnect environment variables.

- c Navigate to the DirectConnect *bin* directory.

- d Start the DirectConnect service in the background, which also starts all the configured access services:

```
DCStart -Sservicename &
```

Here, *servicename* is the name of the DirectConnect service.

❖ **Verifying that you can connect to IBM DB2 Universal Database**

- 1 Open a command window in the *\$SYBASE* (UNIX or Linux) or *%SYBASE%* (Windows) directory of your ECDA installation.
- 2 Change to the *\$SYBASE/DC-15_0* (UNIX or Linux) or *%SYBASE%\DC-15_0* (Windows) directory.
- 3 Set the environment variables by sourcing the *\$SYBASE/DC_SYBASE.csh* file (UNIX or Linux) or by running the *%SYBASE%\DC_SYBASE.bat* file (Windows).
- 4 Log in to the IBM DB2 Universal Database through the DirectConnect service:

```
isql -Uvaliduser -Ppassword -SDCService
```

Here, *validuser* and *password* are any valid user and password, and *DCService* is the DirectConnect service name.

- 5 Verify the connection to the replicate IBM DB2 Universal Database:

```
select @@sqldbmsname
go
```

```
SQLDbmsName
-----
DB2/SUN
```

```
select @@sqlbmsver
go

SQLDbmsVer
-----
09.01.0005
```

- 6 Exit the isql session with the quit command.

Creating a maintenance user for replication

The maintenance user is a valid IBM DB2 Universal Database user that the Replication Server uses to apply commands to the replicate IBM DB2 Universal Database. Replication Server requires one maintenance user to be defined for each connection.

A user must already exist on the operating system before it can be added to an IBM DB2 Universal Database. To add an existing operating system user to the database, use the Control Center administration tool, which is included with either the server or client installation of IBM DB2 Universal Database on Microsoft Windows. You may choose to install an IBM DB2 Universal Database client on a Windows machine and use it to administer the IBM DB2 Universal Databases.

❖ Creating a maintenance user in IBM DB2 Universal Database

- 1 Select an existing operating system user to be added to the replicate database as a maintenance user.
- 2 Select Start | Programs | IBM DB2 | Control Center.
- 3 Configure the Control Center administration tool to connect to the replicate IBM DB2 Universal Database according to the IBM documentation. Once the Control Center administration tool has been configured, the replicate database appears in the All Databases view.
- 4 In the Control Center administration tool display window, right-click the replicate database name, and select Authorities from the context menu.
- 5 In the Database Authorities window, click Add User.
- 6 In the Add User window, select the user to add to the database from the list of displayed operating system users, and click OK.

- 7 Click Grant All to add necessary authorities to the maintenance user.

Note In a POC environment, the user is created by an IBM DB2 Universal Database system administrator.

Configuring Replication Server

Configuring Replication Server involves:

- 1 Configuring Replication Server for replication to the target data server
- 2 Configuring Replication Server for replication from the primary database
- 3 Verifying the ECDA installed objects

Configuring Replication Server for replication to the target data server

❖ Creating a Replication Server connection to replicate

- 1 Navigate to the `$$SYBASE/RAX-15_5/scripts/ibmudb` (UNIX or Linux) or `%SYBASE%\REP-15_5\scripts\ibmudb` directory.
- 2 Make a copy of the `udb_create_rs_standby_connection.sql` script named `my_udb_create_rs_standby_connection.sql`.
- 3 Before executing the `my_udb_create_rs_standby_connection.sql` script against your Replication Server, change the name of the connection that Replication Server uses to connect to the DirectConnect service, where:
 - `{rds}.{rdb}` is the DirectConnect service name followed by the replicate database name.
 - `rs_maint_user` and `rs_maint_user_pwd` are the maintenance user and password created in ECDA Option for ODBC, in step 2 of “Configuring ECDA Option for ODBC” on page 92.

For example:

```
create connection to DCService.my_udb_db
using profile rs_udb_to_udb;standard
set username maintuser
set password "password"
```

```
go
```

Note In the above example, *password* is a Replication Server reserved word and, therefore, must be enclosed in double quotes and should match the password specified in the resource file.

- 4 Create the connection to the replicate database:

```
isql -Usa -P -SSAMPLE_RS -i my_udb_create_rs_standby_connection.sql
```

- 5 Log in to SAMPLE_RS and verify the Replication Server connection to the replicate database:

```
isql -Usa -P -SSAMPLE_RS
admin who
go
```

You should see a message returned for the DSI connection *{rds}.{rdb}*. Verify that the status is “Awaiting Message” or “Awaiting Command.”

- 6 Exit the isql session with the quit command.

Configuring Replication Server for replication from the primary database

This section describes the configuration steps required for replication from the primary database. It includes:

- Creating a Replication Server connection to the primary database
- Creating a database replication definition
- Creating the database replication subscription

❖ Creating a Replication Server connection to the primary database

- 1 Go to the `$$SYBASE/RAX-15_5/scripts/sybase` (UNIX or Linux) or `%SYBASE%\RAX-15_5\scripts\sybase` (Windows) directory.
- 2 Make a copy of the `rs_create_test_primary_connection.sql` script named `my_udb_rs_create_test_primary_connection.sql`.
- 3 Before executing the `my_udb_rs_create_test_primary_connection.sql` script against your Replication Server, change all occurrences of value `{rax}.{test}` to the name of the Replication Server connection between it and Replication Agent for UDB, where:
 - *rax* is the name of the data server of the primary IBM DB2 Universal Database.

- *test* is the name of the primary IBM DB2 Universal Database.

For example, *NY.NYudb9*.

Note Save these values to be used later for the *rs_source_ds* and *rs_source_db* parameters in the Replication Agent *ibmudb.rs* file.

- 4 Change *sys* and *sys_pwd* to the user ID and password of the IBM DB2 Universal Database user who must have permission to apply DML operations against all user tables to be replicated, where:
 - *sys* is the user ID of the IBM DB2 Universal Database user (*sys*).
 - *sys_pwd* is the password of the IBM DB2 Universal Database user (*change_on_install*).

Note This user must be a valid user in the IBM DB2 Universal Database.

The following command creates a Replication Server connection to the primary database example:

```
create connection to NY.NYudb9
set error class rs_sqlserver_error_class
set function string class rs_udb9_function_class
set username sys
set password change_on_install
with log transfer on, dsi_suspended
go
```

- 5 Execute this script in Replication Server:

```
isql -Usa -P -SSAMPLE_RS -i my_udb_rs_create_test_primary_connection.sql
```

A message appears that indicates the Replication Server connection to the primary database has been created.

❖ Creating the database replication definition

- 1 Navigate to the `$$SYBASE/RAX-15_5/script/sybase` (UNIX or Linux) or `$$SYBASE%\RAX-15_5\script\sybase` (Windows) directory.
- 2 Make a copy of the *rs_create_test_db_repdef.sql* script named *my_udb_rs_create_test_db_repdef.sql*.
- 3 Before executing the *my_udb_rs_create_test_db_repdef.sql* script, change the value of *{pds}.**{pdb}* to the name of the connection string you defined for the primary database, where:

- *pds* is the name of the data server of the primary IBM DB2 Universal Database.
- *pdb* is the name of the primary IBM DB2 Universal Database.

For example, *NY.NYudb9*.

Note Save these values to be used later for the *rs_source_ds* and *rs_source_db* parameters in the Replication Agent *ibmudb.rs* file.

This is a database replication definition example:

```
create database replication definition NY_repdef1
with primary at NY.NYudb9
go
```

4 Connect to the Replication Server and enter:

```
isql -Usa -P -SSAMPLE_RS -i my_udb_rs_create_test_db_repdef.sql
```

A message appears that indicates the database replication definition has been created.

❖ Creating the database replication subscription

- 1 Make a copy of the *rs_create_test_db_sub.sql* script named *my_udb_rs_create_test_db_sub.sql*.
- 2 Before executing the *my_udb_rs_create_test_db_sub.sql* script, change the *{pds}*.*{pdb}* and *{rds}*.*{rdb}* to the appropriate connection name, where:
 - *pds* is the name of the data server of the primary IBM DB2 Universal Database.
 - *pdb* is the name of the primary IBM DB2 Universal Database.
 - *rds* is the DirectConnect service name.
 - *rdb* is any valid identifier. Sybase recommends that you use the IBM DB2 Universal Database replicate database name.

Note Save these values to be used later in the Replication Agent *ibmudb.rs* file.

Here is an example of create database replication subscription:

```
create subscription NY_sub1
for database replication definition NY_repdef1
```

```
with primary at NY.NYudb9
with replicate at DCService.udb_db
without materialization
go
```

3 Connect to Replication Server and execute:

```
isql -Usa -P -SSAMPLE_RS -i my_udb_rs_create_test_db_sub.sql
```

A message appears that indicates the subscription is being created.

Verifying the ECDA installed objects

❖ Verifying the ECDA installed objects

1 Log in to IBM DB2 Universal Database through ECDA as *maintuser*.

- To verify whether the *rs_info* table has been created successfully, enter:

```
isql -Umaintuser -Ppassword -SDCService
select * from rs_info
go
```

This is returned:

```
RSKEY          RSVAL
-----
charset_name   iso_1
sortorder_name bin_iso_1
(2 rows affected)
```

- To verify whether the *rs_lastcommit* table has been created successfully, enter:

```
isql -Umaintuser -Ppassword -SDCService
select * from rs_lastcommit
go
```

The following is returned:

```
ORIGIN  ORIGIN_QID  SECONDARY_QID  ORIGIN_TIME
DEST_COMMIT_TIME
-----
(0 rows affected)
```

If the ECDA objects are not installed successfully, no results appear, and you see an error message.

- 2 Exit the isql session with the quit command.

Configuring Replication Agent

Configuring Replication Agent involves:

- 1 Configuring and verifying the primary IBM DB2 Universal Database for replication
- 2 Creating the Replication Agent instance
- 3 Verifying the Replication Agent instance
- 4 Initializing the Replication Agent instance

Configuring and verifying the primary IBM DB2 Universal Database for replication

Before you install Replication Agent, configure the primary IBM DB2 Universal Database for replication. To do so, you may need to connect to the primary database using the primary database instance owner user.

❖ **Verifying the current archive setting of the transaction log**

Replication Agent requires that the primary IBM DB2 Universal Database transaction logging be archive logging, not circular logging.

- 1 Determine the LOGARCHMETH1 setting.
 - a Connect to the database by entering the following command at the CLP prompt.

```
CONNECT TO dbalias USER db2_user USING  
db2_user_ps
```

Here, *dbalias* is the cataloged alias of the primary database, *db2_user* is the primary database user, and *db2_user_ps* is the password.

- b Determine the LOGARCHMETH1 setting:

```
GET DB CFG FOR dbalias
```
- 2 If the results do not show that LOGARCHMETH1 is set to LOGRETAIN or to the path name of the directory to which logs are archived, set it:

- To use the default archive location:

```
UPDATE DATABASE CONFIGURATION USING logarchmeth1 LOGRETAIN
```

- To use a specific archive location:

```
UPDATE DATABASE CONFIGURATION USING logarchmeth1 DISK:path
```

Here, *path* is the full path name of the directory where the archive logs are to be stored.

❖ **Setting the IBM DB2 Universal Database connectivity *autocommit* parameter**

Replication Agent requires that the IBM DB2 Universal Database connectivity *autocommit* parameter be turned on (*autocommit=1*). The *autocommit* parameter is specified in the DB2 call-level interface (CLI) configuration file for the primary database. If the *autocommit* parameter is not turned on, a deadlock problem may occur.

- To set the *autocommit* parameter, edit the *db2cli.ini* file. It is located in *<HOME>\sqlib*, where *<HOME>* is the home directory of the IBM DB2 Universal Database instance owner (UNIX or Linux) or the IBM DB2 Universal Database client or server installation directory (Windows).

❖ **Creating an IBM DB2 Universal Database user and grant permissions**

Replication Agent requires an IBM DB2 Universal Database login that has permission to access data and create new objects in the primary database. The IBM DB2 Universal Database login must have SYSADM or DBADM authority to access the primary database transaction log.

- 1 Create a new operating system user named *ra_user* using commands appropriate for your operating system.

For example, the following command can be used to create a user named *ra_user* on the UNIX and Linux operating systems:

```
useradd -gusers -Gmgmt -s/bin/shell -psybase
-d/home/ra_user -m ra_user
```

Here, *password* is the password corresponding to the *ra_user* user name.

- 2 Select Start | Programs | IBM DB2 | Control Center.
- 3 Configure the Control Center administration tool to connect to the primary IBM DB2 Universal Database according to the IBM documentation. Once the Control Center administration tool has been configured, the primary database appears in the All Databases view.
- 4 In the Control Center administration tool display window, right-click the primary database name, and select Authorities from the context menu.

- 5 In the Database Authorities window, click Add User.
- 6 In the Add User window, select *ra_user* from the list of displayed operating system users, and click OK.
- 7 Click Grant All to add necessary authorities to *ra_user*.

Note In a POC environment, the user is created by an IBM DB2 Universal Database system administrator.

❖ **Adding a temporary tablespace to the primary database**

- 1 In the Control Center All Databases view, right-click the Table Spaces folder under your primary database, and select Create from the context menu.
- 2 In the Name window, specify a name for the new table space, and select the Let DB2 Manage My Storage radio button. Click Next.
- 3 In the Type window, select User Temporary, and click Next.
- 4 In the Buffer Pool window, click Create.
- 5 In the Create Buffer Pool window, specify a name for the buffer pool, specify at least 8KB as the page size in the drop-down menu, select Create Bufferpool Immediately, and click OK.
- 6 Click Finish to create the table space. The new table space appears in the Table Spaces folder.

Creating the Replication Agent instance

A single installation of the Replication Agent can support replication from multiple databases. However, one Replication Agent instance is needed for each IBM DB2 Universal Database that is to be replicated.

Note To replicate from multiple databases, using one Replication Agent instance for each database, you must create a separate IBM DB2 Universal Database user for each primary database, as described in “Creating an IBM DB2 Universal Database user and grant permissions” on page 103. You cannot use the same user for multiple Replication Agents.

❖ **Preparing the Replication Agent instance**

- 1 Locate the resource file template.

The majority of configuration values required to create and initialize a Replication Agent can be recorded and stored in a resource file. Using a resource file provides a way to record or retain the configuration information for a Replication Agent instance, allowing an instance to be removed and re-created.

The resource file template for an IBM DB2 Universal Database instance is `$SYBASE/RAX-15_5/init/ibmudb.rs` (UNIX or Linux) or `%SYBASE%\RAX-15_5\init\ibmudb.rs` (Windows).

2 Create an instance resource file:

Copy the resource file template to another file that contains the configuration information for a new instance, for example, *myra.rs*.

Change the values assigned to properties in the resource file so they match the values required for your environment. The majority of these values are host, port, user, and password information for the IBM DB2 Universal Database, Replication Server, and RSSD connections.

- Set the value of `rs_source_ds` to the value you chose for *pds* in previous procedures.
- Set the value of `rs_source_db` to the value you chose for *pdb* in previous procedures.

The resource file is self-documenting, with each parameter described. See the *Replication Agent Administration Guide*.

Note Table 3-4 lists parameters in the order they appear in the resource file, not alphabetically.

Table 3-4: Resource file parameters

Parameter	Description	Example values
instance name	Any valid name.	myra
admin_port	Port number that Replication Agent uses.	9030 (if in use, select a different port number)
pds_host_name	Machine (host) where IBM DB2 Universal Database is installed.	NY
pds_port_number	Port number for IBM DB2 Universal Database.	50007
pds_database_name	Name of the primary database.	NYudb9
pds_username	User ID that Replication Agent uses to access primary data server.	ra_user
pds_password	Password for pds_username.	sybase

Parameter	Description	Example values
pds_datasource_name	Data source name or database alias for the primary database	DBALIAS
rs_host_name	Machine where Replication Server is installed.	jdoe_host1
rs_port_number	Port where Replication Server is installed.	11752
rs_username	Replication Server user with CONNECT SOURCE and CREATE OBJECT capabilities.	SAMPLE_RS_ra
rs_password	Password for rs_username.	SAMPLE_RS_ra_ps
rs_source_ds	Valid name representing data server of primary IBM DB2 Universal Database.	NY
rs_source_db	Valid name representing primary IBM DB2 Universal Database.	NYudb9
rs_charset	Character set that Replication Server is using. Note The value defined for the rs_charset configuration parameter must match the RS_charset value in the Replication Server configuration file, <code>\$\$SYBASE/REP-15_5/install/<server>.cfg</code> (UNIX or Linux) or <code>%SYBASE%\REP-15_5\install\<server>.cfg</code> (Windows).	<ul style="list-style-type: none"> Windows: cp850 UNIX: iso_1
rssd_host_name	Machine where RSSD resides.	jdoe_host1
rssd_port_number	Port number where RSSD resides.	11751
rssd_database_name	Database name for RSSD.	SAMPLE_RS_ERSSD
rssd_username	Valid user for RSSD.	SAMPLE_RS_RSSD_maint
rssd_password	Password for rssd_username.	SAMPLE_RS_RSSD_maint_ps
pdb_archive_remove	Enables or disables the removal of archived IBM DB2 Universal Database transaction log files from the path specified by pdb_archive_path.	USE_DEFAULT
pdb_archive_path	Identifies directory path where Replication Agent expects to find archived IBM DB2 Universal Database transaction log files.	A valid directory path on the machine hosting Replication Agent that points to a location where IBM DB2 Universal Database puts the archived transaction log files
start_instance	Start the instance that was created.	yes
initialize_instance	Initialize the Replication Agent instance.	yes

Warning! The `rs_source_ds` and the `rs_source_db` values must match the “pds.pdb” values of your Replication Server primary connection name that you configured in step 3 in the procedure “Creating a Replication Server connection to the primary database” on page 98.

- 3 Set the IBM DB2 Universal Database environment variables by sourcing `db2cshrc`, `db2profile`, or your customized versions of the scripts as described in “Setting IBM DB2 Universal Database environment variables” on page 87.

- 4 Create and execute the new instance resource file:

- a Validate the settings in the resource file using the `-vr` parameter.

- On UNIX or Linux:

```
$SYBASE/RAX-15_5/bin/ra_admin.sh -vr myra.rs
```

- On Windows:

```
%SYBASE%\RAX-15_5\bin\ra_admin.bat -vr myra.rs
```

Here, *myra.rs* is the path and name of the resource file.

Validation results are returned as one of the following:

- Response-file processing completed
- Response-file processing completed with errors

If any validation fails, the `ra_admin` utility returns an error message and information about the failure. You can repeat the validation process as many times as necessary until it executes without error. No entities are changed or created.

- b After the resource file has been validated, allow the `ra_admin` utility to create and configure the Replication Agent instance, using the `-r` parameter.

- On UNIX or Linux:

```
$SYBASE/RAX-15_5/bin/ra_admin.sh -r myra.rs
```

- On Windows:

```
%SYBASE%\RAX-15_5\bin\ra_admin.bat -r myra.rs
```

Here, *myra.rs* is the path and name of the resource file.

Note If, in your response file, you set `start_instance` to `yes`, your instance is also running. If you set `initialize_instance` to `yes`, your instance is also initialized.

c Creation results are returned as one of the following:

- `Response-file processing completed`
- `Response-file processing completed with errors`

See the *Replication Agent Administration Guide*.

5 If, in your resource file, you set `start_instance` to `yes`, skip this step, and continue with the next section. If your resource file did not configure `start_instance` to `yes`, change to the instance directory and run Replication Agent in the background.

- On UNIX or Linux:

```
cd $SYBASE/RAX-15_5/myra
```

- On Windows:

```
cd %SYBASE%\RAX-15_5\myra
```

Execute the *RUN* file in the background.

Your Replication Agent for UDB is now running.

Verifying the Replication Agent instance

This section describes how to verify a Replication Agent instance, which involves:

- 1 Update the Replication Server *interfaces* (UNIX or Linux) or *sql.ini* (Windows) file with the Replication Agent location.
- 2 Verify the connection to the Replication Agent.
- 3 Verify the Replication Agent connection to IBM DB2 Universal Database.

❖ **Verifying the Replication Agent**

- 1 Use dsedit to update the Replication Server *interfaces* (UNIX or Linux) or *sql.ini* (Windows) file to include an entry for the Replication Agent location.

Note You can use any TDS client utility (*isql*, *isqlApp*, or *SQLAdvantage*) that you prefer.

- 2 Verify the connection to the Replication Agent:
 - a Open a command window in the *\$SYBASE* (UNIX or Linux) or *%SYBASE%* (Windows) directory of your Replication Agent installation.
 - b Set the environment variables by sourcing the *SYBASE.csh* file (UNIX or Linux) or executing the *SYBASE.bat* file (Windows).
 - c Log in to Replication Agent:

```
isql -Usa -P -Smyra
```

Note The following verification steps are optional because they were performed when you verified the resource file.

- 3 Verify the Replication Agent connection to Replication Server:

- a Enter:

```
test_connection RS
go
```

- b The following appears:

```

Type Connection
----
RS succeeded
(1 row affected)
```

- c If the result indicates a failure, either the server is not responding or the connection properties (host, port, user, or password) are incorrect.

Verify the host and port configuration values, and manually log in to the Replication Server as the configured user to determine which property is incorrectly defined.

See the *Replication Agent Administration Guide*.

- 4 Verify the Replication Agent connection to the primary IBM DB2 Universal Database:

- a Enter:

```
test_connection PDS
go
```

This message appears:

```
Type Connection
----
PDS succeeded
(1 row affected)
```

- b If the result indicates a failure:
 - The server is not responding, or
 - One of the connection properties is incorrect.

Manually log in to the primary IBM DB2 Universal Database as the configured user to find which property is incorrectly defined.

See the *Replication Agent Administration Guide* section titled, “Testing network connectivity.”

Initializing the Replication Agent instance

❖ Initializing the Replication Agent instance

Note If, in your resource file, you set `initialize_instance` to `yes`, skip this step and continue to step 2.

The `pdb_xlog init` command verifies that the primary IBM DB2 Universal Database is correctly configured to provide archived logging and that the IBM DB2 Universal Database user ID used by the Replication Agent has the necessary permissions. In addition, the `pdb_xlog init` command creates objects in the primary database to support replication.

- 1 To initialize the Replication Agent instance, run:

```
pdb_xlog init
go
```

A message appears, indicating that the procedure was successful.

- 2 Enter:

```
resume
go
```

If the Replication Agent successfully transfers to a replicating state, the following result is returned:

```
State Action
-----
REPLICATING Ready to replicate data.
```

Replication Agent returns REPLICATION DOWN state if an error occurs:

```
1> resume
2> go
Msg 32000, Level 20, State 0:
Server 'rao', Procedure 'resume', Line 1:
Command <resume> failed - Desired state <REPLICATE>
could not be achieved. Current state: <REPLICATION
DOWN>
```

- 3 The `ra_status` command returns the state of the Replication Agent. It is good practice to verify that the Replication Agent remains in replication state, even after the resume command executes successfully.

To detect an error that occurred after replication start-up, execute:

```
ra_status
go
```

If the Replication Agent is in replicating state, `ra_status` returns:

```
State Action
-----
REPLICATING Ready to replicate data.
```

Replication Agent returns REPLICATION DOWN state if an error has occurs:

```
1> ra_status
2> go
State Action
-----
REPLICATION DOWN Waiting for operator command.
```

- 4 Validate that both primary and replicate connections are active:

```
isql -Usa -P -SSAMPLE_RS
admin who
```

```
go
```

Note Be aware that:

- The DSI connection for the primary database connection is usually down because you are not replicating data back to the primary database.
 - The Replication Agent connection, if established for the replicate database connection, is usually down, because you are not replicating data from the replicate database.
-

Do not proceed until admin who has similar status for threads to the following:

```
admin who
go
```

The following appears:

```
Spid Name State Info
----
-----
13 DSI EXEC Awaiting Command 101(1)
SAMPLE_RS_ERSSD.SAMPLE_RS_ERSSD

9 DSI Awaiting Message 101
SAMPLE_RS_ERSSD.SAMPLE_RS_ERSSD

8 SQM Awaiting Message 101:0
SAMPLE_RS_ERSSD.SAMPLE_RS_ERSSD

54 DSI EXEC Awaiting Command 102(1)
DCService.rdb

53 DSI Awaiting Message 102 DCService.rdb

17 SQM Awaiting Message 102:0 DCService.rdbDSI
EXEC Suspended 103(1) NY.NYudb9

DSI Suspended 103 NY.NYudb9

24 DIST Awaiting Wakeup 103 NY.NYudb9

25 SQT Awaiting Wakeup 103:1 DIST NY.NYudb9

23 SQM Awaiting Message 103:1 NY.NYudb9
```

```
22 SQM Awaiting Message 103:0 NY.NYudb9
```

```
62 REP AGENT Awaiting Command NY.NYudb9
```

Testing replication

After you finish setting up the replication system, you can test replication.

❖ Testing replication

- 1 Connect to the primary IBM DB2 Universal Database instance as a regular user, not the maintenance user. Make sure the regular user also exists in the replicate database.

- To connect to the database with CLP, use:

```
CONNECT TO dbalias USER db2_user USING  
db2_user_ps
```

Here, *dbalias* is the cataloged alias of the primary database, *db2_user* is the primary database user, and *db2_user_ps* is the password.

- 2 Create a test table in the primary database:

```
create table T1( a int, b char(10))
```

- 3 Grant permissions to any new or existing object to be replicated in the primary database:

```
grant all on T1 to public
```

- 4 Create a test table in the replicate database:

```
create table T1( a int, b char(10))
```

- 5 Grant permissions to any new or existing object to be replicated in the replicate database, so that the Replication Server maintenance user can update this table:

```
grant all on T1 to public
```

- 6 Connect to the Replication Agent and resume replication:

```
resume
```

- 7 Run the following command to mark the table:

```
pdb_setreptable T1, mark
```

- 8 After the table is marked and the Replication Agent is in a replicating state, insert test data into the test table and commit it.

By default, the work performed by the maintenance user of the primary connection is not replicated. The user ID used to insert transactions cannot be the same as the maintenance user defined in the primary connection. See “Configuring Replication Server for replication from the primary database” on page 98.

- 9 Use your preferred IBM DB2 Universal Database query tool to examine the replicate site for results and compare the contents of your test table from both the primary and replicate sites.

Resetting the primary IBM DB2 Universal Database for replication

In a test environment, you may occasionally need to reset the replication environment. Instead of deleting and re-creating a new Replication Agent instance, use this procedure to facilitate resetting the environment.

❖ Resetting the primary database for replication

- 1 Log in to the Replication Agent and issue:

```
suspend  
go
```

- 2 Reset the locator stored in the Replication Agent:

```
ra_locator zero  
go
```

- 3 Reset the locator stored in Replication Server:

```
isql -USAMPLE_RS_RSSD_prim -PSAMPLE_RS_RSSD_prim_ps  
-SSAMPLE_RS_ERSSD -DSAMPLE_RS_ERSSD
```

```
rs_zeroltm NY, NYudb9  
go
```

This message appears:

```
Locator has been reset to zero.  
(return status = 0)
```

- 4 Resume replication:

```
resume  
go
```

Glossary

This glossary describes Replication Agent terms.

Adaptive Server

The brand name for Sybase relational database management system (RDBMS) software products.

- Adaptive Server® Enterprise manages multiple, large relational databases for high-volume online transaction processing (OLTP) systems and client applications.
- Sybase® IQ manages multiple, large relational databases with special indexing algorithms to support high-speed, high-volume business intelligence, decision support, and reporting client applications.
- SQL Anywhere (formerly Adaptive Server Anywhere) manages relational databases with a small DBMS footprint, which is ideal for embedded applications and mobile device applications.

See also **DBMS** and **RDBMS**.

atomic materialization

A materialization method that copies subscription data from a primary database to a standby database in a single, atomic operation. No changes to primary data are allowed until the subscription data is captured at the primary database. See also **bulk materialization** and **nonatomic materialization**.

BCP utility

A bulk copy transfer utility that provides the ability to load multiple rows of data into a table in a target database. See also **bulk copy**.

bulk copy

An Open Client™ interface for the high-speed transfer of data between a database table and program variables. Bulk copying provides an alternative to using SQL insert and select commands to transfer data.

bulk materialization

A materialization method whereby subscription data in a standby database is initialized outside of the replication system. You can use bulk materialization for subscriptions to table replication definitions or function replication definitions. See also **atomic materialization** and **nonatomic materialization**.

client	In client/server systems, the part of the system that sends requests to servers and processes the results of those requests. See also client application .
client application	Software that is responsible for the user interface, including menus, data entry screens, and report formats. See also client .
commit	An instruction to the DBMS to make permanent the changes requested in a transaction. See also transaction . Contrast with rollback .
data client	A client application that provides access to data by connecting to a data server. See also client , client application , and data server .
data distribution	A method of locating (or placing) discrete parts of a single set of data in multiple systems or at multiple sites. Data distribution is distinct from data replication, although a data replication system can be used to implement or support data distribution. Contrast with data replication .
data replication	The process of copying data to remote locations, and then keeping the replicated data synchronized with the primary data. Data replication is different from data distribution. Replicated data is stored copies of data at one or more remote sites throughout a system, and it is not necessarily distributed data. Contrast with data distribution . See also disk replication and transaction replication .
data server	A server that provides the functionality necessary to maintain the physical representation of a table in a database. Data servers are usually database servers, but they can also be any data repository with the interface and functionality a data client requires. See also client , client application , and data client .
database	A collection of data with a specific structure (or schema) for accepting, storing, and providing data for users. See also data server , DBMS , and RDBMS .
database connection	A connection that allows Replication Server to manage the database and distribute transactions to the database. Each database in a replication system can have only one database connection in Replication Server. See also Replication Server and route .
datatype	A keyword that identifies the characteristics of stored information on a computer. Some common datatypes are: char, int, smallint, date, time, numeric, and float. Different data servers support different datatypes.
DBMS	An abbreviation for database management system, a computer-based system for defining, creating, manipulating, controlling, managing, and using databases. The DBMS can include the user interface for using the database, or it can be a standalone data server system. Compare with RDBMS .

disaster recovery	A method or process used to restore the critical business functions interrupted by a catastrophic event. A disaster recovery (or business continuity) plan defines the resources and procedures required for an organization to recover from a disaster, based on specified recovery objectives.
ERSSD	An abbreviation for Embedded Replication Server System Database, which manages replication system information for a Replication Server. See also Replication Server .
failback	A procedure that restores the normal user and client access to a primary database, after a failover procedure switched access from the primary database to a standby database. See also failover .
failover	A procedure that switches user and client access from a primary database to a standby database, particularly in the event of a failure that interrupts operations at the primary database, or access to the primary database. Failover is an important fault-tolerance feature for systems that require high availability. See also failback .
function	A Replication Server object that represents a data server operation such as insert, delete, or begin transaction. Replication Server distributes operations to standby databases as functions. See also function string .
function string	A string that Replication Server uses to map a function and its parameters to a data server API. Function strings allow Replication Server to support heterogeneous replication, in which the primary and standby databases are different types, with different SQL extensions and different command features. See also function .
gateway	Connectivity software that allows two or more computer systems with different network architectures to communicate.
inbound queue	A stable queue managed by Replication Server to spool messages received from a Replication Agent. See also outbound queue and stable queue .
interfaces file	A file containing information that Sybase Open Client and Open Server™ applications need to establish connections to other Open Client and Open Server applications. See also Open Client and Open Server .
isql	An Interactive SQL client application that can connect and communicate with any Sybase Open Server application, including Adaptive Server, Replication Agent, and Replication Server. See also Open Client and Open Server .
Java	An object-oriented programming language developed by Sun Microsystems. A platform-independent, “write once, run anywhere” programming language.

Java VM	The Java Virtual Machine. The Java VM (or JVM) is the part of the Java Runtime Environment (JRE) that is responsible for interpreting Java byte codes. See also Java and JRE .
JDBC	An abbreviation for Java Database Connectivity. JDBC is the standard communication protocol for connectivity between Java clients and data servers. See also data server and Java .
JRE	An abbreviation for Java Runtime Environment. The JRE consists of the Java Virtual Machine (Java VM or JVM), the Java Core Classes, and supporting files. The JRE must be installed on a machine to run Java applications, such as the Replication Agent. See also Java VM .
LAN	An abbreviation for “local area network,” a computer network located on the user premises that covers a limited geographical area (usually a single site). Communication within a local area network is not subject to external regulations; however, communication across the LAN boundary can be subject to some form of regulation. Contrast with WAN .
latency	<p>In transaction replication, the time it takes to replicate a transaction from a primary database to a standby database. Specifically, latency is the time elapsed between committing an original transaction in the primary database and committing the replicated transaction in the standby database.</p> <p>In disk replication, latency is the time elapsed between a disk write operation that changes a block or page on a primary device and the disk write operation that changes the replicated block or page on a replicate device.</p> <p>See also disk replication and transaction replication.</p>
LOB	An abbreviation for large object, a type of data element that is associated with a column that contains extremely large quantities of data.
Log Reader	An internal component of the Replication Agent that interacts with the primary database to capture transactions for replication. See also Log Transfer Interface and Log Transfer Manager .
Log Transfer Interface	An internal component of the Replication Agent that interacts with Replication Server to forward transactions for distribution to a standby database. See also Log Reader and Log Transfer Manager .
Log Transfer Manager	An internal component of the Replication Agent that interacts with the other Replication Agent internal components to control and coordinate Replication Agent operations. See also Log Reader and Log Transfer Interface .

maintenance user	A special user login name in the standby database that Replication Server uses to apply replicated transactions to the database. See also Replication Server .
materialization	The process of copying the data from a primary database to a standby database, initializing the standby database so that the Replication Agent system can begin replicating transactions. See also atomic materialization , bulk materialization , and nonatomic materialization .
nonatomic materialization	A materialization method that copies subscription data without a lock on the primary database. Changes to primary data are allowed during data transfer, which may cause temporary inconsistencies between the primary and standby databases. Contrast with atomic materialization . See also bulk materialization .
ODBC	An abbreviation for Open Database Connectivity, an industry-standard communication protocol for clients connecting to data servers. See also JDBC .
Open Client	A Sybase product that provides customer applications, third-party products, and other Sybase products with the interfaces needed to communicate with Open Server applications. See also Open Server .
Open Client application	An application that uses Sybase Open Client libraries to implement Open Client communication protocols. See also Open Client and Open Server .
Open Server	A Sybase product that provides the tools and interfaces required to create a custom server. See also Open Client .
Open Server application	A server application that uses Sybase Open Server libraries to implement Open Server communication protocols. See also Open Client and Open Server .
outbound queue	A stable queue managed by Replication Server to spool messages to a standby database. See also inbound queue and stable queue .
primary data	The version of a set of data that is the source used for replication. Primary data is stored and managed by the primary database. See also Replication Agent , primary database , and Replication Server .
primary database	The database that contains the data to be replicated to another database (the standby database) through a replication system. The primary database is the database that is the source of replicated data in a replication system. Sometimes called the active database. Contrast with standby database . See also primary data .
primary key	The column or columns whose data uniquely identify each row in a table.

primary site	The location or facility at which primary data servers and primary databases are deployed to support normal business operations. Sometimes called the active site or main site. See also primary database and standby site .
primary table	A table used as a source for replication. Primary tables are defined in the primary database schema. See also primary data and primary database .
primary transaction	A transaction that is committed in the primary database and recorded in the primary database transaction log. See also primary database , replicated transaction , and transaction log .
quiesce	To cause a system to go into a state in which further data changes are not allowed. See also quiescent .
quiescent	<p>In a replication system, a state in which all updates have been propagated to their destinations. Some Replication Agent and Replication Server commands require that you first quiesce the replication system.</p> <p>In a database, a state in which all data updates are suspended so that transactions cannot change any data and the data and log devices are stable.</p> <p>This term is interchangeable with quiesced and in quiesce. See also quiesce.</p>
RASD	An abbreviation for Replication Agent System Database. Information in the RASD is used by the primary database to recognize database structure or schema objects in the transaction log.
RCL	An abbreviation for Replication Command Language, the command language used to manage Replication Server.
RDBMS	An abbreviation for relational database management system, an application that manages and controls relational databases. Compare with DBMS . See also relational database .
relational database	A collection of data in which data is viewed as being stored in tables, which consist of columns (data items) and rows (units of information). Relational databases can be accessed by SQL requests. See also SQL .
replicated data	A set of data that is replicated from a primary database to a standby database by a replication system. See also primary database , replication system , and standby database .
replicated transaction	A primary transaction that is replicated from a primary database to a standby database by a transaction replication system. See also primary database , primary transaction , standby database , and transaction replication .

Replication Agent	An application that reads a primary database transaction log to acquire information about data-changing transactions in the primary database, processes the log information, and then sends it to a Replication Server for distribution to a standby database. See also primary database and Replication Server .
replication definition	A description of a table or stored procedure in a primary database, for which subscriptions can be created. The replication definition, maintained by Replication Server, includes information about the columns to be replicated and the location of the primary table or stored procedure. See also Replication Server and subscription .
Replication Server	The Sybase software product that provides the infrastructure for a robust transaction replication system. See also Replication Agent .
RSSD	An abbreviation for Replication Server System Database, which manages replication system information for a Replication Server. See also Replication Server .
replication system	A data processing system that replicates data from one location to another. Data can be replicated between separate systems at a single site, or from one or more local systems to one or more remote systems. See also disk replication and transaction replication .
rollback	An instruction to a database to back out of the changes requested in a unit of work (called a transaction). Contrast with commit . See also transaction .
SQL	An abbreviation for Structured Query Language, a nonprocedural programming language used to process data in a relational database. ANSI SQL is an industry standard. See also transaction .
stable queue	A disk device-based, store-and-forward queue managed by Replication Server. Messages written into the stable queue remain there until they can be delivered to the appropriate process or standby database. Replication Server provides a stable queue for both incoming messages (the inbound queue) and outgoing messages (the outbound queue). See also database connection , Replication Server , and route .
standby data	The data managed by a standby database, which is the destination (or target) of a replication system. See also data replication and standby database .

standby database	A database that contains data replicated from another database (the primary database) through a replication system. The standby database is the database that receives replicated data in a replication system. Sometimes called the replicate database. Contrast with primary database . See also standby data .
standby site	The location or facility at which standby data servers and standby databases are deployed to support disaster recovery, and normal business operations during scheduled downtime at the primary site. Sometimes called the alternate site or replicate site. Contrast with primary site . See also standby database .
subscription	A request for Replication Server to maintain a replicated copy of a table, or a set of rows from a table, in a standby database at a specified location. See also replication definition and Replication Server .
table	In a relational DBMS, a two-dimensional array of data or a named data object that contains a specific number of unordered rows composed of a group of columns that are specific for the table. See also database .
transaction	A unit of work in a database that can include zero, one, or many operations (including insert, update, and delete operations), and that is either applied or rejected as a whole. Each SQL statement that modifies data can be treated as a separate transaction, if the database is so configured. See also SQL .
transaction log	Generally, the log of transactions that affect the data managed by a data server. Replication Agent reads the transaction log to identify and acquire the transactions to be replicated from the primary database. See also Replication Agent , primary database , and Replication Server .
transaction replication	A data replication method that copies data-changing operations from a primary database transaction log to a standby database. See also data replication and disk replication .
transactional consistency	A condition in which all transactions in the primary database are applied in the standby database, in the same order that they were applied in the primary database.
WAN	An abbreviation for “wide area network,” a system of local-area networks (LANs) connected together with data communication lines. Contrast with LAN .

Index

B

before you begin 2, 36, 74

C

configuring

DirectConnect server for Microsoft SQL Server 49

ECDA Option for ODBC 48, 92

Replication Agent 18, 55, 102

replication components for Microsoft SQL Server 48

Replication Server for Microsoft SQL Server 52

Replication Server for replication to standby 52

configuring Replication Server 13, 97

for replication from the primary database 13, 52, 97

for replication to standby 13, 97

creating

a DirectConnect instance 49

database replication definitions 16, 99

database replication subscriptions 17, 55, 100

Oracle user 20

Replication Agent instance 22

Replication Server connection to standby database 13, 97

Replication Server connection to standby database for Microsoft SQL Server 52

Replication Server from primary database 15, 53, 98

resource file 25, 107

D

DirectConnect server

configuring for Microsoft SQL Server 49

E

executing

resource file 25, 107

I

IBM DB2 Universal Database

installing ECDA Option for ODBC 84

installing Replication Agent 78

installing replication components 75

installing Replication Server 81

verifying the Replication Agent instance 108

identifying the Sybase installation directory 38

initializing Replication Agent instance 29, 110

installation directory

identifying 38

installation guidelines 6, 10, 46, 81, 84

for ECDA Option for ODBC 46, 84

for Replication Agent 10, 40

for Replication Server 6, 43, 81

Replication Agent for Microsoft SQL Server 40

Replication Server for Microsoft SQL Server 42

M

ma_admin utility 26, 107

Microsoft SQL Server

configuring Replication Server 52

configuring the DirectConnect server 49

creating a DirectConnect instance for 49

installing ECDA Option for ODBC 46

installing Replication Agent 40

installing replication components 37

installing Replication Server 42

system requirements 36

verifying the Replication Agent instance 64

O

Oracle

- installing Replication Agent 10
- installing Replication Server 6
- installing Replication Server Options components 3
- verifying the Replication Agent instance 27

P

- parameters for resource file 24, 105

R

replication

- components 1, 35, 73
- overview 1, 35, 73

Replication Agent

- sample resource file 23
- verifying connection to IBM DB2 Universal Database 110
- verifying connection to Oracle 28
- verifying the installation in IBM DB2 Universal Database 108
- verifying the installation in Oracle 27

replication components

- configuration 13, 48, 87

replication from the primary Microsoft SQL Server database

- configuring Replication Server 52

replication system

- diagram of 2
- diagram of Microsoft SQL Server 36
- IBM DB2 Universal Database diagram 74

resetting primary IBM DB2 Universal Database for replication

- 114

resetting primary Microsoft SQL Server database for replication

- 70

resetting primary Oracle database for replication

- 32

resource file

- creating and executing 25, 107
- parameters 24, 105

S

sample resource file

- access for Replication Agent 23
- setup prerequisites 2, 36, 74
- system requirements 2, 74
 - Microsoft SQL Server 36

T

- testing replication 31, 69, 113

U

utilities

- ma_admin 26, 107

V

verifying

- compatibility level of Microsoft SQL Server 56
- current archive setting of the redo logs 18
- primary Oracle configuration for replication 21
- Replication Agent connection to IBM DB2 Universal Database 110
- Replication Agent connection to Oracle 28
- Replication Agent instance in IBM DB2 Universal Database 108
- Replication Agent instance in Microsoft SQL Server 64
- Replication Agent instance in Oracle 27
- supplemental logging of primary key data 19