



**Performance and Tuning Guide**

---

**SAP Sybase IQ 16.0**

DOCUMENT ID: DC00169-01-1600-01

LAST REVISED: February 2013

Copyright © 2013 by Sybase, Inc. All rights reserved.

This publication pertains to Sybase software and to any subsequent release until otherwise indicated in new editions or technical notes. Information in this document is subject to change without notice. The software described herein is furnished under a license agreement, and it may be used or copied only in accordance with the terms of that agreement.

Upgrades are provided only at regularly scheduled software release dates. No part of this publication may be reproduced, transmitted, or translated in any form or by any means, electronic, mechanical, manual, optical, or otherwise, without the prior written permission of Sybase, Inc.

Sybase trademarks can be viewed at the Sybase trademarks page at <http://www.sybase.com/detail?id=1011207>. Sybase and the marks listed are trademarks of Sybase, Inc. ® indicates registration in the United States of America.

SAP and other SAP products and services mentioned herein as well as their respective logos are trademarks or registered trademarks of SAP AG in Germany and in several other countries all over the world.

Java and all Java-based marks are trademarks or registered trademarks of Oracle and/or its affiliates in the U.S. and other countries.

Unicode and the Unicode Logo are registered trademarks of Unicode, Inc.

All other company and product names mentioned may be trademarks of the respective companies with which they are associated.

Use, duplication, or disclosure by the government is subject to the restrictions set forth in subparagraph (c)(1)(ii) of DFARS 52.227-7013 for the DOD and as set forth in FAR 52.227-19(a)-(d) for civilian agencies.

Sybase, Inc., One Sybase Drive, Dublin, CA 94568.

# Contents

<b>Audience .....</b>	<b>1</b>
<b>Performance Considerations .....</b>	<b>3</b>
<b>Hardware Configuration .....</b>	<b>5</b>
Setting the Number of CPUs Available .....	5
The Process Threading Model .....	5
Network Performance .....	6
<b>Server Configuration .....</b>	<b>9</b>
Understanding Memory .....	9
Server Memory .....	9
Required Memory .....	9
Cache Memory .....	11
Large Memory .....	11
IQ Page Size .....	12
Wired Memory .....	13
Tuning Options .....	14
Optimizing for Typical Usage .....	14
Optimizing for Large Numbers of Users .....	15
Restricting Concurrent Queries .....	16
Limiting Query Temp Space .....	17
Limiting Queries by Rows Returned .....	18
Forcing Cursors to be Non-Scrolling .....	18
Limiting the Number of Cursors .....	19
Limiting the Number of Statements .....	20
Prefetching Cache Pages .....	20
Controlling the Number of Prefetched Rows .....	21
Controlling File System Buffering .....	22
Optimizing the Cache Partitions .....	23
Balancing Input/Output .....	24
Raw Devices .....	24
Disk Striping .....	24
Internal Striping .....	25

Random and Sequential File Access .....	26
Transaction and Message Logs .....	27
Monitoring Performance .....	28
Database Profiling Procedures .....	28
Event Profiling Procedures .....	30
Key Performance Indicators .....	30
Buffer Cache Performance .....	32
<b>Multiplex Performance .....</b>	<b>39</b>
Managing Multiplex Disk Space .....	39
Managing Logical Server Resources .....	39
Balancing Query Loads .....	40
<b>Schema Design .....</b>	<b>41</b>
Indexing .....	41
Indexing Tips .....	41
When and Where to use Indexes .....	42
Simple Index Selection Criteria .....	43
HG Index Loads .....	44
Multi-Column Indexes .....	45
Join Column .....	46
Primary Keys .....	47
Foreign Keys .....	47
Proper Data Type Sizing .....	48
Null Values .....	49
Unsigned Data Types .....	49
LONG VARCHAR and LONG VARBINARY .....	50
Large Object Storage .....	51
Temporary Tables .....	52
Denormalizing for Performance .....	53
UNION ALL Views for Faster Loads .....	54
Queries Referencing UNION ALL Views .....	55
UNION ALL View Performance .....	55
Hash Partitioning .....	56
<b>Troubleshooting .....</b>	<b>59</b>
Isolating Performance Problems .....	59
Diagnostic Tools .....	59

Common Performance Issues .....	60
Paging and Disk Swapping .....	60
Index and Row Fragmentation .....	61
Catalog File Growth .....	62
Thrashing and Query Execution .....	62
<b>Queries and Deletions .....</b>	<b>65</b>
Structuring Queries .....	65
Enhancing ORDER BY Query Performance .....	65
Improved Subquery Performance .....	66
Using Caching Methods .....	66
Generating Query Plans .....	66
Query Evaluation Options .....	67
Using Query Plans .....	69
Controlling Query Processing .....	69
Setting Query Time Limits .....	70
Setting Query Priority .....	70
Setting Query Optimization Options .....	71
Setting User-Supplied Condition Hints .....	71
Monitoring Workloads .....	72
Optimizing Delete Operations .....	73
HG Delete Operations .....	73
WD Delete Operations .....	74
TEXT Delete Operations .....	75
<b>Index .....</b>	<b>77</b>

# Contents

# Audience

This document is intended for database administrators, database designers, and developers who want to configure SAP® Sybase® IQ for improved performance.

Audience



# Performance Considerations

Performance is usually measured in response time and throughput. A good design and indexing strategy leads to the largest performance gains.

Response time is the time it takes for a single task to complete. Several factors affect response time:

- Reducing contention and wait times, particularly disk I/O wait times
- Using faster components
- Reducing the amount of time the resources are needed (increasing concurrency)

Throughput refers to the volume of work completed in a fixed time period. Throughput is commonly measured in transactions per second (tps), but can be measured per minute, per hour, per day, and so on.

To realize the largest performance gains run SAP Sybase IQ on a correctly configured system, establish a good design, and choose the correct indexing strategy.

Other considerations, such as hardware and network analysis, can locate bottlenecks in your installation.



# Hardware Configuration

Hardware issues that impact SAP Sybase IQ performance.

## Setting the Number of CPUs Available

---

Set the **-iqnumbercpus** startup switch to specify the number of CPUs available. This parameter overrides the physical number of CPUs for resource planning purposes.

Using the **-iqnumbercpus** switch is recommended only:

- On machines with Intel® CPUs and hyperthreading enabled, set **-iqnumbercpus** to the actual number of cores
- On machines where an operating system utility has been used to restrict SAP Sybase IQ to a subset of the CPUs within the machine

### *Additional Information*

*Administration: Database > Run Database Servers > Command Line Switches > Command Line Options for Performance > Memory Options > Number of CPUs Switch.*

## The Process Threading Model

---

SAP Sybase IQ uses operating system kernel threads for best performance. By default, SAP Sybase IQ allocates the number of threads based on the number of CPUs on the system.

Lightweight processes are underlying threads of control that are supported by the kernel. The operating system decides which lightweight processes (LWPs) should run on which processor and when. It has no knowledge about what the user threads are, but does know if they are waiting or able to run.

The operating system kernel schedules LWPs onto CPU resources. It uses their scheduling classes and priorities. Each LWP is independently dispatched by the kernel, performs independent system calls, incurs independent page faults, and runs in parallel on a multiprocessor system.

A single, highly threaded process serves all SAP Sybase IQ users. The database server assigns varying numbers of kernel threads to each user connection, based on the type of processing being done by that connection, the total number of threads available, and the various option settings.

### *Insufficient Threads Error*

If there are insufficient threads for a query, SAP Sybase IQ generates this error:

## Hardware Configuration

```
Not enough server threads available for this query
```

This condition may well be temporary. When some other query finishes, threads are made available and the query may succeed the next time. If the condition persists, you may need to restart the server and specify more SAP Sybase IQ threads. It is also possible that `-iqmt` is set too low for the number of connections.

### *SAP Sybase IQ Options for Managing Thread Usage*

- Use the server start-up option `-iqmt` to set the maximum number of threads. The default value is calculated from the number of connections and the number of CPUs and is usually adequate.
- Use the server start-up option `-iqtss` to set the stack size of the internal execution threads. The default value is generally sufficient, but may be increased if complex queries return an error indicating that the depth of the stack exceeded this limit.
- Use the `SET OPTION MAX_IQ_THREADS_PER_CONNECTION` command to set the maximum number of threads for a single user. The `SET OPTION MAX_IQ_THREADS_PER_TEAM` command sets the number of threads available to a team of threads, enabling you to constrain the number of threads (and thereby the amount of system resources) allocated to a single operation.
- Use these options to control the amount of resources a particular operation consumes. For example, you can set this option before issuing an `INSERT`, `LOAD`, `BACKUP`, or `RESTORE` command.
- Setting this option requires the `SET ANY PUBLIC OPTION` system privilege.

## Network Performance

---

Minor changes in your environment can solve some network performance issues.

To improve network throughput, provide multiple network adaptors. Classes of users can be assigned to different networks depending on service level agreements.

In case A (see the figure below) clients accessing two different database servers use one network card. That means that clients accessing Servers A and B have to compete over the network and past the network card. In the case B, clients accessing Server A use a different network card than clients accessing Server B.

It would be even better to put your database servers on different machines. You may also want to put heavy users of different databases on different machines.

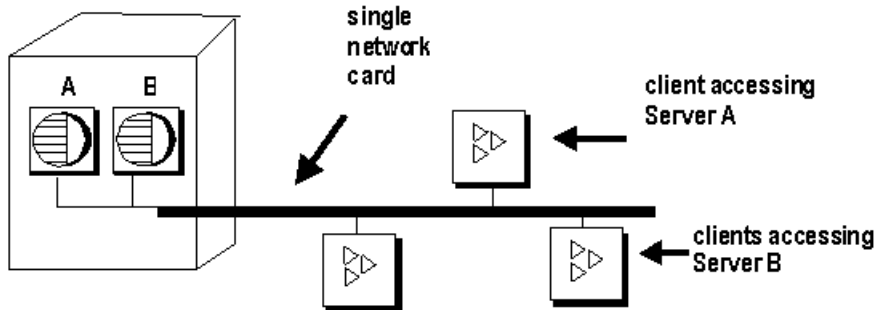
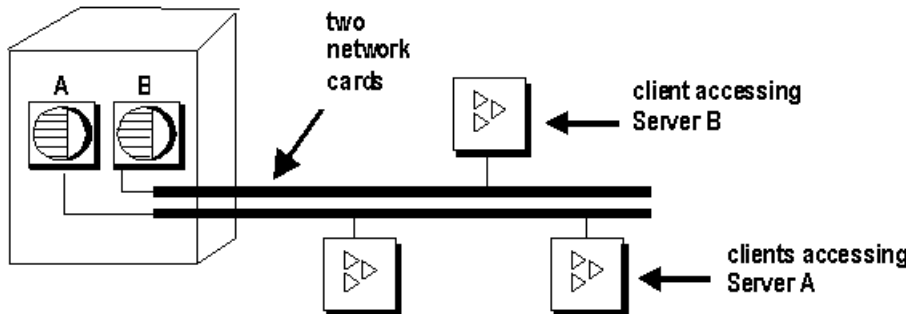
**Figure 1: Isolating heavy network users****Case A****Case B***Put Small Amounts of Data in Small Packets*

If you send small amounts of data over the network, keep the default network packet size small (default is 512 bytes). The **-p** server start-up option lets you specify a maximum packet size. Your client application may also let you set the packet size.

*Put Large Amounts of Data in Large Packets*

If most of your applications send and receive large amounts of data, increase default network packet size. This will result in fewer (but larger) transfers.

*Process at the Server Level*

Filter as much data as possible at the server level.



# Server Configuration

## Understanding Memory

---

Understanding how SAP Sybase IQ allocates memory can help you get the best performance from your system.

### Server Memory

---

SAP Sybase IQ allocates heap memory for buffers, transactions, databases, and servers. Shared memory may also be used, but in much smaller quantities.

At the operating system level, SAP Sybase IQ server memory consists of heap memory. For the most part, you do not need to be concerned with whether memory used by SAP Sybase IQ is heap memory or shared memory. All memory allocation is handled automatically. Make sure that your operating system kernel is correctly configured to use shared memory before you run SAP Sybase IQ

Most operating systems use a large percent of available memory for file system buffering. Understand the buffering policies for your operating system to avoid over-allocating memory.

The total memory used for SAP Sybase IQ main and temporary buffer caches, plus SAP Sybase IQ memory overhead, and memory used for the operating system and other applications, must not exceed the physical memory on your system.

#### See also

- *Required Memory* on page 9
- *Cache Memory* on page 11
- *Large Memory* on page 11
- *IQ Page Size* on page 12
- *Wired Memory* on page 13

### Required Memory

---

After you determine how much physical memory the operating system and other applications require, calculate how much of the remaining memory is required by SAP Sybase IQ.

#### *Raw Partitions Versus File Systems*

For UNIX-like operating systems, databases using file systems rather than raw partitions may require another 30% of the remaining memory to handle file buffering by the operating system. On Windows, file system caching should be disabled by setting `OS_FILE_CACHE_BUFFERING = 'OFF'` (the default for new databases).

### *Multiuser Database Access*

For multiuser queries of a database, SAP Sybase IQ needs about 10MB per “active” user. Active users are defined as users who simultaneously access or query the database. For example, 30 users may be connected to SAP Sybase IQ, but only 10 or so may be actively using a database at any one time.

### *Memory for Thread Stacks*

Processing threads require a small amount of memory. The more processing threads you use, the more memory needed. The **-iqmt** server switch controls the number of threads. The **-iqtss** and **-gss** server switches control the amount of stack memory allocated for each thread. The total memory allocated for IQ stacks is roughly equal to:  $(-gn * (-gss + -iqtss)) + (-iqmt * -iqtss)$ .

If you have a large number of users, the memory needed for processing threads increases. The **-gn** switch controls the number of tasks (both user and system requests) that the database server can execute concurrently. The **-gss** switch controls—in part—the stack size for server execution threads that execute these tasks. SAP Sybase IQ calculates the stack size of these worker threads using the following formula:  $(-gss + -iqtss)$ .

The total number of threads (**-iqmt** plus **-gn**) must not exceed the number allowed for your platform.

### *Other Memory Use*

All commands and transactions use some memory. The following operations are the most significant memory users in addition to those discussed previously:

- Backup. The amount of virtual memory used for backup is a function of the **IQ PAGE SIZE** specified when the database was created. It is approximately  $2 * \text{number of CPUs} * 20 * (\text{IQ PAGE SIZE}/16)$ . On some platforms you may be able to improve backup performance by adjusting **BLOCK FACTOR** in the **BACKUP** command, but increasing **BLOCK FACTOR** also increases the amount of memory used.
- Database validation and repair. When you check an entire database, the **sp\_iqcheckdb** procedure opens all tables, their respective fields, and indexes before initiating any processing. Depending on the number of tables and the cumulative number of columns and indexes in those tables, **sp\_iqcheckdb** may require very little or a large amount of virtual memory. To limit the amount of memory needed, use the **sp\_iqcheckdb** options to check or repair a single index or table.
- Dropping leaked blocks. The drop leaks operation also needs to open all tables, files, and indexes, so it uses as much virtual memory as **sp\_iqcheckdb** uses when checking an entire database. It uses the temp buffer cache to keep track of blocks used.

### **See also**

- *Server Memory* on page 9
- *Cache Memory* on page 11



- *Large Memory* on page 11
- *IQ Page Size* on page 12
- *Wired Memory* on page 13

## Cache Memory

Allocate as much memory as possible to the IQ main and temporary buffer caches for optimal performance. Change the defaults to accommodate loads, queries, and applications.

Default cache size for the main and temporary buffer caches is 64MB each. Cache size is controlled with the **-iqmc** (main cache) and **-iqtc** (temporary cache) server startup options. These startup options only remain in effect while the server is running, so you need to include them every time you restart the server.

Large memory requirements are one third of the total available physical memory allocated to SAP Sybase IQ. To ensure adequate memory for the main and temporary IQ stores, set the **-iqlm**, **-iqmc**, and **-iqtc** startup parameters so that each parameter receives one third of all available physical memory.

### **See also**

- *Server Memory* on page 9
- *Required Memory* on page 9
- *Large Memory* on page 11
- *IQ Page Size* on page 12
- *Wired Memory* on page 13

## Large Memory

The **-iqlm** startup parameter specifies the maximum amount of large memory that SAP Sybase IQ can dynamically request from the operating system.

Some load operations may require more large memory than the 2GB default provides. If memory requirements exceed the default, use the **-iqlm** startup option to increase the memory that SAP Sybase IQ can dynamically request from the OS. Set **-iqlm** as a switch as part of the command or configuration file that starts the server.

### *Large Memory Allocation*

As a general rule, large memory requirements represent one third of the total available physical memory allocated to SAP Sybase IQ. To ensure adequate memory for the main and temporary IQ stores, set the **-iqlm**, **-iqtc**, and **-iqmc** startup parameters so that each parameter receives one third of all available physical memory allocated to SAP Sybase IQ.

In most cases, you should allocate 80% of total physical memory to SAP Sybase IQ to prevent SAP Sybase IQ processes from being swapped out. Adjust actual memory allocation to accommodate other processes running on the same system. For example, on a machine with 32 cores and 128GB of total available physical memory, you would allocate 100GB

(approximately 80% of the 128GB total) to SAP Sybase IQ processes. Following the general rule, you would set the `-iqlm`, `-iqtc`, and `-iqmc` parameters to 33GB each.

### See also

- *Server Memory* on page 9
- *Required Memory* on page 9
- *Cache Memory* on page 11
- *IQ Page Size* on page 12
- *Wired Memory* on page 13

## IQ Page Size

IQ page and buffer cache size affect memory use and disk I/O throughput for the database.

SAP Sybase IQ performs I/O in units of page size. When you create a database, you specify a separate page size for the catalog store and the IQ store. The temporary store has the same page size as the IQ store.

Page size for the catalog store has no real impact on performance. The default value of 4096 bytes should be adequate. The IQ page size determines two other performance factors, the default I/O transfer block size, and the maximum data compression for your database. SAP Sybase IQ compresses all data. The amount of compression is determined by the IQ page size.

### *Saving Memory*

If your machine does not have enough memory, increase the memory and decrease the buffer cache sizes. Decreasing the buffer caches too much, however, can make your data loads or queries inefficient or incomplete due to insufficient buffers.

---

**Note:** The page size cannot be changed and determines the upper size limit on some database objects and whether LOB features can be used.

---

### See also

- *Server Memory* on page 9
- *Required Memory* on page 9
- *Cache Memory* on page 11
- *Large Memory* on page 11
- *Wired Memory* on page 13

## Wired Memory

On HP and Solaris platforms, you can designate a specified amount of memory as wired memory. Wired memory is shared memory that is locked into physical memory. The kernel cannot page this memory out of physical memory.

### *Wired Memory Pool*

On HP and Solaris platforms, you can designate a specified amount of memory as wired memory. Wired memory is shared memory that is locked into physical memory. The kernel cannot page this memory out of physical memory.

Wired memory may improve SAP Sybase IQ performance when other applications are running on the same machine at the same time. Dedicating wired memory to SAP Sybase IQ, however, makes it unavailable to other applications on the machine.

To create a pool of wired memory on these UNIX platforms only, specify the **-iqwmem** command-line switch, indicating the number of MB of wired memory. (You must be user **root** to set **-iqwmem**, except on Solaris.) On 64-bit platforms, the only upper limit on **-iqwmem** is the physical memory on the machine.

For example, on a machine with 14GB of memory, you may be able to set aside 10GB of wired memory. To do so, you specify:

```
-iqwmem 10000
```

---

**Note:** Use **-iqwmem** only if you have enough memory to dedicate the amount you specify for this purpose. Otherwise, you can cause serious performance degradation.

- On Solaris, **-iqwmem** always provides wired memory.
  - On HP, **-iqwmem** provides wired memory if you start the server as root. It provides unwired memory if you are not root when you start the server. This behavior may change in a future version.
- 

### *Impact of Other Applications and Databases*

Server memory comes out of a pool of memory used by all applications and databases. If you try to run multiple servers or multiple databases on the same machine at the same time, or if you have other applications running, you may need to reduce the amount of memory your server requests.

You can also issue the UNIX command `ipcs -mb` to see the actual number of segments.

### *Troubleshooting HP Memory Issues*

On HP-UX, check the value of the `maxdsiz_64bit` kernel parameter. This parameter restricts the amount of virtual memory available to SAP Sybase IQ on 64-bit HP processors. See the *Installation and Configuration Guide* for the recommended value.

### See also

- *Server Memory* on page 9
- *Required Memory* on page 9
- *Cache Memory* on page 11
- *Large Memory* on page 11
- *IQ Page Size* on page 12

## Tuning Options

---

Tuning options that provide faster query execution.

### Optimizing for Typical Usage

Set the `USER_RESOURCE_RESERVATION` option to adjust memory use for the number of current users.

SAP Sybase IQ tracks the number of open cursors and allocates memory accordingly. In certain circumstances, `USER_RESOURCE_RESERVATION` option can be set to adjust the minimum number of current cursors that SAP Sybase IQ thinks is currently using the product and hence allocate memory from the temporary cache more sparingly.

Set this option only if required. Contact Technical Support with details if you need to set this option.

### See also

- *Optimizing for Large Numbers of Users* on page 15
- *Restricting Concurrent Queries* on page 16
- *Limiting Query Temp Space* on page 17
- *Limiting Queries by Rows Returned* on page 18
- *Forcing Cursors to be Non-Scrolling* on page 18
- *Limiting the Number of Cursors* on page 19
- *Limiting the Number of Statements* on page 20
- *Prefetching Cache Pages* on page 20
- *Controlling the Number of Prefetched Rows* on page 21
- *Controlling File System Buffering* on page 22
- *Optimizing the Cache Partitions* on page 23

## Optimizing for Large Numbers of Users

Adjust the startup parameters for large numbers of users.

**Table 1. Sever Startup Options**

Parameter	Description
<b>-gm</b>	<p>Sets the default number of connections. Usage:</p> <pre><b>-gm</b> #_connections_to_support</pre> <p>Although this represents the total number of connections the server will support, not all connections will be active at any one time.</p>
<b>-iqgovern</b>	<p>Places a ceiling on the maximum number of queries to execute at once. If more users than the <b>-iqgovern</b> limit have submitted queries, new queries will be queued until one of the active queries is finished. Usage:</p> <pre><b>-iqgovern</b> #_ACTIVE_queries_to_support</pre> <p>The optimal value for <b>-iqgovern</b> depends on the nature of your queries, number of CPUs, and size of the buffer cache. The default value is <math>2 * numCPU + 10</math>. With a large number of connected users, you may find that setting this option to <math>2 * numCPU + 4</math> provides better throughput.</p>
<b>-gn</b>	<p>Sets the number of execution threads for the catalog store and connectivity while running with multiple users. Usage:</p> <pre><b>-gn</b> number of tasks (both user and system requests) that the database server can execute concurrently</pre> <p>The correct value for <b>-gn</b> depends on the value of <b>-gm</b>. The <b>start_iq</b> utility calculates <b>-gn</b> and sets it appropriately. Setting <b>-gn</b> too low can prevent the server from operating correctly. Setting <b>-gn</b> above 480 is not recommended.</p>
<b>-c</b>	<p>Sets the catalog store cache size. Usage:</p> <pre><b>-c</b> catalog_store_cache_size</pre> <p>The catalog cache size is highly dependent on schema size and the number of objects. The catalog store buffer cache is also the general memory pool for the catalog store. To specify in MB, use the form <b>-c nM</b>, for example, <b>-c 64M</b>.</p> <p>For up to 1000 users, set <b>-c</b> to 16MB or higher. For up to 200 users, set <b>-c</b> to 48MB (default).</p>

Parameter	Description
<b>-cl</b> and <b>-ch</b>	Set upper ( <b>-ch</b> ) and lower ( <b>-cl</b> ) limits for the catalog store cache size. <i>-cl minimum cache size -ch maximum cache size</i> . If the standard catalog cache size is too small, set <b>-cl</b> and <b>-ch</b> parameters.  Do not use <b>-c</b> in the same configuration file or command line with <b>-ch</b> or <b>-cl</b> . For related information, see the <b>-ch cache-size</b> option.
<b>-iqmt</b>	Sets the number of processing threads. If <b>-iqmt</b> is set too low for the <b>-gm</b> setting, then thread starvation can occur.

**Note:** To control catalog store cache size explicitly, you must do either of the following, but not both, in your configuration file (.cfg) or on the command line for server startup:

- Set the **-c** parameter
- Set specific upper and lower limits for the catalog store cache size using the **-ch** and **-cl** parameters

**See also**

- *Optimizing for Typical Usage* on page 14
- *Restricting Concurrent Queries* on page 16
- *Limiting Query Temp Space* on page 17
- *Limiting Queries by Rows Returned* on page 18
- *Forcing Cursors to be Non-Scrolling* on page 18
- *Limiting the Number of Cursors* on page 19
- *Limiting the Number of Statements* on page 20
- *Prefetching Cache Pages* on page 20
- *Controlling the Number of Prefetched Rows* on page 21
- *Controlling File System Buffering* on page 22
- *Optimizing the Cache Partitions* on page 23

**Restricting Concurrent Queries**

Set the **-iqgovern** switch to specify the number of concurrent queries on a particular server. This is not the same as the number of connections, which is controlled by your license.

There is an optimal value for **-iqgovern** that will provide the correct number of concurrent query access to provide optimal throughput. If **-iqgovern** is set over this threshold, contention or resource starvation occurs, slowing down all requests.

By specifying the **-iqgovern** switch, you can help SAP Sybase IQ optimize paging of buffer data out to disk, and avoid over committing memory. The default value of **-iqgovern** is (2 x the number of CPUs) + 10. You may need to experiment to find an ideal value. For sites with large numbers of active connections, try setting **-iqgovern** slightly lower.

**See also**

- *Optimizing for Typical Usage* on page 14
- *Optimizing for Large Numbers of Users* on page 15
- *Limiting Query Temp Space* on page 17
- *Limiting Queries by Rows Returned* on page 18
- *Forcing Cursors to be Non-Scrolling* on page 18
- *Limiting the Number of Cursors* on page 19
- *Limiting the Number of Statements* on page 20
- *Prefetching Cache Pages* on page 20
- *Controlling the Number of Prefetched Rows* on page 21
- *Controlling File System Buffering* on page 22
- *Optimizing the Cache Partitions* on page 23

**Limiting Query Temp Space**

Set the `QUERY_TEMP_SPACE_LIMIT` to specify the maximum estimated amount of temp space before a query is rejected.

The `QUERY_TEMP_SPACE_LIMIT` option causes queries to be rejected if their estimated temp space usage exceeds the specified size. By default, there is no limit on temporary store usage by queries.

SAP Sybase IQ estimates the temporary space needed to resolve the query. If the estimate exceeds the current `QUERY_TEMP_SPACE_LIMIT` setting, SAP Sybase IQ returns an error:

```
Query rejected because it exceeds total space resource limit
```

If this option is set to 0 (the default), there is no limit, and no queries are rejected based on their temporary space requirements.

To limit the actual temporary store usage per connection, set the `MAX_TEMP_SPACE_PER_CONNECTION` option for all DML statements, including queries. `MAX_TEMP_SPACE_PER_CONNECTION` monitors and limits the actual run time temporary store usage by the statement. If the connection exceeds the quota set by the `MAX_TEMP_SPACE_PER_CONNECTION` option, an error is returned and the current statement rolls back.

**See also**

- *Optimizing for Typical Usage* on page 14
- *Optimizing for Large Numbers of Users* on page 15
- *Restricting Concurrent Queries* on page 16
- *Limiting Queries by Rows Returned* on page 18
- *Forcing Cursors to be Non-Scrolling* on page 18
- *Limiting the Number of Cursors* on page 19
- *Limiting the Number of Statements* on page 20

- *Prefetching Cache Pages* on page 20
- *Controlling the Number of Prefetched Rows* on page 21
- *Controlling File System Buffering* on page 22
- *Optimizing the Cache Partitions* on page 23

### **Limiting Queries by Rows Returned**

Set the value of the `QUERY_ROWS_RETURNED_LIMIT` option to prevent the optimizer from rejecting queries with large result sets.

The `QUERY_ROWS_RETURNED_LIMIT` option tells the query optimizer to reject queries that might otherwise consume too many resources. If the query optimizer estimates that the result set from a query will exceed the value of this option, it rejects the query with the message:

```
Query rejected because it exceed resource: Query_Rows_Returned_Limit
```

Set this option only to reject queries that consume vast resources.

#### **See also**

- *Optimizing for Typical Usage* on page 14
- *Optimizing for Large Numbers of Users* on page 15
- *Restricting Concurrent Queries* on page 16
- *Limiting Query Temp Space* on page 17
- *Limiting Queries by Rows Returned* on page 18
- *Forcing Cursors to be Non-Scrolling* on page 18
- *Limiting the Number of Cursors* on page 19
- *Limiting the Number of Statements* on page 20
- *Prefetching Cache Pages* on page 20
- *Controlling the Number of Prefetched Rows* on page 21
- *Controlling File System Buffering* on page 22
- *Optimizing the Cache Partitions* on page 23

### **Forcing Cursors to be Non-Scrolling**

Eliminate the temporary store node in queries that return a very large result set to improve performance.

When you use scrolling cursors with no host variable declared, SAP Sybase IQ creates a temporary store node where query results are buffered. This storage is separate from the temporary store buffer cache. The temporary store node enables efficient forward and backward scrolling when your application searches through a result set.

However, if the query returns very large numbers (such as millions) of rows of output, and if your application performs mostly forward-scrolling operations, the memory requirements of



the temporary store node may degrade query performance. To improve performance, eliminate the temporary store node by issuing the following command:

```
SET TEMPORARY OPTION FORCE_NO_SCROLL_CURSORS = 'ON'
```

---

**Note:** If your application performs frequent backward-scrolling, setting the `FORCE_NO_SCROLL_CURSORS` option to `ON` may actually degrade query performance, as the absence of the temporary cache forces SAP Sybase IQ to re-execute the query for each backward scroll.

---

If your application rarely performs backward-scrolling, make

`FORCE_NO_SCROLL_CURSORS = 'ON'` a permanent `PUBLIC` option. It will use less memory and improve query performance.

### See also

- *Optimizing for Typical Usage* on page 14
- *Optimizing for Large Numbers of Users* on page 15
- *Restricting Concurrent Queries* on page 16
- *Limiting Query Temp Space* on page 17
- *Limiting Queries by Rows Returned* on page 18
- *Forcing Cursors to be Non-Scrolling* on page 18
- *Limiting the Number of Cursors* on page 19
- *Limiting the Number of Statements* on page 20
- *Prefetching Cache Pages* on page 20
- *Controlling the Number of Prefetched Rows* on page 21
- *Controlling File System Buffering* on page 22
- *Optimizing the Cache Partitions* on page 23

## Limiting the Number of Cursors

Set the `MAX_CURSOR_COUNT` option to prevent a single connection from taking too much available memory or CPU resources.

The `MAX_CURSOR_COUNT` option limits the maximum number of cursors that a connection can use at once. The default is 50. Setting this option to 0 allows an unlimited number of cursors.

### See also

- *Optimizing for Typical Usage* on page 14
- *Optimizing for Large Numbers of Users* on page 15
- *Restricting Concurrent Queries* on page 16
- *Limiting Query Temp Space* on page 17
- *Limiting Queries by Rows Returned* on page 18
- *Forcing Cursors to be Non-Scrolling* on page 18

- *Limiting the Number of Statements* on page 20
- *Prefetching Cache Pages* on page 20
- *Controlling the Number of Prefetched Rows* on page 21
- *Controlling File System Buffering* on page 22
- *Optimizing the Cache Partitions* on page 23

### **Limiting the Number of Statements**

Set the `MAX_STATEMENT_COUNT` option to limit the number of prepared statements for a connection can make.

The `MAX_STATEMENT_COUNT` option limits the maximum number of prepared statements that a connection can use at once. If a server needs to support more than the default number (50) of prepared statements at any one time for any one connection, then you can set the `MAX_STATEMENT_COUNT` option to a higher value.

#### **See also**

- *Optimizing for Typical Usage* on page 14
- *Optimizing for Large Numbers of Users* on page 15
- *Restricting Concurrent Queries* on page 16
- *Limiting Query Temp Space* on page 17
- *Limiting Queries by Rows Returned* on page 18
- *Forcing Cursors to be Non-Scrolling* on page 18
- *Limiting the Number of Cursors* on page 19
- *Prefetching Cache Pages* on page 20
- *Controlling the Number of Prefetched Rows* on page 21
- *Controlling File System Buffering* on page 22
- *Optimizing the Cache Partitions* on page 23

### **Prefetching Cache Pages**

Set the `BT_PREFETCH_MAX_MISS` option to control prefetch memory behavior.

The `BT_PREFETCH_MAX_MISS` option determines whether to continue prefetching pages for a given query. If queries using HG indexes run more slowly than expected, try gradually increasing the value of this option.

#### **See also**

- *Optimizing for Typical Usage* on page 14
- *Optimizing for Large Numbers of Users* on page 15
- *Restricting Concurrent Queries* on page 16
- *Limiting Query Temp Space* on page 17
- *Limiting Queries by Rows Returned* on page 18

- *Forcing Cursors to be Non-Scrolling* on page 18
- *Limiting the Number of Cursors* on page 19
- *Limiting the Number of Statements* on page 20
- *Controlling the Number of Prefetched Rows* on page 21
- *Controlling File System Buffering* on page 22
- *Optimizing the Cache Partitions* on page 23

## **Controlling the Number of Prefetched Rows**

Set the `PrefetchRows` and `PrefetchBuffer` parameters to improve performance on cursors under certain conditions. This is a client option that you can set on the ODBC connection dialog, or in the `.odbc.ini` file.

Prefetching improves performance on cursors that only fetch relative 1 or relative 0. Two connection parameters let you change cursor prefetch defaults. `PrefetchRows` (`PROWS`) sets the number of rows prefetched; `PrefetchBuffer` (`PBUF`) sets the memory available to this connection for storing prefetched rows. Increasing the number of rows you prefetch may improve performance under certain conditions:

- The application fetches many rows (several hundred or more) with very few absolute fetches.
- The application fetches rows at a high rate, and the client and server are on the same machine or connected by a fast network.
- Client/server communication is over a slow network, such as a dial-up link or wide area network.

### **See also**

- *Optimizing for Typical Usage* on page 14
- *Optimizing for Large Numbers of Users* on page 15
- *Restricting Concurrent Queries* on page 16
- *Limiting Query Temp Space* on page 17
- *Limiting Queries by Rows Returned* on page 18
- *Forcing Cursors to be Non-Scrolling* on page 18
- *Limiting the Number of Cursors* on page 19
- *Limiting the Number of Statements* on page 20
- *Prefetching Cache Pages* on page 20
- *Controlling File System Buffering* on page 22
- *Optimizing the Cache Partitions* on page 23

### **Controlling File System Buffering**

On some file systems, you can turn file system buffering on or off. Turning file system buffering off usually reduces paging and improves performance.

To disable file system buffering for IQ Main dbspaces of existing databases, issue the following statement:

```
SET OPTION "PUBLIC".OS_FILE_CACHE_BUFFERING = OFF
```

To disable file system buffering for IQ Temporary dbspaces of existing databases, issue the following statement:

```
SET OPTION "PUBLIC".OS_FILE_CACHE_BUFFERING_TEMPDB = OFF
```

You can only set this option for the PUBLIC role. Shut down the database and restart it for the change to take effect.

This direct I/O performance option is available on Solaris UFS, Linux, Linux IBM, AIX, and Windows file systems only. This option has no effect on HP-UX and HP-UXi and does not affect databases on raw disk. In Linux, direct I/O is supported in kernel versions 2.6.x

To enable direct I/O on Linux kernel version 2.6 and AIX, also set the environment variable `IQ_USE_DIRECTIO` to 1. Direct I/O is disabled by default in Linux kernel version 2.6 and AIX. `IQ_USE_DIRECTIO` has no effect on Solaris and Windows.

---

#### **Note:**

- SAP Sybase IQ does not support direct I/O on Linux kernel version 2.4. If you set the `IQ_USE_DIRECTIO` environment variable on Linux kernel version 2.4, the SAP Sybase IQ server does not start. The error “Error: Invalid Block I/O argument, maybe <pathname> is a directory, or it exceeds maximum file size limit for the platform, or trying to use Direct IO on unsupported OS” is reported.
- Solaris does not have a kernel parameter to constrain the size of its file system buffer cache. Over time, the file system buffer cache grows and displaces the buffer cache pages, leading to excess operating system paging activity and reduced performance. Use raw devices for databases on Solaris whenever possible.
- Windows can bias the paging algorithms to favor applications at the expense of the file system. This bias is recommended for SAP Sybase IQ performance.

---

#### **See also**

- *Optimizing for Typical Usage* on page 14
- *Optimizing for Large Numbers of Users* on page 15
- *Restricting Concurrent Queries* on page 16
- *Limiting Query Temp Space* on page 17
- *Limiting Queries by Rows Returned* on page 18

- *Forcing Cursors to be Non-Scrolling* on page 18
- *Limiting the Number of Cursors* on page 19
- *Limiting the Number of Statements* on page 20
- *Prefetching Cache Pages* on page 20
- *Controlling the Number of Prefetched Rows* on page 21
- *Optimizing the Cache Partitions* on page 23

## **Optimizing the Cache Partitions**

Changing the `CACHE_PARTITIONS` value may improve load or query performance in a multi-CPU configuration.

SAP Sybase IQ automatically calculates the number of cache partitions for the buffer cache according to the number of CPUs on your system. If load or query performance in a multi-CPU configuration is slower than expected, you may be able to improve it by changing the value of the `CACHE_PARTITIONS` database option.

As buffers approach the Least Recently Used (LRU) end of the cache, they pass a wash marker. SAP Sybase IQ writes the oldest pages—those past the wash marker—out to disk so that the cache space they occupy can be reused. A team of SAP Sybase IQ processing threads, called sweeper threads, sweeps (writes) out the oldest buffers.

When SAP Sybase IQ needs to read a page of data into the cache, it grabs the LRU buffer. If the buffer is still “dirty” (modified) it must first be written to disk. The `Gdirty` column in the monitor **-cache** report shows the number of times the LRU buffer was grabbed dirty and SAP Sybase IQ had to write it out before using it.

Usually SAP Sybase IQ is able to keep the `Gdirty` value at 0. If this value is greater than 0 for more than brief periods, you may need to adjust one of the database options that control the number of sweeper threads and the wash marker.

### *Additional Information*

- *Reference: Statements and Options > Database Options > Alphabetical List of Options > `CACHE_PARTITIONS` Option*
- *Reference: Statements and Options > Database Options > Alphabetical List of Options > `SWEeper_THREADS_PERCENT` Option*
- *Reference: Statements and Options > Database Options > Alphabetical List of Options > `WASH_AREA_BUFFERS_PERCENT` Option*

### **See also**

- *Optimizing for Typical Usage* on page 14
- *Optimizing for Large Numbers of Users* on page 15
- *Restricting Concurrent Queries* on page 16
- *Limiting Query Temp Space* on page 17
- *Limiting Queries by Rows Returned* on page 18

- *Forcing Cursors to be Non-Scrolling* on page 18
- *Limiting the Number of Cursors* on page 19
- *Limiting the Number of Statements* on page 20
- *Prefetching Cache Pages* on page 20
- *Controlling the Number of Prefetched Rows* on page 21
- *Controlling File System Buffering* on page 22

## Balancing Input/Output

---

Use disk striping, random and sequential file disk access to balance Input/Output (I/O).

### Raw Devices

On UNIX-like operating systems, you can create a database or dbspace on a raw device or a file system file.

Disk partitions are typically accessed in two modes: file system mode (for example through the UFS file system) or raw mode. Raw mode does unbuffered I/O, generally making a data transfer to or from the device with every read or write system call. UFS is the default UNIX file system, and is a buffered I/O system which collects data in a buffer until it can transfer an entire buffer at a time.

You create a database or dbspace on a raw device or a file system file. SAP Sybase IQ determines automatically from the path name you specify whether it is a raw partition or a file system file. Raw partitions can be any size.

#### See also

- *Disk Striping* on page 24
- *Internal Striping* on page 25
- *Random and Sequential File Access* on page 26
- *Transaction and Message Logs* on page 27

### Disk Striping

Striping data across multiple disks is an essential technique for good performance.

Disk striping can be performed at different places in a system, often as part of RAID hardware or software, for example:

- At the device layer, such as on a disk array or controller.
- In the operating system or dedicated device management software, such as Veritas.
- In the application.

By default, SAP Sybase IQ internally stripes pages across all files within a dbspace, so additional striping at the software or hardware level are not needed for performance. Of

course, additional striping may be necessary as part of implementing storage redundancy for the database, for example if RAID-5 is used.

Best performance in SAP Sybase IQ with storage redundancy is achieved with simple mirroring or “RAID-1”. As stated above, SAP Sybase IQ will distribute the data across all of the 2-disk mirror sets within a dbspace.

Due to cost, most SAP Sybase IQ databases will not use mirroring, and will be implemented with RAID-5 or a similar RAID level to achieve redundancy. With RAID-5, choosing an appropriate chunk size (how much data is written to one disk before moving on to the next disk) will have a significant performance impact on the system, since RAID-5 has a significant write overhead. If your application does frequent or time-sensitive loads, updates, or deletes, or if queries often do temp dbspace I/O, a smaller chunk size in the range of 25-50% of the size of a SAP Sybase IQ database page will likely give best performance. If your application is mostly reads, with little write activity, a larger chunk size 75-100% of an SAP Sybase IQ page size will likely provide best performance

Since SAP Sybase IQ normally attempts to prefetch multiple reads or flush multiple writes in parallel, even with only a single active query, using a very small chunk size to spread each page read or write across many disks will have little benefit, and will usually hurt performance.

When using RAID, best performance is usually achieved using hardware (such as controller or array) based RAID. Software based RAID tools will work well, but may add a modest additional performance load on the server’s CPUs.

### See also

- *Raw Devices* on page 24
- *Internal Striping* on page 25
- *Random and Sequential File Access* on page 26
- *Transaction and Message Logs* on page 27

## Internal Striping

Disk striping takes advantage of multiple disk spindles and provides the speed of parallel disk writes.

SAP Sybase IQ provides disk striping, options without using third-party software. If you already have a disk striping solution through third-party software and hardware, use that method instead. Disk striping can be enabled by specifying the `STRIPING ON` option to the `CREATE DBSPACE` command.

To change the default striping when creating a dbspace:

```
SET OPTION "PUBLIC".DEFAULT_DISK_STRIPING = { ON | OFF }
```

The default for the `DEFAULT_DISK_STRIPING` option is `ON` for all platforms. When disk striping is `ON`, incoming data is spread across all dbspaces with space available. When disk striping is `OFF`, dbspaces (disk segments) are filled up from the front on the logical file, filling one disk segment at a time.

Changing the value of `DEFAULT_DISK_STRIPING` affects all subsequent `CREATE DBSPACE` operations that do not specify a striping preference.

You can remove a file from a `dbspace` using the `ALTER DBSPACE DROP` command when disk striping is on. Before dropping the `dbspace`, however, you must relocate all of the data in the `dbspace` using the `sp_iqemptyfile` stored procedure. Because disk striping spreads data across multiple files, the `sp_iqemptyfile` process may require the relocation of many tables and indexes. Use the `sp_iqdbspaceinfo` and `sp_iqdbspace` stored procedures to determine which tables and indexes reside on a `dbspace`.

### See also

- *Raw Devices* on page 24
- *Disk Striping* on page 24
- *Random and Sequential File Access* on page 26
- *Transaction and Message Logs* on page 27

## Random and Sequential File Access

Performance related to randomly accessed files can be improved by increasing the number of disk drives devoted to those files, and therefore, the number of operations per second performed against those files.

Random files include those for the IQ store, the temporary store, the catalog store, programs (including the SAP Sybase IQ executables, user and stored procedures, and applications), and operating system files.

Conversely, performance related to sequentially accessed files can be improved by locating these files on dedicated disk drives, thereby eliminating contention from other processes. Sequential files include the transaction log and message log files.

To avoid disk bottlenecks:

- Keep random disk I/O away from sequential disk I/O. Also for best performance, use only one partition from a physical device (disk or HW RAID set) per `dbspace`.
- Isolate SAP Sybase IQ database I/O from I/O in other databases or other I/O intensive application.
- Place the database file, temporary `dbspace`, and transaction log file on the same physical machine as the database server.

### See also

- *Raw Devices* on page 24
- *Disk Striping* on page 24
- *Internal Striping* on page 25
- *Transaction and Message Logs* on page 27



## Transaction and Message Logs

Manage the size of the transaction and message logs to conserve disk space.

The transaction log file contains recovery and auditing information. Place the transaction log on a separate device or partition from the database itself to avoid database file fragmentation and to protect against media failure.

The transaction log can consume a large amount of disk space over time. Truncate the transaction log periodically to conserve disk space.

To truncate the log:

1. Shut down the server.
2. Start the server with the **-m** parameter as part of the **start\_iq** command or `.cfg` file.
3. Shut down and restart the server without the **-m** parameter.

Do not leave the **-m** switch permanently set. When **-m** is set, there is no protection against media failure on the device that contains the database files. Remove the **-m** from the `.cfg` after you restart the server. To move or rename the transaction log file, use the transaction log utility (**dblog**).

---

**Warning!** The SAP Sybase IQ transaction log file is different from most relational database transaction log files. If for some reason you lose your database files, then you lose your database (unless it is the log file that is lost). However, if you have an appropriate backup, then you can reload the database.

---

### *Message Log*

SAP Sybase IQ logs all messages in the message log file, including error, status, and insert notification messages. Limit the size of this file to conserve disk space.

At some sites the message log file tends to grow rapidly. To limit the size of this file:

- Set a maximum file size and archive the log files when the active message log is full
- Increase NOTIFY\_MODULUS database option setting
- Use the NOTIFY parameter to turn off notification messages in LOAD TABLE, INSERT, and CREATE INDEX statements
- Use **-iqmsgsz** switch to limit the size of the message log

### *Additional Information*

- *Utility Guide > start\_iq Database Server Startup Utility > start\_iq Server Options > -iqmsgsz iqsrv16 Server Option*
- *Utility Guide > start\_iq Database Server Startup Utility > start\_iq Server Options > -m iqsrv16 Server Option*

- *Reference: Statements and Options > Database Options > Alphabetical List of Options > NOTIFY\_MODULUS Option*
- *Reference: Statements and Options > SQL Statements > CREATE INDEX Statement*
- *Reference: Statements and Options > SQL Statements > INSERT Statement*
- *Reference: Statements and Options > SQL Statements > LOAD Statement*

.

**See also**

- *Raw Devices* on page 24
- *Disk Striping* on page 24
- *Internal Striping* on page 25
- *Random and Sequential File Access* on page 26

## Monitoring Performance

---

Tools you can use to determine whether your system is making optimal use of available resources.

### Database Profiling Procedures

---

Stored procedures that return database usage statistics.

**Table 2. Database Profiling Procedures**

Name	Description
<p><b>sp_iqconnection</b></p>	<p>Shows information about connections and versions, including which users are using temporary dbspace, which users are keeping versions alive, what the connections are doing inside SAP Sybase IQ, connection status, database version status, and so on. Usage:</p> <pre data-bbox="431 1150 861 1177">sp_iqconnection [ connhandle ]</pre> <p>See <i>Reference: Building Blocks, Tables, and Procedures &gt; System Procedures &gt; System stored procedures &gt; sp_iqconnection procedure</i></p>
<p><b>sp_iqcontext</b></p>	<p>Tracks and displays, by connection, information about statements that are currently executing. Usage:</p> <pre data-bbox="431 1341 817 1367">sp_iqcontext [ connhandle ]</pre> <p>See <i>Building Blocks, Tables, and Procedures &gt; System Procedures &gt; System stored procedures &gt; sp_iqcontext procedure</i></p>

Name	Description
<b>sp_iqcheckdb</b>	<p>Checks validity of the current database. Optionally corrects allocation problems for dbspaces or databases. Usage:</p> <pre>sp_iqcheckdb 'mode target [ ... ] [ resources resource-percent ]'</pre> <p>See <i>Building Blocks, Tables, and Procedures &gt; System Procedures &gt; System stored procedures &gt; sp_iqcheckdb procedure</i></p>
<b>sp_iqdbstatistics</b>	<p>Reports results of the most recent <b>sp_iqcheckdb</b>. Usage:</p> <pre>sp_iqdbstatistics</pre> <p>See <i>Building Blocks, Tables, and Procedures &gt; System Procedures &gt; System stored procedures &gt; sp_iqdbstatistics procedure</i></p>
<b>sp_iqdbsize</b>	<p>Displays the size of the current database. Usage:</p> <pre>sp_iqdbsize([ main ] )</pre> <p>See <i>Building Blocks, Tables, and Procedures &gt; System Procedures &gt; System stored procedures &gt; sp_iqdbsize procedure</i></p>
<b>sp_iqspaceinfo</b>	<p>Displays space usage by each object in the database. Usage:</p> <pre>sp_iqspaceinfo ['main   [table table-name   index index-name] [...] `']</pre> <p>See <i>Building Blocks, Tables, and Procedures &gt; System Procedures &gt; System stored procedures &gt; sp_iqspaceinfo procedure</i></p>
<b>sp_iqstatus</b>	<p>Displays miscellaneous status information about the database. Usage:</p> <pre>sp_iqstatus</pre> <p>See <i>Building Blocks, Tables, and Procedures &gt; System Procedures &gt; System stored procedures &gt; sp_iqstatus procedure</i></p>
<b>sp_iqtablesize</b>	<p>Displays the number of blocks used by each object in the current database and the name of the dbspace in which the object is located. Usage:</p> <pre>sp_iqtablesize ( table_owner.table_name )</pre> <p>See <i>Building Blocks, Tables, and Procedures &gt; System Procedures &gt; System stored procedures &gt; sp_iqtablesize procedure</i></p>

### See also

- *Event Profiling Procedures* on page 30
- *Key Performance Indicators* on page 30
- *Buffer Cache Performance* on page 32

## Event Profiling Procedures

Event profiling procedures return performance statistics for stored procedures, functions, events, and triggers.

**Table 3. Event Profiling Procedures**

Name	Description
<b>sa_server_option</b>	Sets database profiling options in Interactive SQL. Usage: CALL sa_server_option ( 'procedureprofiling', 'ON' )
<b>sa_procedure_profile</b>	Returns execution times for each line in database procedures, functions, events, or triggers. Usage: sa_procedure_profile [ filename [ , save_to_file ] ] )
<b>sa_procedure_profile_summary</b>	Summarizes execution times for all procedures, functions, events, or triggers. Usage: sa_procedure_profile_summary [ filename [ , save_to_file ] ] )

### Additional Information

- *SQL Anywhere Server - SQL Reference > System procedures > Alphabetical list of system procedures > sa\_server\_option system procedure.*
- *SQL Anywhere Server - SQL Reference > System procedures > Alphabetical list of system procedures > sa\_procedure\_profile system procedure.*
- *SQL Anywhere Server - SQL Reference > System procedures > Alphabetical list of system procedures > sa\_procedure\_profile\_summary system procedure.*

### See also

- *Database Profiling Procedures* on page 28
- *Key Performance Indicators* on page 30
- *Buffer Cache Performance* on page 32

## Key Performance Indicators

Set up a Statistics Collection in Sybase Control Center to monitor key performance indicators (KPI) on the server. KPI values are grouped into collections and appear in SCC monitors.

Key performance areas include SAP Sybase IQ servers, multiplex servers, and logical servers

### SAP Sybase IQ Servers Statistics

Various server status and usage statistics.

**Table 4. SAP Sybase IQ Server Statistics**

Key Performance Area	Usage Statistics
SAP Sybase IQ Availability Statistics	Resource state, CPU usage, memory allocation, cache use, and active connections.
Overview Statistics	Server status, CPU usage, memory allocation, and current active connections.
Connection Statistics	Active, available, resumed, rolled back, and suspended user and internode connections. Also displays average number of connections and disconnections per minute.
DBSpace and DBSpace File Statistics	Dbospace and dbospace file size and available percentage.
Store Input and Output Statistics	Store Input and Output Statistics identify store reads and writes per second.
Cache Statistics	Main, catalog, and temporary cache statistics.
Operations and Request Statistics	Average, minimum, maximum, and total waiting, active, and total operations.
Network Statistics	Network statistics display network activity.
Transaction Statistics	Transaction details currently on the server.

*Multiplex and Node-Related Statistics*

Multiplex and node-related statistics for multiplex servers.

**Table 5. Multiplex and Node-Related Statistics**

Key Performance Area	
Multiplex Availability	Availability statistics for each multiplex node.
Multiplex Status	Status of the multiplex.
Multiplex Node Properties	Role, status, and failover state of each multiplex node.
Multiplex Link Availability	Internode communication status between a secondary node and the coordinator.

*Logical Server Statistics*

Logical server and node-related statistics for logical servers.

**Table 6. Logical Server Statistics**

Key Performance Area	Usage Statistics
Logical Server Availability	Logical server status.
Logical Server Engine Statistics	CPU usage, connection, and connection statistics.
Logical Server Connection	Average, minimum, maximum, and total number of available connections.
Logical Server Transaction	Average, minimum, maximum, and total transactions. Also displays average and minimum number of load transactions.
Logical Server Cache Statistics	Average, minimum, and maximum cache use statistics for the catalog, temporary, and main cache.
Logical Server Operations and Requests Statistics	Average, minimum, maximum, and total waiting and active operations.

*Additional Information*

For additional information, see the Sybase Control Center for SAP Sybase IQ online help in SCC or at <http://sybooks.sybase.com/sybooks/sybooks.xhtml?prodID=10680>.

**See also**

- *Database Profiling Procedures* on page 28
- *Event Profiling Procedures* on page 30
- *Buffer Cache Performance* on page 32

**Buffer Cache Performance**

Buffer cache performance is a key factor in overall performance. The IQ UTILITIES Statement starts a cache monitor that collects buffer caches statistics. Use output from the cache monitor to fine-tune main and temp buffer cache memory allocation.

Review this checklist to isolate cache behavior that falls outside the normal range.

Table 7. Buffer Cache Monitor Checklist

Statistic	Normal behavior	Behavior that needs adjusting	Recommended action
HR% (Cache hit rate)	<p>Above 90%.</p> <p>For individual internal data structures like garray, barray, bitmap (bm), hash object, sort object, variable-length btree (btreev), fixed-length btree (btreef), bit vector (bv), dbext, dbid, vdo, store, checkpoint block (ckpt), the hit rate should be above 90% while a query runs. It may be below 90% at first. Once prefetch starts working (PF or PrefetchReqs &gt; 0), the hit rate should gradually grow to above 90%.</p>	<p>Hit rate below 90% after prefetch is working.</p> <hr/> <p><b>Note:</b> Some objects do not do prefetching, so their hit rate may be low normally.</p> <hr/>	<p>Try rebalancing the cache sizes of main versus temp by adjusting <code>-iqmc</code> and <code>-iqtc</code>.</p> <p>Also try increasing the number of prefetch threads by adjusting <code>PRE-FETCH_THREADS_PERCENT</code> option.</p>
Gdirty (Grabbed Dirty)	<p>0 in a system with a modest cache size (&lt; 10GB).</p>	<p>GDirty &gt; 0</p> <hr/> <p><b>Note:</b> Sweeper threads are activated only when the number of dirty pages reaches a certain percentage of the wash area. If GDirty/GrabbedDirty is above 0 and the I/O rate (Writes) is low, the system may simply be lightly loaded, and no action is necessary.</p> <hr/>	<p>Adjust <code>SWEEP-ER_THREADS_PERCENT</code> option (default 10%) or <code>WASH_AREA_BUFFERS_PERCENT</code> option (default 20%) to increase the size of the wash area.</p>

Statistic	Normal behavior	Behavior that needs adjusting	Recommended action
BWaits (Buffer Busy Waits)	0	Persistently > 0, indicating that multiple jobs are colliding over the same buffers.	<p>If the I/O rate (Writes) is high, Busy Waits may be caused by cache thrashing. Check Hit Rate in the cache report to see if you need to rebalance main versus temp cache.</p> <p>If a batch job is starting a number of nearly identical queries at the same time, try staggering the start times.</p>
LRU Waits (LRUNum TimeOuts percentage in debug report)	20% or less	> 20%, which indicates a serious contention problem.	Check the operating system patch level and other environment settings. This problem tends to be an O.S. issue.
IOWait (IONumWaits)	10% or lower	> 10%	Check for disk errors or I/O retries
FLWait (FLMutex-Waits)	20% or lower	> 20%	<p>Check the dbspace configuration:</p> <p>Is the database almost out of space?</p> <p>Is DISK_STRIPING ON?</p> <p>Does <b>sp_iqcheckdb</b> report fragmentation greater than 15%?</p>



Statistic	Normal behavior	Behavior that needs adjusting	Recommended action
HTWait (BmapHT- NumWaits)  MemWts (MemNti- mesWaited)  (PFMgrCond VarWaits)	10% or lower	> 10%	Contact Sybase Technical Support.
CPU time (CPU Sys Seconds, CPU Total Seconds, in debug report)	CPU Sys Seconds < 20%	CPU Sys Seconds > 20%  If CPU Total Seconds also reports LOW utilization, and there are enough jobs that the system is busy, the cache may be thrashing or parallelism may be lost.	Adjust <b>-iqgovern</b> to reduce allowed total number of concurrent queries.  Check Hit Rate and I/O Rates in the cache report for cache thrashing. Also check if hash object is thrashing by looking at the hit rate of the has object in cache_by_type (or debug) report: is it <90% while the I/O rate (Writes) is high?  Check query plans for attempted parallelism. Were enough threads available?  Does the system have a very large number of CPUs? Strategies such as multiplex configuration may be necessary.

Statistic	Normal behavior	Behavior that needs adjusting	Recommended action
InUse% (Buffers in use)	At or near 100% except during startup	Less than about 100%	The buffer cache may be too large.  Try rebalancing the cache sizes of main versus temp by adjusting <b>-iqmc</b> and <b>-iqtc</b> .
Pin% (Pinned buffers)	< 90%	> 90 to 95%, indicating system is dangerously close to an Out of Buffers condition, which would cause transactions to roll back	Try rebalancing the cache sizes of main versus temp.  If rebalancing buffer cache sizes is not possible, try reducing <b>-iqgovern</b> to limit the number of jobs running concurrently.
Free threads (ThrNum-Free)	Free > Resrvd	If the number of free threads drops to the reserved count, the system may be thread starved.	Try one of the following:  Increase the number of threads by setting <b>-iqmt</b> .  Reduce thread-related options: MAX_IQ_THREADS_PER_CONNECTION, MAX_IQ_THREADS_PER_TEAM.  Restrict query engine resource allocations by setting <b>USER_RESOURCE_RESERVATION</b> .  Limit the number of jobs by setting <b>-iqgovern</b> .

Statistic	Normal behavior	Behavior that needs adjusting	Recommended action
FlOutOfSpace (debug only)	0, indicating that the free list for this store is not full; unallocated pages are available	1, indicating that this store (main or temporary) is fully allocated	Add more dbspace to that store

---

**Note:** If one cache performs significantly more I/O than the other, reallocate some of the memory in small amounts, such as 10 percent of the cache allocation on an iterative basis. After reallocating, rerun the workload and monitor the performance changes.

---

#### *Additional Information*

*Reference: Statements and Options > SQL Statements > IQ UTILITIES Statement*

#### **See also**

- *Database Profiling Procedures* on page 28
- *Event Profiling Procedures* on page 30
- *Key Performance Indicators* on page 30



# Multiplex Performance

Adjust your system for maximum performance or better use of disk space.

Each server in the multiplex can be on its own host or share a host with other servers. Two or more servers on the same system consume no more CPU time than a single combined server handling the same workload, but separate servers might need more physical memory than a single combined server, because the memory used by each server is not shared by any other server.

## Managing Multiplex Disk Space

---

Get users to commit their current transactions periodically, and allow the write server to drop old table versions to free disk blocks. Specifying the `auto_commit` option helps minimize space due to minimize version buildup.

SAP Sybase IQ cannot drop old versions of tables while any user on any server might be in a transaction that might need the old versions. SAP Sybase IQ may therefore consume a very large amount of disk space when table updates and queries occur simultaneously in a multiplex database. The amount of space consumed depends on the nature of the data and indexes and the update rate.

You can free disk blocks by allowing the write server to drop obsolete versions no longer required by queries. All users on all servers should commit their current transactions periodically to allow recovery of old table versions. The servers may stay up and are fully available. The `sp_iqversionuse` stored procedure can be used to display version usage for remote servers.

## Managing Logical Server Resources

---

Logical servers let you to manage the use of multiplex resources most effectively. Use logical servers to assign different sets of multiplex servers to different applications to meet their individual performance requirements.

In a multiplex, each connection operates under a single logical server context. When you submit a query to a multiplex server, its execution may be distributed to one or more multiplex servers, depending upon the configuration of the connection's logical server. To dynamically adjust the resources assigned to a logical server, add or remove multiplex servers from the logical server to meet the changing needs of the applications that it serves.

## Balancing Query Loads

---

Using the SAP Sybase IQ network client to balance the query load among multiplex query servers requires an intermediate system that is able to dispatch the client connection to a machine in a pool.

To use this method, on the client system you create a special ODBC DSN, with the IP address and port number of this intermediate load balancing system, a generic server name, and the **VerifyServerName** connection parameter set to **NO**. When a client connects using this DSN, the load balancer establishes the connection to the machine it determines is least loaded.

---

**Note:** Third-party software is required. **VerifyServerName** simply allows this method to work.

---

### *Additional Information*

*Administration: Database > Appendix: Connection and Communication Parameters*

*Reference > Network Communications Parameters > VerifyServerName Communication Parameter [Verify]*

# Schema Design

Good database performance begins with good database design. Take the time to incorporate design features into your schema during development for better response time and faster query results.

## Indexing

---

Indexing selection and solutions for SAP Sybase IQ.

### See also

- *Join Column* on page 46
- *Primary Keys* on page 47
- *Foreign Keys* on page 47
- *Proper Data Type Sizing* on page 48
- *Null Values* on page 49
- *Unsigned Data Types* on page 49
- *LONG VARCHAR and LONG VARBINARY* on page 50
- *Large Object Storage* on page 51
- *Temporary Tables* on page 52
- *Denormalizing for Performance* on page 53
- *UNION ALL Views for Faster Loads* on page 54
- *Hash Partitioning* on page 56

## Indexing Tips

Choose the correct column index type to make your queries run faster.

SAP Sybase IQ provides some indexes automatically—an index on all columns that optimizes projections, and an HG index for UNIQUE and PRIMARY KEYS and FOREIGN KEYS. While these indexes are useful for some purposes, you may need other indexes to process certain queries as quickly as possible.

### INDEX\_ADVISOR

INDEX\_ADVISOR generates messages when the optimizer would benefit from an additional index on one or more columns in your query.

To activate the index advisor, set the INDEX\_ADVISOR option ON. Messages print as part of a query plan or as a separate message in the message log (.iqmsg) if query plans are not enabled, and output is in OWNER.TABLE.COLUMN format.

### *LF or HG Indexes*

Consider creating either an LF or HG index on grouping columns referenced by the WHERE clause in a join query if the columns are not using enumerated FP storage. The optimizer may need metadata from the enumerated FP or HG/LF index to produce an optimal query plan. Non-aggregated columns referenced in the HAVING clause may also benefit from a LF or HG index to help with query optimization. For example:

```
SELECT c.name, SUM(l.price * (1 - l.discount))
FROM customer c, orders o, lineitem l
WHERE c.custkey = o.custkey
      AND o.orderkey = l.orderkey
      AND o.orderdate >= "1994-01-01"
      AND o.orderdate < "1995-01-01"
GROUP by c.name
HAVING c.name NOT LIKE "I%"
      AND SUM(l.price * (1 - l.discount)) > 0.50
ORDER BY 2 desc
```

Adding indexes increases storage requirements and load time. Add indexes only if there is a net benefit to query performance.

### *Additional Information*

*Reference: Statements and Options > Database Options > Alphabetical List of Options > INDEX\_ADVISOR Option*

### **See also**

- *When and Where to use Indexes* on page 42
- *Simple Index Selection Criteria* on page 43
- *HG Index Loads* on page 44
- *Multi-Column Indexes* on page 45

## **When and Where to use Indexes**

Indexes are the primary tuning mechanisms inside SAP Sybase IQ. Knowing when and where to use indexes can make your queries run faster.

Always use indexes on:

- Join columns (HG index regardless of cardinality)
- Searchable columns (HG or LF index based on cardinality)
- DATE, TIME, and DATETIME/TIMESTAMP columns (DATE, TIME, DTTM)

The DATE, TIME, or DATETIME/TIMESTAMP column should also have an LF or HG index depending on data cardinality.

- If you are uncertain whether the column will be used heavily, place an LF or HG index on the column. Workload Management can subsequently be enabled to monitor the use of indexes.



- Use `PRIMARY KEY`, `UNIQUE CONSTRAINT`, or `UNIQUE` HG indexes where appropriate, as they provide SAP Sybase IQ with additional information about the unique data in the indexed column(s).
- A column with an `HNG` or `CMP` index should have a corresponding `LF` or `HG` index
- Indexes are not needed on columns whose data is `ONLY` returned to the client (projected)

### See also

- *Indexing Tips* on page 41
- *Simple Index Selection Criteria* on page 43
- *HG Index Loads* on page 44
- *Multi-Column Indexes* on page 45

## Simple Index Selection Criteria

Answers to some simple questions can help you choose the right index for a column.

To determine the best indexes for your datamodel without regard for queries, ask yourself these simple questions about each column:

- Is the cardinality greater than 1500-2000?  
If the answer is yes, place an `HG` index on this column. If not, place an `LF` index on the column.
- Does the column contain `DATE`, `TIME`, `DATETIME`, or `TIMESTAMP` data?  
If the answer is yes, place a `DATE`, `TIME`, or `DTTM` index on this column. You should also place an `LF` or `HG` on the column.
- Will the column be used in range searches or aggregations?  
If the answer is yes, place an `HNG` index on the column. You should also place an `LF` or `HG` should be on the column. If the aggregation contains more than just the column, an `HNG` may not be appropriate. In most cases an `HNG` index is not needed as the `LF` or `HG` indexes have more than enough capability to perform the aggregations. This does not apply to `DATE`, `TIME`, or `DATETIME` types.
- Will this column be used for word searching?  
If the answer is yes, place a `WD` index on the column. An `LF` or `HG` index is not necessary and would consume significant space.
- Will this column be used for full text searching?  
If the answer is yes, place a `TEXT` index on the column. An `LF` or `HG` is not necessary and would consume significant space.
- Will two columns in the same table be compared to each other (`A = B`, `A < B`, `A > B`, `A <= B`, `A >= B`)?  
If the answer is yes, place a `CMP` index on the two columns.
- Will this column, or set of columns, be used in `GROUP BY` or `ORDER BY` statements?

If the answer is yes, place an HG index on the column, or columns in the `GROUP BY` or `ORDER BY` statement. Each column should also have a corresponding HG or LF index.

- Is this column part of a multicolumn primary key, constraint, or index?

If the answer is yes, place an HG or LF index on each column in the multicolumn index.

### See also

- *Indexing Tips* on page 41
- *When and Where to use Indexes* on page 42
- *HG Index Loads* on page 44
- *Multi-Column Indexes* on page 45

## HG Index Loads

Relative to other indexes, the HG indexes are more expensive to maintain during data loads and deletions. A main contributor to the performance of the HG index is the location of the data within the HG index structure: the sparsity or density of the operation.

Dense HG operations are those in which the affected rows are tightly grouped around certain keys. Sparse operations are those where there may be just a few rows per key that must be affected. For instance, dates on data are typically grouped around the time the operation was logged, data modified, etc. This means that new data will be placed at the end of the HG index structure. When deleting data in the date HG index, said data would typically come off in chunks of days, weeks, months, etc and thus be removed from the beginning of the HG btree or be tightly grouped around a few keys for deletion. These operations are very fast, relatively speaking, as SAP Sybase IQ will operate on a few pages and affect a tremendous number of rows.

Data that is rather sparse, like Prices, Customer IDs, City, Country, etc., are very different. As "pricing" data, for instance, is loaded each value will vary widely across all data already in the index. If the column is tracking stock prices the numeric field to store that data will be densely updated because the data being changed will be across the nearly the entire range of values already loaded. These operations are slower due to the amount of index pages that must be maintained for each row being affected. A worst case scenario is that SAP Sybase IQ is forced to read and write 1 page for EACH ROW being loaded or deleted. While this can be less than optimal, SAP Sybase IQ has been design to parallel process phase 2 of the HG index loads and the deletes so that the impact is greatly reduced.

All of this is well and good, but how does it affect the data model design and indexing? Typical tuning and optimization within SAP Sybase IQ generally boils down to indexes or the lack thereof. Knowing how the indexes can be affected by the data and loading is an important aspect when deciding which indexes to put in place and which to leave off. Because HG indexes take, relatively, more time to load than other indexes they are often the subject of focus when it comes to use and design. Certainly, HG indexes can help with query performance. There are times, though, where adding an index may have a slight positive impact on queries

but have more of an impact to data loads. In these situations, it is important to understand why the load or delete took longer and what can be done about it.

The sparsity or density of new data with respect to currently loaded data plays a critical role in this. If a relatively random column of a Customer ID must be indexed for fast query performance and an index must be on that column. Suppose, though, that a primary key exists on the table and it is the Customer ID and a Date field storing a transaction datetime. If the ordering were left as `(customer_id, transaction_date)` the data would be sparsely loaded or deleted from the table in most case. Data being loaded will be done so by transaction date. Since the Customer ID column is first in the multicolumn index, though, it will force SAP Sybase IQ to touch data throughout the entire HG index structure.

A simple change in order to `(transaction_date, customer_id)` changes this behavior. The index is still in place to control referential integrity for the primary key. The ordering of the columns is immaterial for primary key enforcement. As such, we can change the column order without causing any downstream ill effects. This simple change will now force all new data being loaded by transaction date to be inserted at the end of the HG index structure in a very dense manner. Over time the loads will perform consistently as the data is, generally, always going to the end of the HG structure.

Simply changing the column ordering in a multicolumn index can have drastic impacts on performance. The size of the HG index shouldn't change much as the data is still the same width regardless of order. What will change is how fast the data is loaded or deleted from the table.

### See also

- *Indexing Tips* on page 41
- *When and Where to use Indexes* on page 42
- *Simple Index Selection Criteria* on page 43
- *Multi-Column Indexes* on page 45

## Multi-Column Indexes

Currently, only HG, UNIQUE HG, UNIQUE CONSTRAINT, and PRIMARY KEY indexes support multiple columns in index creation, but multi-column indexes are also useful for GROUP BY and ORDER BY statements.

From a statistics point of view, multi-column indexes provide enough information in multi-column table joins to let the optimizer know the exact statistics of the join and whether or not it is a many-to-many or one-to-many join. The optimizer is also smart enough to use the statistics for optimization, but use individual HG/LF indexes for the actual work. The optimizer costs out all join and sort scenarios and decides which index(es) is best for that operation. The statistics help it get to that point.

Some items to keep in mind about the HG indexes:

- HG inserts are the most expensive

## Schema Design

- Try to guarantee that inserts will happen at the end of the index

Place generally incrementing data, like a transaction date or batch number (sequential data), at the beginning of the index list. Something that will try to guarantee a sequential key.

### See also

- *Indexing Tips* on page 41
- *When and Where to use Indexes* on page 42
- *Simple Index Selection Criteria* on page 43
- *HG Index Loads* on page 44

## Join Column

---

For joins, keep the data types as narrow as possible to reduce disk I/O and memory requirements.

Because integer comparisons are quicker than character comparisons, use integer data types (unsigned if possible) in joins. Keeping the data types as narrow as possible improves join performance by reducing disk I/O and memory requirements. Because the HG index has slightly more capability from a join perspective, use an HG index on join columns rather than a cardinality appropriate index (LF or HG) . This should be weighed against the potential increase in time to load the HG index as compared to the LF index.

### See also

- *Indexing* on page 41
- *Primary Keys* on page 47
- *Foreign Keys* on page 47
- *Proper Data Type Sizing* on page 48
- *Null Values* on page 49
- *Unsigned Data Types* on page 49
- *LONG VARCHAR and LONG VARBINARY* on page 50
- *Large Object Storage* on page 51
- *Temporary Tables* on page 52
- *Denormalizing for Performance* on page 53
- *UNION ALL Views for Faster Loads* on page 54
- *Hash Partitioning* on page 56

## Primary Keys

---

Multi-column primary keys should have an additional LF or HG index placed on each column specified in the primary key. This must be done manually as SAP Sybase IQ only creates an HG index on the composite columns.

UNIQUE constraint, UNIQUE HG, and primary key share an identical structure. That structure uses an HG index with no G-Array to store the row ids. When possible, use primary keys on tables. This helps the optimizer make more informed query path decisions even if the index is not used. The index structure provides detailed statistics to help the optimizer make better choices as well as providing a structure to traverse the data.

### See also

- *Indexing* on page 41
- *Join Column* on page 46
- *Foreign Keys* on page 47
- *Proper Data Type Sizing* on page 48
- *Null Values* on page 49
- *Unsigned Data Types* on page 49
- *LONG VARCHAR and LONG VARBINARY* on page 50
- *Large Object Storage* on page 51
- *Temporary Tables* on page 52
- *Denormalizing for Performance* on page 53
- *UNION ALL Views for Faster Loads* on page 54
- *Hash Partitioning* on page 56

## Foreign Keys

---

As with primary keys, use foreign keys to improve query join performance. This gives SAP Sybase IQ one more piece of information on how tables are joined and the statistics behind those joins. SAP Sybase IQ automatically creates an HG Index on the foreign key column, so no additional HG or LF index is necessary. A foreign key requires that a primary key exists on referenced table.

### See also

- *Indexing* on page 41
- *Join Column* on page 46
- *Primary Keys* on page 47

- *Proper Data Type Sizing* on page 48
- *Null Values* on page 49
- *Unsigned Data Types* on page 49
- *LONG VARCHAR and LONG VARBINARY* on page 50
- *Large Object Storage* on page 51
- *Temporary Tables* on page 52
- *Denormalizing for Performance* on page 53
- *UNION ALL Views for Faster Loads* on page 54
- *Hash Partitioning* on page 56

## Proper Data Type Sizing

---

Size all data types as accurately as possible, especially character-based data types.

To decide which data type to use for a column, consider these factors:

- SAP Sybase IQ includes a large number of data types. Using the correct data types for your application leads to optimal performance gains.
- If HOUR, MINUTE and SECOND information is not necessary, use DATE instead of DATETIME
- If the data will fit within a TINYINT or SMALLINT datatype use that rather than INTEGER or BIGINT
- Do not over allocate storage when defining NUMERIC () or DECIMAL () as it can be costly for data that does not need all that level of precision
- CHAR () and VARCHAR() types are fixed width in the default Flat FP index. The only difference is the addition of 1 byte to each VARCHAR() row that represents the number of bytes in use.

SAP Sybase IQ includes compression algorithms that compress large repeating patterns often seen in BINARY (), CHAR (), VARCHAR (), and VARBINARY () data types.

### See also

- *Indexing* on page 41
- *Join Column* on page 46
- *Primary Keys* on page 47
- *Foreign Keys* on page 47
- *Null Values* on page 49
- *Unsigned Data Types* on page 49
- *LONG VARCHAR and LONG VARBINARY* on page 50
- *Large Object Storage* on page 51
- *Temporary Tables* on page 52

- *Denormalizing for Performance* on page 53
- *UNION ALL Views for Faster Loads* on page 54
- *Hash Partitioning* on page 56

## Null Values

---

Defining columns as `NULL` or `NOT NULL` helps the optimizer work more efficiently.

Specifying `NULL` or `NOT NULL` allows the optimizer a more educated guess at joins and search criteria by having one more piece of information about the characteristics of the data. `NULL` data does not save space on the database page, as it would in other databases. `NULL` data will, however, be compressed out when stored on disk due to the SAP Sybase IQ compression algorithms and optimized indexes.

- Always specify `NULL` or `NOT NULL`
- Open Client and ODBC connections have different default behavior when table is created
- Give the optimizer an additional piece of information about the characteristics of the data for joins and search arguments

### See also

- *Indexing* on page 41
- *Join Column* on page 46
- *Primary Keys* on page 47
- *Foreign Keys* on page 47
- *Proper Data Type Sizing* on page 48
- *Unsigned Data Types* on page 49
- *LONG VARCHAR and LONG VARBINARY* on page 50
- *Large Object Storage* on page 51
- *Temporary Tables* on page 52
- *Denormalizing for Performance* on page 53
- *UNION ALL Views for Faster Loads* on page 54
- *Hash Partitioning* on page 56

## Unsigned Data Types

---

In some cases, using unsigned data types can eliminate sign comparisons and create faster queries.

Use unsigned data types when the sign of the data does not matter as all data will always be greater than or equal to zero. The lack of sign storage results in column comparisons that no

longer have to perform sign comparison. This increases performance and eliminates a step in the joining and searching of data, particularly for key columns.

### See also

- *Indexing* on page 41
- *Join Column* on page 46
- *Primary Keys* on page 47
- *Foreign Keys* on page 47
- *Proper Data Type Sizing* on page 48
- *Null Values* on page 49
- *LONG VARCHAR and LONG VARBINARY* on page 50
- *Large Object Storage* on page 51
- *Temporary Tables* on page 52
- *Denormalizing for Performance* on page 53
- *UNION ALL Views for Faster Loads* on page 54
- *Hash Partitioning* on page 56

## LONG VARCHAR and LONG VARBINARY

---

Use `VARCHAR ()` and `VARBINARY ()` to increase column storage without using large object storage mechanisms.

Typically, developers and DBAs think of `VARBINARY ()` and `VARCHAR ()` data as being limited to 255 bytes. SAP Sybase IQ supports `VARCHAR ()` and `VARBINARY ()` widths of up to 32K (also known as `LONG VARCHAR` or `LONG VARBINARY`). This allows for much larger storage of text or binary data without needing to move into the highly specialized large objects storage mechanism of `BLOB/CLOB` or `IMAGE/TEXT` data types.

- Can be used to store moderate amounts of text or binary data
- Maximum width is 32K (64K ASCII hex for `VARBINARY ()`)
- The `WORD` and `TEXT` index is the only index allowed on `VARCHAR ()` data wider than 255 bytes
- Storage will be allocated in 256 byte chunks
- A 257 byte string will require 512 bytes of storage
- A 511 byte string will also require 512 bytes of storage

### See also

- *Indexing* on page 41
- *Join Column* on page 46
- *Primary Keys* on page 47
- *Foreign Keys* on page 47



- *Proper Data Type Sizing* on page 48
- *Null Values* on page 49
- *Unsigned Data Types* on page 49
- *Large Object Storage* on page 51
- *Temporary Tables* on page 52
- *Denormalizing for Performance* on page 53
- *UNION ALL Views for Faster Loads* on page 54
- *Hash Partitioning* on page 56

## Large Object Storage

---

Use Large Object data types for data that requires more than 32K in storage.

- Large object data types store ASCII (`TEXT/CLOB`) and binary (`IMAGE/BLOB`) data. Each `BLOB/CLOB` cell of data is stored on one or more pages:
  - Assuming the page size is 128K
  - If the data is 129K, it will require 2 pages to store the information
  - If the data is 1K, it will require 1 page to store the data
  - In either case, the page(s) are compressed on disk into multiples of the block size
- Can be used to store binary or text based objects
- Extends the long binary data type from a maximum size of 6K to an unlimited size
- The `TEXT` index is the only viable index
- Can be fully searched with the `TEXT` index and its search capabilities
- Special function to return the size of an object (`byte_length64`)
- Special function to return portions of the object, not the entire contents (`byte_substr64`)
- Can extract contents of a binary object cell to an individual file with the `BFILE()` function

### See also

- *Indexing* on page 41
- *Join Column* on page 46
- *Primary Keys* on page 47
- *Foreign Keys* on page 47
- *Proper Data Type Sizing* on page 48
- *Null Values* on page 49
- *Unsigned Data Types* on page 49
- *LONG VARCHAR and LONG VARBINARY* on page 50
- *Temporary Tables* on page 52
- *Denormalizing for Performance* on page 53

- *UNION ALL Views for Faster Loads* on page 54
- *Hash Partitioning* on page 56

## Temporary Tables

---

If you want the data to persist through transaction commits, use the `ON COMMIT PRESERVE ROWS` option when you create global temporary tables or declare local temporary tables.

There are three types of Temporary Tables:

- # tables

```
CREATE TABLE #temp_table ( col1 int )
```

- Local Temporary Tables

```
DECLARE LOCAL TEMPORARY TABLE temp_table ( col1 int )
```

Local Temporary Tables behave just like # tables

- Global Temporary Tables

```
CREATE GLOBAL TEMPORARY TABLE temp_table ( col1 int )
```

Global Temporary Table structure is static across connections and reboots

Normal hash (#) tables do not need the `ON COMMIT PRESERVE ROWS` option because the data in a hash table will always persist through transaction commits.

### See also

- *Indexing* on page 41
- *Join Column* on page 46
- *Primary Keys* on page 47
- *Foreign Keys* on page 47
- *Proper Data Type Sizing* on page 48
- *Null Values* on page 49
- *Unsigned Data Types* on page 49
- *LONG VARCHAR and LONG VARBINARY* on page 50
- *Large Object Storage* on page 51
- *Denormalizing for Performance* on page 53
- *UNION ALL Views for Faster Loads* on page 54
- *Hash Partitioning* on page 56

## Denormalizing for Performance

---

Denormalizing your database can improve performance, but there are risks and disadvantages.

Denormalization can be successfully performed only with thorough knowledge of the application and should be performed only if performance issues indicate that it is needed. Consider the effort required to keep your data up-to-date.

This is a good example of the differences between decision support applications, which frequently need summaries of large amounts of data, and transaction processing needs, which perform discrete data modifications. Denormalization usually favors some processing, at a cost to others.

Denormalization has the potential for data integrity problems, which must be carefully documented and addressed in application design.

### *Deciding to Denormalize*

Analyze the data access requirements of the applications in your environment and their actual performance characteristics, including:

- What are the critical queries, and what is the expected response time?
- What tables or columns do they use? How many rows per access?
- What is the usual sort order?
- What are concurrency expectations?
- How big are the most frequently accessed tables?
- Do any processes compute summaries?

### **See also**

- *Indexing* on page 41
- *Join Column* on page 46
- *Primary Keys* on page 47
- *Foreign Keys* on page 47
- *Proper Data Type Sizing* on page 48
- *Null Values* on page 49
- *Unsigned Data Types* on page 49
- *LONG VARCHAR and LONG VARBINARY* on page 50
- *Large Object Storage* on page 51
- *Temporary Tables* on page 52
- *UNION ALL Views for Faster Loads* on page 54
- *Hash Partitioning* on page 56

## UNION ALL Views for Faster Loads

---

UNION ALL views can improve load performance when it is too expensive to maintain secondary indexes for all rows in a table.

SAP Sybase IQ lets you split the data into several separate base tables (for example, by date). You load data into these smaller tables. You then join the tables back together into a logical whole by means of a UNION ALL view, which you can then query.

This strategy can improve load performance, but may negatively impact the performance of some types of queries. Most types of queries have roughly similar performance against a single base table or against a UNION ALL view over smaller base tables, as long as the view definition satisfies all constraints. However, some types of queries, especially those involving DISTINCT or involving joins with multiple join columns, may perform significantly slower against a UNION ALL view than against a single large base table. Before choosing to use this strategy, determine whether the improvements in load performance are worth the degradation in query performance for your application.

To create a UNION ALL view, choose a logical means of dividing a base table into separate physical tables. The most common division is by month. For example, to create a view including all months for the first quarter, enter:

```
CREATE VIEW
SELECT * JANUARY
UNION ALL
SELECT * FEBRUARY
UNION ALL
SELECT * MARCH
UNION ALL
```

Each month, you can load data into a single base table—JANUARY, FEBRUARY, or MARCH in this example. Next month, load data into a new table with the same columns, and the same index types.

---

**Note:** You cannot perform an INSERT . . . SELECT into a UNION ALL view. UNION ALL operators are not fully parallel in this release. Their use may limit query parallelism.

---

### See also

- *Indexing* on page 41
- *Join Column* on page 46
- *Primary Keys* on page 47
- *Foreign Keys* on page 47
- *Proper Data Type Sizing* on page 48
- *Null Values* on page 49
- *Unsigned Data Types* on page 49

- *LONG VARCHAR and LONG VARBINARY* on page 50
- *Large Object Storage* on page 51
- *Temporary Tables* on page 52
- *Denormalizing for Performance* on page 53
- *Hash Partitioning* on page 56

## **Queries Referencing UNION ALL Views**

To adjust performance for queries that reference `UNION ALL` views, set the `JOIN_PREFERENCE` option, which affects joins between `UNION ALL` views.

All partitions in a `UNION ALL` view must have a complete set of indexes defined for optimization to work. Queries with `DISTINCT` will tend to run more slowly using a `UNION ALL` view than a base table.

SAP Sybase IQ includes optimizations for `UNION ALL` views, including:

- Split `GROUP BY` over `UNION ALL` view
- Push-down join into `UNION ALL` view

A `UNION` can be treated as a partitioned table only if it satisfies all of the following constraints:

- It contains only one or more `UNION ALL`.
- Each arm of the `UNION` has only one table in its `FROM` clause, and that table is a physical base table.
- No arm of the `UNION` has a `DISTINCT`, a `RANK`, an aggregate function, or a `GROUP BY` clause.
- Each item in the `SELECT` clause within each arm of the `UNION` is a column.
- The sequence of data types for the columns in the `SELECT` list of the first `UNION` arm is identical to the sequence in each subsequent arm of the `UNION`.

### **See also**

- *UNION ALL View Performance* on page 55

## **UNION ALL View Performance**

Structure queries to evaluate the `DISTINCT` operator before the `ORDER BY`, where the sort order is `ASC`.

Certain optimizations, such as pushing a `DISTINCT` operator into a `UNION ALL` view, are not applied when the `ORDER BY` is `DESC` because the optimization that evaluates `DISTINCT` below a `UNION` does not apply to `DESC` order. For example, the following query would impact performance:

```
SELECT DISTINCT state FROM testVU ORDER BY state DESC;
```

To work around this performance issue, queries should have the `DISTINCT` operator evaluated before the `ORDER BY`, where the sort order is `ASC` and the optimization can be applied:

```
SELECT c.state FROM (SELECT DISTINCT state
                     FROM testVUA) c
ORDER BY c.state DESC;
```

### See also

- *Queries Referencing UNION ALL Views* on page 55

## Hash Partitioning

---

Hash table partitioning distributes data to logical partitions for parallel execution, which can enhance join performance on large tables and distributed queries (PlexQ).

New join algorithms and aggregation algorithms can take advantage of hash partitioning by reducing the amount of intermediate storage and network transfer required as well as providing increased parallelism by leveraging the semantic division of the table rows into partitions. The improved cache behavior provided by data affinity and affinity based work allocation provide further scalability in the PlexQ environment.

### *Using Hash Partitioned Join or Hash Partitioned Aggregation Algorithms*

To use the hash partitioned join or hash partitioned aggregation algorithms, it is critical that all the columns of the hash partitioning key for the table or tables, be used in the equi-join conditions or grouping expressions for those tables. Additional join conditions or grouping expressions may be used, but if a column that is a component of the hash partitioning key is not used in the query, the partitioned algorithms will not be eligible. In such a case, other non-partitioned algorithms remain eligible and would be chosen as for non-partitioned tables. Hash partitioning of a set of tables should cover the smallest common set of columns used by the application queries on those tables. Frequently a single column is a sufficient partitioning basis. It is essential that the data types of columns in joins between partitioned tables be identical.

Small tables benefit less from hash partitioning than large tables. Consider hash partitioning for tables of at least 1 billion rows.

### *Large Memory*

Some load operations may require more large memory than the 2GB default provides. If the memory requirements exceed the default, use the `-iqlm` startup option to increase the memory that SAP Sybase IQ can dynamically request from the OS.

As a general rule, large memory requirements represent one third of the total available physical memory allocated to SAP Sybase IQ. To ensure adequate memory for the main and temporary IQ stores, set the `-iqlm`, `-iqtc`, and `-iqmc` startup parameters so that each parameter receives one third of all available physical memory allocated to SAP Sybase IQ.

In most cases, you should allocate 80% of total physical memory to SAP Sybase IQ to prevent SAP Sybase IQ processes from being swapped out. Adjust actual memory allocation to accommodate other processes running on the same system. For example, on a machine with 32 cores and 128GB of total available physical memory, you would allocate 100GB (approximately 80% of the 128GB total) to SAP Sybase IQ processes. Following the general rule, you would set the `-iqlm`, `-iqtc`, and `-iqmc` parameters to 33GB each.

### *Additional Information*

- *Reference: Statements and Options > Database Options > Alphabetical List of Options > JOIN\_PREFERENCE Option*
- *Reference: Statements and Options > Database Options > Alphabetical List of Options > AGGREGATION\_PREFERENCE Option*
- *Utility Guide > start\_iq Database Server Startup Utility > start\_iq Server Options > -iqlm iqsrv16 Server Option*
- *Utility Guide > start\_iq Database Server Startup Utility > start\_iq Server Options > -iqmc iqsrv16 Server Option*
- *Utility Guide > start\_iq Database Server Startup Utility > start\_iq Server Options > -iqtc iqsrv16 Server Option*

### **See also**

- *Indexing* on page 41
- *Join Column* on page 46
- *Primary Keys* on page 47
- *Foreign Keys* on page 47
- *Proper Data Type Sizing* on page 48
- *Null Values* on page 49
- *Unsigned Data Types* on page 49
- *LONG VARCHAR and LONG VARBINARY* on page 50
- *Large Object Storage* on page 51
- *Temporary Tables* on page 52
- *Denormalizing for Performance* on page 53
- *UNION ALL Views for Faster Loads* on page 54





# Troubleshooting

Identify and solve common performance issues.

## Isolating Performance Problems

---

Determine whether the problem is external or internal to SAP Sybase IQ.

### *External to SAP Sybase IQ*

- Monitor the OS, hardware, and storage for any bottlenecks or issues
- Look for high CPU use, high CPU system time, low CPU user time, high wait time
- Look for I/O service times that are more than 10ms

### *Internal to SAP Sybase IQ*

- Enable `INDEX_ADVISOR` and look for missing indexes
- Enable `QUERY_PLAN_AS_HTML` and the `INDEX_ADVISOR` if the issue is with a single query

### See also

- *Diagnostic Tools* on page 59
- *Common Performance Issues* on page 60

## Diagnostic Tools

---

Utilities on your operating system that monitor system activities.

Use these utilities to get statistics on the number of running processes, including and the number of page-outs and swaps. Use this information to find out if the system is paging excessively, then make any necessary adjustments. You may want to put your swap files on special fast disks.

OS	Utility	Description
UNIX	<b>top</b> , <b>topas</b>	Provides an ongoing look at processor activity in real time.  <b>top</b> is available on Solaris, Linux, and HP-UX platforms. <b>topas</b> is available on AIX.

OS	Utility	Description
	<b>ps</b>	Reports process status.
	<b>vmstat</b>	Displays information about system processes, memory, paging, block IQ, traps, and CPU activity.
	<b>iostat -x</b>	Displays disk subsystem information.
	<b>sar</b>	Writes selected OS activity results to standard output.
Windows	<b>Task Manager, Resource Monitor</b>	Provide detailed information about computer performance and running applications, processes, CPU usage, and other system services.

---

**Note:** To access System Monitor, select the object Logical Disk, the instance of the disk containing the file PAGEFILE.SYS, and the counter Disk Transfers/Sec.

Put the Windows page files on different disks than your database dbspace devices. You can also monitor the Object Memory and the counter Pages/Sec. However, this value is the sum of all memory faults which includes both soft and hard faults.

---

**See also**

- *Isolating Performance Problems* on page 59
- *Common Performance Issues* on page 60

## Common Performance Issues

---

Solutions to common performance problems.

**See also**

- *Isolating Performance Problems* on page 59
- *Diagnostic Tools* on page 59

## Paging and Disk Swapping

Good memory management avoids page swapping. To minimize use of operating system files, increase or reallocate physical memory.

Insufficient memory severely degrades performance. If this is the case, you need to find a way to make more memory available. The more memory you can allocate to SAP Sybase IQ, the better.

Because there is always a fixed limit to the amount of memory, the operating system may sometimes keep part of the data in memory and the rest on disk. Paging or swapping occurs

when the operating system must go out to disk and retrieve any data before a memory request can be satisfied. Good memory management avoids or minimizes paging or swapping.

The most frequently used operating system files are swap files. When memory is exhausted, the operating system swaps pages of memory to disk to make room for new data. When the pages that were swapped are called again, other pages are swapped, and the required memory pages are brought back. This is very time-consuming for users with high disk usage rates. Try to organize memory to avoid swapping and, thus, to minimize use of operating system files.

To make the maximum use of your physical memory, SAP Sybase IQ uses buffer caches for all reads and writes to your databases.

---

**Note:** Your swap space on disk must be at least large enough to accommodate all of your physical memory. Having swap/paging space striped across fast disks is essential.

---

### See also

- *Index and Row Fragmentation* on page 61
- *Catalog File Growth* on page 62
- *Thrashing and Query Execution* on page 62

## Index and Row Fragmentation

Internal index fragmentation occurs when index pages are not being used to their maximum volume. Row fragmentation occurs when rows are deleted. Deleting an entire page of rows frees the page, but if some rows on a page are unused, the unused space remains on the disk. DML operations (INSERT, UPDATE, DELETE) on tables can cause index fragmentation.

Run these stored procedures for information about fragmentation issues:

- **sp\_iqrowdensity** reports row fragmentation at the FP index level.
- **sp\_iqindexfragmentation** reports internal fragmentation within supplemental indexes. .

Review the output and decide whether you want to recreate, reorganize, or rebuild the indexes. You can create other indexes to supplement the FP index.

### *Additional Information*

- *Reference: Building Blocks, Tables, and Procedures > System Procedures > sp\_iqrowdensity procedure.*
- *Reference: Building Blocks, Tables, and Procedures > System Procedures > sp\_iqindexfragmentation procedure.*

### See also

- *Paging and Disk Swapping* on page 60
- *Catalog File Growth* on page 62
- *Thrashing and Query Execution* on page 62

## **Catalog File Growth**

Growth of the catalog files is normal and varies depending on the application and catalog content. The size of the .db file does not affect performance, and free pages within the .db file are reused as needed.

To minimize catalog file growth:

- Avoid using `IN SYSTEM` on `CREATE TABLE` statements
- Issue `COMMIT` statements after running system stored procedures
- Issue `COMMIT` statements during long-running transactions

### **See also**

- *Paging and Disk Swapping* on page 60
- *Index and Row Fragmentation* on page 61
- *Thrashing and Query Execution* on page 62

## **Thrashing and Query Execution**

Adjust the `HASH_THRASHING_PERCENT` option to limit thrashing during queries that involve hash algorithms.

Adjusting the `HASH_THRASHING_PERCENT` database option controls the percentage of hard disk I/Os allowed before the statement is rolled back and an error is returned. The default value of `HASH_THRASHING_PERCENT` is 10%. Increasing `HASH_THRASHING_PERCENT` permits more paging to disk before a rollback and decreasing `HASH_THRASHING_PERCENT` permits less paging before a rollback.

Queries involving hash algorithms that executed in earlier versions of SAP Sybase IQ may now be rolled back when the default `HASH_THRASHING_PERCENT` limit is reached. SAP Sybase IQ reports the error

```
Hash insert thrashing detected
```

or

```
Hash find thrashing detected
```

Take one or more of the following actions to provide the query with the resources required for execution:

- Relax the paging restriction by increasing the value of `HASH_THRASHING_PERCENT`.
- Increase the size of the temporary cache. Keep in mind that increasing the size of the temporary cache requires an equal size reduction in main cache allocation to prevent the possibility of system thrashing.

- Attempt to identify and alleviate why SAP Sybase IQ is not estimating one or more hash sizes for this statement correctly. For example, check that all columns that need an LF or HG index have one. Also consider if a multicolumn index is appropriate.
- Decrease the value of the database option `HASH_PINNABLE_CACHE_PERCENT`.

To identify possible problems with a query, generate a query plan by running the query with the temporary database options `QUERY_PLAN='ON'` and `QUERY_DETAIL='ON'`. Examine the estimates in the query plan.

**See also**

- *Paging and Disk Swapping* on page 60
- *Index and Row Fragmentation* on page 61
- *Catalog File Growth* on page 62



# Queries and Deletions

Recommendations to help you plan, structure, and control your queries.

## Structuring Queries

---

Improving query structures can make your queries run faster.

- In some cases, command statements that include subqueries can also be formulated as joins and may run faster.
- If you group on multiple columns in a `GROUP BY` clause, list the columns by descending order by number of unique values if you can. This will give you the best query performance.
- You can improve performance by using an additional column to store frequently calculated results.

## Enhancing ORDER BY Query Performance

Using multicolumn `HG` indexes can enhance the performance of `ORDER BY` queries.

You can use multicolumn `HG` indexes to enhance the performance of `ORDER BY` queries with reference to multiple columns in a single table query. This change is transparent to users, but improves query performance.

Queries with multiple columns in the `ORDER BY` clause may run faster using multicolumn `HG` indexes. For example, if the user has multicolumn index `HG (x, y, z)` on table `T`, then this index is used for ordered projection:

```
SELECT abs (x) FROM T
ORDER BY x, y
```

In the above example, the `HG` index vertically projects `x` and `y` in sorted order.

If the `ROWID ()` function is in the `SELECT` list expressions, multicolumn `HG` indexes are also used. For example:

```
SELECT rowid()+x, z FROM T
ORDER BY x, y, z
```

If `ROWID ()` is present at the end of an `ORDER BY` list, and if the columns of that list—except for `ROWID ()`—exist within the index, and the ordering keys match the leading `HG` columns in order, multicolumn indexes are used for the query. For example:

```
SELECT z, y FROM T
ORDER BY x, y, z, ROWID ()
```

### See also

- *Improved Subquery Performance* on page 66
- *Using Caching Methods* on page 66

## Improved Subquery Performance

Use `SUBQUERY_FLATTENING_PREFERENCE` and `SUBQUERY_FLATTENING_PERCENT` to control subquery flattening.

Subquery flattening is an optimization technique in which the optimizer rewrites a query containing a subquery into a query that uses a join. SAP Sybase IQ flattens many but not all subqueries. Use `SUBQUERY_FLATTENING_PREFERENCE` and `SUBQUERY_FLATTENING_PERCENT` to control when the optimizer chooses to use this optimization.

### See also

- *Enhancing ORDER BY Query Performance* on page 65
- *Using Caching Methods* on page 66

## Using Caching Methods

Set the `SUBQUERY_CACHING_PREFERENCE` option to choose caching methods for a correlated subquery.

A correlated subquery contains references to one or more tables outside of the subquery and is re-executed each time the value in the referenced column changes. Use the `SUBQUERY_CACHING_PREFERENCE` option to choose caching methods for executing the correlated subquery.

### See also

- *Enhancing ORDER BY Query Performance* on page 65
- *Improved Subquery Performance* on page 66

## Generating Query Plans

Generating a query plan can help you understand the execution plan developed by the optimizer.

Before it executes any query, the query optimizer creates a query execution plan. A query execution plan represents the set of steps the database server uses to access information in the database related to a statement. The execution plan for a statement can be saved and reviewed, regardless of whether it was just optimized, whether it bypassed the optimizer, or whether its plan was cached from previous executions. Although a query execution plan may not correspond exactly to the syntax used in the original statement, operations described in the execution plan are semantically equivalent to the original query.



Query plans generate an execution tree that consists of a series of nodes that represent a processing stage. The lowest nodes on the tree are leaf nodes. Each leaf node represents a table in the query. At the top of the plan is the root of the operator tree. Information flows up from the tables and through any operators representing joins, sorts, filters, stores, aggregation, and subqueries.

### *Load Execution Plans*

Load execution plans detail the steps that the database engine uses to insert data into a table. Load plans use the same database and output options as query execution plans. The Data Flow Object (DFO) tree identifies the number of rows processed at each stage of the load. Different SQL statements may generate different DFO trees and the same statement may generate different trees for different kind of tables (un-partitioned, range partitioned, hash partitioned, hash-range partitioned, etc.).

### *Generating Query Plans*

To generate a query plan, set the appropriate evaluation options, then execute the query. Text versions of the plan are written to the `.iqmsg` file. HTML versions can be displayed in the **Interactive SQL Plan Viewer** or in most Web browsers.

---

**Note:** Use query plans only to evaluate the efficiency of a particular query or load. Running SAP Sybase IQ with the `QUERY_PLAN` option set to `ON` can significantly impact performance, particularly as the volume of **INSERT...VALUE** statements increase.

---

## Query Evaluation Options

Setting the appropriate options helps you evaluate the query plan.

- `INDEX_ADVISOR` – When set `ON`, the index advisor prints index recommendations as part of the Sybase IQ query plan or as a separate message in the Sybase IQ message log file if query plans are not enabled. These messages begin with the string “Index Advisor:” and you can use that string to search and filter them from a Sybase IQ message file. This option outputs messages in `OWNER . TABLE . COLUMN` format and is `OFF` by default.

See also the “`sp_iqindexadvice` procedure” in “System Procedures” in the *Reference: Building Blocks, Tables, and Procedures*.

- `INDEX_ADVISOR_MAX_ROWS` – Used to limit the number of messages stored by the index advisor. Once the specified limit has been reached, the `INDEX_ADVISOR` will not store new advice. It will, however, continue to update count and timestamps for existing advice.
- `NOEXEC` – When set `ON`, Sybase IQ produces a query plan but does not execute the entire query. When the `EARLY_PREDICATE_EXECUTION` option is `ON`, some portions of a query are still executed.

If `EARLY_PREDICATE_EXECUTION` is `OFF`, the query plan may be very different than when the query is run normally, so turning it `OFF` is not recommended.

- `QUERY_DETAIL` – When this option and either `QUERY_PLAN` or `QUERY_PLAN_AS_HTML` are both `ON`, Sybase IQ displays additional information about

the query when producing its query plan. When `QUERY_PLAN` and `QUERY_PLAN_AS_HTML` are `OFF`, this option is ignored.

- `QUERY_PLAN` – When set `ON` (the default), Sybase IQ produces messages about queries.
- `QUERY_PLAN_TEXT_ACCESS` – When this option is turned `ON`, you can view, save, and print IQ query plans from the Interactive SQL client. When `QUERY_PLAN_ACCESS_FROM_CLIENT` is turned `OFF`, query plans are not cached, and other query plan-related database options have no effect on the query plan display from the Interactive SQL client. This option is `OFF` by default.

See “`GRAPHICAL_PLAN` function [String]” and “`HTML_PLAN` function [String]” in *Reference: Building Blocks, Tables, and Procedures*.

- `QUERY_PLAN_AFTER_RUN` – When set `ON`, the query plan is printed after the query has finished running. This allows the plan to include additional information, such as the actual number of rows passed on from each node of the query. In order for this option to work, `QUERY_PLAN` must be `ON`. This option is `OFF` by default.
- `QUERY_PLAN_AS_HTML` – Produces a graphical query plan in HTML format for viewing in a Web browser. Hyperlinks between nodes make the HTML format much easier to use than the text format in the `.iqmsg` file. Use the `QUERY_NAME` option to include the query name in the file name for the query plan. This option is `OFF` by default.
- `QUERY_PLAN_AS_HTML_DIRECTORY` – When `QUERY_PLAN_AS_HTML` is `ON` and a directory is specified with `QUERY_PLAN_AS_HTML_DIRECTORY`, Sybase IQ writes the HTML query plans in the specified directory.
- `QUERY_PLAN_TEXT_CACHING` – Gives users a mechanism to control resources for caching plans. With this option `OFF` (the default), the query plan is not cached for that user connection.

If the `QUERY_PLAN_TEXT_ACCESS` option is turned `OFF` for a user, the query plan is not cached for the connections from that user, no matter how `QUERY_PLAN_TEXT_CACHING` is set.

See also “`GRAPHICAL_PLAN` function [String]” and “`HTML_PLAN` function [String]” in *Reference: Building Blocks, Tables, and Procedures*.

- `QUERY_TIMING` – Controls the collection of timing statistics on subqueries and some other repetitive functions in the query engine. Normally it should be `OFF` (the default) because for very short correlated subqueries the cost of timing every subquery execution can be very expensive in terms of performance.
- `QUERY_PLAN_MIN_TIME` – Specifies a threshold for query execution. The query plan is generated only if query execution time exceeds the threshold in microseconds. This can improve system performance by turning off query plan generation for queries with very short execution times.

---

**Note:** Query plans can add a lot of text to your `.iqmsg` file. When `QUERY_PLAN` is `ON`, and especially if `QUERY_DETAIL` is `ON`, you might want to enable message log wrapping or message log archiving to avoid filling up your message log file.

---

**See also**

- *Using Query Plans* on page 69

**Using Query Plans**

Set the `QUERY_PLAN_AS_HTML` option to generate an HTML version of the query plan that you can view in a Web browser.

HTML versions can be displayed in the Interactive **SQL Plan Viewer**. HTML query plan, each node in the tree is hyper-linked to processing details. You can click on any node to navigate quickly through the plan.

SQL functions `GRAPHICAL_PLAN` and `HTML_PLAN` return IQ query plans in XML and HTML format, respectively, as a string result set. Database options `QUERY_PLAN_TEXT_ACCESS` and `QUERY_PLAN_TEXT_CACHING` control the behavior of the new functions.

View graphical query plans in the Interactive **SQL Plan Viewer**. Text plans are not supported in the **Plan Viewer** return the error message, `Plan type is not supported`. Use the SQL functions, `GRAPHICAL_PLAN` and `HTML_PLAN`, to return the query plan as a string result.

*Additional Information*

- *Reference: Building Blocks, Tables, and Procedures > SQL Functions > GRAPHICAL\_PLAN function [String]*
- *Reference: Building Blocks, Tables, and Procedures > SQL Functions > HTML\_PLAN function [String]*
- *Reference: Statements and Options > Database Options > QUERY\_PLAN\_TEXT\_ACCESS Option*
- *Reference: Statements and Options > Database Options > QUERY\_PLAN\_TEXT\_CACHING Option*

**See also**

- *Query Evaluation Options* on page 67

**Controlling Query Processing**

Any user can set limits on the amount of time spent processing a particular query. Users with the `SET ANY PUBLIC OPTION` system privilege can give certain users' queries priority over others, or change processing algorithms to influence the speed of query processing.

### **Setting Query Time Limits**

Set the `MAX_QUERY_TIME` option to limit the time a query can run. If a query takes longer to execute than the `MAX_QUERY_TIME`, SAP Sybase IQ stops the query with an appropriate error.

---

**Note:** SAP Sybase IQ truncates all decimal *option-value* settings to integer values. For example, the value 3.8 is truncated to 3.

---

#### **See also**

- *Setting Query Priority* on page 70
- *Setting Query Optimization Options* on page 71
- *Setting User-Supplied Condition Hints* on page 71
- *Monitoring Workloads* on page 72

### **Setting Query Priority**

Setting query priority options assigns query processing priorities by user.

Queries waiting in queue for processing are queued to run in order of the priority of the user who submitted the query, followed by the order in which the query was submitted. No queries are run from a lower priority queue until higher priority queries have all been executed.

The following options assign queries a processing priority by user.

- `IQGOVERN_PRIORITY` – Assigns a numeric priority (1, 2, or 3, with 1 being the highest) to queries waiting in the processing queue.
- `IQGOVERN_MAX_PRIORITY` – Allows users with the `SET ANY SYSTEM OPTION` system privilege to set an upper boundary on `IQGOVERN_PRIORITY` for a user or a role.
- `IQ_GOVERN_PRIORITY_TIME` – Allows high priority users to start if a high priority (priority 1) query has been waiting in the `-iqgovern` queue for more than a designated amount of time.

To check the priority of a query, check the `IQGovernPriority` attribute returned by the `sp_iqcontext` stored procedure.

#### **See also**

- *Setting Query Time Limits* on page 70
- *Setting Query Optimization Options* on page 71
- *Setting User-Supplied Condition Hints* on page 71
- *Monitoring Workloads* on page 72

## Setting Query Optimization Options

Optimization options affect query processing speed.

- `AGGREGATION_PREFERENCE` – Controls the choice of algorithms for processing an aggregate (`GROUP BY`, `DISTINCT`, `SET` functions). This option is designed primarily for internal use; do not use it unless you are an experienced database administrator.
- `DEFAULT_HAVING_SELECTIVITY_PPM` – Sets the selectivity for all `HAVING` predicates in a query, overriding optimizer estimates for the number of rows that will be filtered by the `HAVING` clause.
- `DEFAULT_LIKE_MATCH_SELECTIVITY_PPM` – Sets the default selectivity for generic `LIKE` predicates, for example, `LIKE 'string%string'` where `%` is a wildcard character. The optimizer relies on this option when other selectivity information is not available and the match string does not start with a set of constant characters followed by a single wildcard.
- `DEFAULT_LIKE_RANGE_SELECTIVITY_PPM` – Sets the default selectivity for leading constant `LIKE` predicates, of the form `LIKE 'string%'` where the match string is a set of constant characters followed by a single wildcard character (`%`). The optimizer relies on this option when other selectivity information is not available.
- `MAX_HASH_ROWS` – Sets the maximum estimated number of rows the query optimizer will consider for a hash algorithm. The default is 2,500,000 rows. For example, if there is a join between two tables, and the estimated number of rows entering the join from both tables exceeds this option value, the optimizer will not consider a hash join. On systems with more than 50MB per user of `TEMP_CACHE_MEMORY_MB`, you may want to consider a higher value for this option.
- `MAX_JOIN_ENUMERATION` – Sets the maximum number of tables to be optimized for join order after optimizer simplifications have been applied. Normally you should not need to set this option.

### **See also**

- *Setting Query Time Limits* on page 70
- *Setting Query Priority* on page 70
- *Setting User-Supplied Condition Hints* on page 71
- *Monitoring Workloads* on page 72

## Setting User-Supplied Condition Hints

Selectivity hints help the optimizer choose an appropriate query strategy.

The SAP Sybase IQ query optimizer uses information from available indexes to select an appropriate strategy for executing a query. For each condition in the query, the optimizer decides whether the condition can be executed using indexes, and if so, the optimizer chooses which index and in what order with respect to the other conditions on that table. The most

important factor in these decisions is the selectivity of the condition; that is, the fraction of the table's rows that satisfy that condition.

The optimizer normally decides without user intervention, and it generally makes optimal decisions. In some situations, however, the optimizer might not be able to accurately determine the selectivity of a condition before it has been executed. These situations normally occur only where either the condition is on a column with no appropriate index available, or where the condition involves some arithmetic or function expression and is, therefore, too complex for the optimizer to accurately estimate.

### *Additional Information*

- *Reference: Building Blocks, Tables, and Procedures > SQL Language Elements > User-supplied Condition Hints*

### **See also**

- *Setting Query Time Limits* on page 70
- *Setting Query Priority* on page 70
- *Setting Query Optimization Options* on page 71
- *Monitoring Workloads* on page 72

## **Monitoring Workloads**

Use the stored procedures that monitor table, column, and index usage for better query performance.

Indexes are often created to provide optimization metadata and to enforce uniqueness and primary/foreign key relationships. Once an index is created, however, DBAs face the challenge of quantifying benefits that the index provides.

Tables are often created in the IQ Main Store for the temporary storage of data that must be accessed by multiple connections or over a long period. These tables might be forgotten while they continue to use valuable disk space. Moreover, the number of tables in a data warehouse is too large and the workloads are too complex to manually analyze usage.

Thus, unused indexes and tables waste disk space, increase backup time, and degrade DML performance.

SAP Sybase IQ offers tools for collecting and analyzing statistics for a defined workload. DBAs can quickly determine which database objects are being referenced by queries and should be kept. Unused tables/columns/indexes can be dropped to reduce wasted space, improve DML performance, and decrease backup time.

Workload monitoring is implemented using stored procedures, which control the collection and report detailed usage of table, column, and index information. These procedures complement INDEX\_ADVISOR functionality, which generates messages suggesting additional column indexes that may improve performance of one or more queries. Once

recommended indexes have been added, their usage can be tracked to determine if they are worth keeping.

### See also

- *Setting Query Time Limits* on page 70
- *Setting Query Priority* on page 70
- *Setting Query Optimization Options* on page 71
- *Setting User-Supplied Condition Hints* on page 71

## Optimizing Delete Operations

---

SAP Sybase IQ chooses the best algorithm to process delete operations on columns with HG and WD indexes.

### HG Delete Operations

SAP Sybase IQ chooses one of three algorithms to process delete operations on columns with an HG (High\_Group) index.

- Small delete provides optimal performance when rows are deleted from very few groups. It is typically selected when the delete is only 1 row or the delete has an equality predicate on the columns with an HG index. The small delete algorithm can randomly access the HG. Worst case I/O is proportional to the number of groups visited.
- Mid delete provides optimal performance when rows are deleted from several groups, but the groups are sparse enough or few enough that not many HG pages are visited. The mid delete algorithm provides ordered access to the HG. Worst case I/O is bounded by the number of index pages. Mid delete has the added cost of sorting the records to delete.
- Large delete provides optimal performance when rows are deleted from a large number of groups. The large delete scans the HG in order until all rows are deleted. Worst case I/O is bounded by the number of index pages. Large delete is parallel, but parallelism is limited by internal structure of the index and the distribution of group to deleted from. Range predicates on HG columns can be used to reduce the scan range of the large delete.

#### *HG Delete Costing*

The delete cost model considers many factors including I/O costs, CPU costs, available resources, index metadata, parallelism, and predicates available from the query.

Specifying predicates on columns that have HG, LF, or `enumerated` FP indexes greatly improves costing. In order for the HG costing to pick an algorithm other than large delete, it must be able to determine the number of distinct values (groups) affected by deletions. Distinct count is initially assumed to be lesser of the number of index groups and the number of rows deleted. Predicates can provide an improved or even exact estimate of the distinct count.

Costing currently does not consider the effect of range predicates on the large delete. This can cause mid delete to be chosen in cases where large delete would be faster. You can force the large delete algorithm if needed in these cases, as described in the next section.

### *Using HG Delete Performance Option*

You can use the `HG_DELETE_METHOD` option to control HG delete performance.

The value of the parameter specified with the `HG_DELETE_METHOD` option forces the use of the specified delete algorithm as follows:

- 1 = Small delete
- 2 = Large delete
- 3 = Mid delete
- `DML_OPTIONS5 = 4` (Disable Push Delete Predicates) Default 0 — Disables pushing range predicates to the HG large delete.

For more information on the `HG_DELETE_METHOD` database option, see “`HG_DELETE_METHOD` option” in “Database Options” in *Reference: Statements and Options*.

### **See also**

- *WD Delete Operations* on page 74
- *TEXT Delete Operations* on page 75

## **WD Delete Operations**

SAP Sybase IQ chooses one of three algorithms to process delete operations on columns with a **WD** (Word) index.

- Small delete provides optimal performance when the rows deleted contain few distinct words, so that not many **WD** pages need to be visited. The **WD** small delete algorithm performs an ordered access to the **WD**. Worst case I/O is bounded by the number of index pages. Small delete incorporates the cost of sorting the words and record IDs in the records to delete.
- Mid delete for **WD** is a variation of **WD** small delete, and is useful under the same conditions as small delete, that is, when the rows deleted contain few distinct words. Mid delete for **WD** sorts only words in the records to delete. This sort is parallel, with parallelism limited by the number of words and CPU threads available. For Word index, the mid delete method is generally faster than small delete.
- Large delete provides optimal performance when the rows deleted contain a large number of distinct words, and therefore need to visit a large number of “groups” in the index. The large delete scans the **WD** in order, until all rows are deleted. Worst case I/O is bounded by the number of index pages. Large delete is parallel, but parallelism is limited by the internal structure of the index and the distribution of groups from which to delete.



### *WD Delete Costing*

The WD delete cost model considers many factors including I/O costs, CPU costs, available resources, index metadata, and parallelism.

You can use the `WD_DELETE_METHOD` database option to control WD delete performance.

### *Using WD Delete Performance Option*

The value of the parameter specified with the `WD_DELETE_METHOD` option forces the use of the specified delete algorithm as follows:

- 0 = Mid or large delete as selected by the cost model
- 1 = Small delete
- 2 = Large delete
- 3 = Mid delete

For more information on the `WD_DELETE_METHOD` database option, see “`WD_DELETE_METHOD` option” in “Database Options” of *Reference: Statements and Options*.

### **See also**

- *HG Delete Operations* on page 73
- *TEXT Delete Operations* on page 75

## **TEXT Delete Operations**

SAP Sybase IQ chooses one of two algorithms to process delete operations on columns with a `TEXT` index.

- Small delete provides optimal performance when the rows deleted contain few distinct words, so that not many `TEXT` pages need to be visited. The `TEXT` small delete algorithm performs an ordered access to the `TEXT`. Worst case I/O is bounded by the number of index pages. Small delete incorporates the cost of sorting the words and record IDs in the records to delete.
- Large delete provides optimal performance when the rows deleted contain a large number of distinct words, and therefore need to visit a large number of “groups” in the index. The large delete scans the `TEXT` in order, until all rows are deleted. Worst case I/O is bounded by the number of index pages. Large delete is parallel, but parallelism is limited by the internal structure of the index and the distribution of groups from which to delete.

### *TEXT Delete Costing*

The `TEXT` delete cost model considers many factors including I/O costs, CPU costs, available resources, index metadata, and parallelism.

You can use the `TEXT_DELETE_METHOD` database option to control `TEXT` delete performance.

### *Using TEXT Delete Performance Option*

The value of the parameter specified with the `TEXT_DELETE_METHOD` option forces the use of the specified delete algorithm as follows:

- 0 = Mid or large delete as selected by the cost model
- 1 = Small delete
- 2 = Large delete

For more information on the `TEXT_DELETE_METHOD` database option, see “`TEXT_DELETE_METHOD` option” in “TEXT Indexes and Text Configuration Objects” of *Unstructured Data Analytics in Sybase IQ*.

### **See also**

- *HG Delete Operations* on page 73
- *WD Delete Operations* on page 74

# Index

-gm 15  
 -iqgovern  
     Restricting Queries To Improve Performance  
     16  
 -iqwmem 13

## A

AGGREGATION\_ALGORITHM\_  
 PREFERENCE 71

## B

Block Size  
     Relationship To IQ Page Size 12  
 BT\_PREFETCH\_MAX\_MISS 20  
 Buffer Cache  
     Block Size 12  
     Data Compression 12  
     Database Access, Multiuser 9  
     Memory Use 9  
     Memory, Saving 12  
     Overhead 9  
     Page Size 12  
     Thread Stacks 9  
 Buffer Cache Performance 32  
     Cache Monitor 32  
     Cache Monitor Checklist 32  
 Buffer Caches  
     Layout 23

## C

Cache Memory  
     -iqmc 11  
     -iqtc 11  
     Cache Size 11  
     Parameters 11  
     Prefetching Pages 20  
 Cache Monitor Checklist 32  
 CACHE\_PARTITIONS 23  
 Caching Methods 66  
 Catalog File Growth 62  
 CMP indexes 42, 43

Columns  
     Null Values 65  
 Common performance issues 60  
 Condition Hints  
     Setting 71  
 Connections  
     Connection Requests 15  
     Limiting Statements 20  
 CPU  
     availability 5  
     setting number 5  
 Cursors  
     Forcing Non-scrolling 18  
     Limiting 19

## D

Data Compression  
     Page Size 12  
 Data Model Recommendations 41  
 Data Type Sizing 48  
 Data types  
     LONG VARBINARY 50  
     LONG VARCHAR 50  
     Null Values 49  
     Sizing 48  
 Data Types  
     Unsigned Data Types 49  
 Database Access  
     Multiuser 9  
 Databases  
     Procedure Profiling 28  
     Procedures 28  
 DATABASES  
     DENORMALIZING FOR PERFORMANCE  
     53  
 DATE indexes 42, 43  
 DbSPACE  
     Limiting Use 17  
 DEFAULT\_HAVING\_SELECTIVITY 71  
 DEFAULT\_LIKE\_MATCH\_SELECTIVITY 71  
 DEFAULT\_LIKE\_RANGE\_SELECTIVITY 71  
 Delete Operations  
     Optimizing 73  
     TEXT Delete Operations 75  
     WD Delete Operations 74

## Index

### DELETE OPERATIONS

HG Delete Operations 73

Diagnostic Tools 59

disk space

    multiplex databases 39

Disk Space

    Conserving 27

    Limiting message log size 27

    Swap Space 60

    Truncating transaction log 27

Disk Striping 24

    Internal Striping 25

distributed query processing 39

DTTM indexes 42, 43

## E

EARLY\_PREDICATE\_EXECUTION 71

Evaluating

    Loads 66

    Queries 66

Event Profiling Procedures 30

## F

File Access

    Random Files 26

    Sequential Files 26

File System Buffering 22

FLATTEN\_SUBQUERIES 66

FORCE\_NO\_SCROLL\_CURSORS 18

Foreign Keys 47

FROM Clause 55

## G

GRAPHICAL\_PLAN 69

## H

Hash Partitioning 56

HG Delete Operations 73

HG indexes 42, 43

HG Indexes 65

    Loads 44

    Operations 44

    Schema Design 44

HNG indexes 42, 43

HTML\_PLAN 69

hyperthreading

    server switch 5

## I

I/O

    performance recommendations 24

IN\_SUBQUERY\_PREFERENCE 71

Index and Row Fragmentation 61

Index Selection 42, 43

    CMP 43

    DATE 43

    DTTM 43

    HG 43

    HNG 43

    LF 43

    TIME 43

    WD 43

INDEX\_ADVISOR 67

INDEX\_PREFERENCE 71

Indexes

    Choosing 41

    CMP 43

    DATE 43

    DTTM 43

    HG 41, 43, 65

    HG Index Loads 44

    HG Indexes 44

    HNG 43

    Index Advisor 41

    Index Selection 43

    Indexes 44

    LF 41, 43

    Multi-Column Indexes 45

    Multicolumn 65

    TIME 43

    Types 41

    WD 43

Input/Output

    Disk Striping 24

    Internal Striping 25

    Message Log 27

    Random File Access 26

    Raw devices 24

    Sequential File Access 26

    Transaction log 27

Internal Striping 25

IOS\_FILE\_CACHE\_BUFFERING 22

IQ\_USE\_DIRECTIO 22

IQGOVERN\_MAX\_PRIORITY 70

IQGOVERN\_PRIORITY 70  
 iqnumbercpus  
   setting number of CPUs 5

## J

Join Column 46  
 JOIN\_ALGORITHM\_PREFERENCE 71  
 JOIN\_PREFERENCE 55

## K

Key Performance Indicators  
   Logical Server Statistics 30  
   Multiplex and Node-Related Statistics 30  
   Server Statistics 30

### Keys

  Foreign Keys 47  
   Primary Keys 47

## L

Large Memory  
   -iqmc 11  
   -iqtc 11  
   Multiplex Servers 11  
   Simplex Servers 11  
 Large Object Storage 51  
 LF indexes 42, 43  
 lightweight processes 5  
 load balancing  
   among query servers 40  
 Load Plans 66  
 Logical Server Statistics 30  
 logical servers 39  
 LONG VARBINARY 50  
 LONG VARCHAR 50

## M

management, resources  
   buffer cache 3  
 MAX\_CURSOR\_COUNT 19  
 MAX\_HASH\_ROWS 71  
 MAX\_QUERY\_TIME 70  
 MAX\_STATEMENT\_COUNT 20  
 memory  
   balancing I/O 24  
   lightweight processes 5

  multithreading 5  
   process threading model 5  
 Memory 9  
   Cache Memory 11  
   Cache Size 11  
   Connection Requests 15  
   File System Buffering 22  
   Heap Memory 9  
   IOS\_FILE\_CACHE\_BUFFERING 22  
   IQ\_USE\_DIRECTIO 22  
   Large Memory 11  
   Limits 9  
   Page Size 12  
   Required Memory 9  
   Server Memory 9  
   Wired Memory 13  
 Memory Use  
   Other 9  
 Message Log  
   Limiting Size 27  
 Monitoring Performance  
   Buffer Cache Performance 32  
   Cache Monitor 32  
   Database Profiling Procedures 28  
   Event Profiling Procedures 30  
   Key Performance Indicators 30  
 Monitoring Workloads 72  
 Multi-Column Indexes 45  
 Multi-user Performance 20  
 Multicolumn Indexes 65  
 multiplex 39  
 Multiplex and Node-Related Statistics 30  
 multiplex databases  
   disk space 39  
 multiplex resources  
   dynamically adjusting 39  
 multithreading  
   performance impact 5

## N

networks  
   large data transfers 6  
   networks 6  
   performance 6  
   performance suggestions 6  
   settings 6  
 Null Values 49

## Index

### O

#### Optimizing

Queries 65

#### Optimizing Queries 41, 65

#### Options

AGGREGATION\_ALGORITHM\_PREFERENCE 71  
BT\_PREFETCH\_MAX\_MISS 20  
CACHE\_PARTITIONS 23  
DEFAULT\_HAVING\_SELECTIVITY 71  
DEFAULT\_LIKE\_MATCH\_SELECTIVITY 71  
DEFAULT\_LIKE\_RANGE\_SELECTIVITY 71  
EARLY\_PREDICATE\_EXECUTION 71  
FLATTEN\_SUBQUERIES 66  
IN\_SUBQUERY\_PREFERENCE 71  
INDEX\_PREFERENCE 71  
IQ\_USE\_DIRECTIO 22  
JOIN\_ALGORITHM\_PREFERENCE 71  
JOIN\_PREFERENCE 55  
MAX\_CURSOR\_COUNT 19  
MAX\_HASH\_ROWS 71  
MAX\_STATEMENT\_COUNT 20  
OS\_FILE\_CACHE\_BUFFERING 22  
OS\_FILE\_CACHE\_BUFFERING\_TEMPDB 22  
PREFETCH\_BUFFER\_LIMIT 20  
QUERY\_ROWS\_RETURNED\_LIMIT 18  
QUERY\_TEMP\_SPACE\_LIMIT 17  
SUBQUERY\_CACHING\_PREFERENCE 66  
SUBQUERY\_FLATTENING\_PERCENT 66  
SUBQUERY\_FLATTENING\_PREFERENCE 66  
SWEEPER\_THREADS\_PERCENT 23  
USER\_RESOURCE\_RESERVATION 14  
WASH\_AREA\_BUFFERS\_PERCENT 23

#### Options, Query Optimization

AGGREGATION\_ALGORITHM\_PREFERENCE 71  
DEFAULT\_HAVING\_SELECTIVITY 71  
DEFAULT\_LIKE\_MATCH\_SELECTIVITY 71  
DEFAULT\_LIKE\_RANGE\_SELECTIVITY 71  
EARLY\_PREDICATE\_EXECUTION 71  
IN\_SUBQUERY\_PREFERENCE 71  
INDEX\_PREFERENCE 71  
JOIN\_ALGORITHM\_PREFERENCE 71

MAX\_HASH\_ROWS 71

#### Options, Query Plans

INDEX\_ADVISOR 67  
NOEXEC 67  
QUERY\_DETAIL 67  
QUERY\_PLAN 67  
QUERY\_PLAN\_AFTER\_RUN 67  
QUERY\_PLAN\_AS\_HTML 67  
QUERY\_PLAN\_AS\_HTML\_DIRECTORY 67  
QUERY\_PLAN\_TEXT\_ACCESS 67  
QUERY\_PLAN\_TEXT\_CACHING 67  
QUERY\_TIMING 67

#### ORDER BY Clause 65

OS\_FILE\_CACHE\_BUFFERING 22

OS\_FILE\_CACHE\_BUFFERING\_TEMPDB 22

#### Overhead

Buffer Cache 9

### P

#### Page Size

Block Size 12  
Data Compression 12  
Default Size 12  
Determining 12  
Memory, Saving 12  
Reducing Memory 12

#### Paging 60

Paging and Disk Swapping 60

Partitioned Table 55

Partitions 24

#### Performance

Monitoring And Tuning 28

#### performance

balancing I/O 24  
consideration 3  
definition 3  
designing for 3

#### Performance

Choosing Correct Index Type 41  
Restricting Concurrent Queries 16  
Subqueries 66

Performance Problems, Isolating 59

PREFETCH\_BUFFER\_LIMIT 20

Prefetched Cache Pages 20

#### Prefetched Rows

Controlling 21

PRIMARY KEY 42

Primary Keys 47

- Procedure Profiling
  - Procedures 28
- Procedures, System
  - sp\_iqcolumnuse 72
  - sp\_iqindexuse 72
  - sp\_iqtableuse 72
  - sp\_iqunusedcolumn 72
  - sp\_iqunusedindex 72
  - sp\_iqunusedtable 72
  - sp\_iqworkmon 72
- process threading model 5
- Pushdown Join 55
- Q**
- Queries
  - Caching Methods 66
  - Condition Hints 71
  - Controlling 71
  - Delete Operations 73
  - HG Delete Operations 73
  - Joins 71
  - Limiting By Row 18
  - Optimizer Simplifications 71
  - Optimizing 41, 71
  - ORDER BY Performance 65
  - Query Plans 69
  - Query Priority Options 70
  - Query Processing 69
  - Restricting Concurrent 16
  - Setting Time Limits 70
  - TEXT Delete Operations 75
  - WD Delete Operations 74
  - Workload Monitoring 72
- Queries,
  - Optimizing 65
  - Structuring 65
- Query Evaluation Options 67
  - INDEX\_ADVISOR 67
  - NOEXEC 67
  - QUERY\_DETAIL 67
  - QUERY\_PLAN 67
  - QUERY\_PLAN\_AFTER\_RUN 67
  - QUERY\_PLAN\_AS\_HTML 67
  - QUERY\_PLAN\_AS\_HTML\_DIRECTORY 67
  - QUERY\_PLAN\_TEXT\_ACCESS 67
  - QUERY\_PLAN\_TEXT\_CACHING 67
  - QUERY\_TIMING 67
- query execution
  - distributed 39
- Query Optimization Options
  - AGGREGATION\_ALGORITHM\_PREFERENCE 71
  - DEFAULT\_HAVING\_SELECTIVITY 71
  - DEFAULT\_LIKE\_MATCH\_SELECTIVITY 71
  - DEFAULT\_LIKE\_RANGE\_SELECTIVITY 71
  - EARLY\_PREDICATE\_EXECUTION 71
  - IN\_SUBQUERY\_PREFERENCE 71
  - INDEX\_PREFERENCE 71
  - JOIN\_ALGORITHM\_PREFERENCE 71
  - MAX\_HASH\_ROWS 71
- Query Plans
  - Generating 66
  - Generating Without Executing 67
  - LOAD Evaluation Plans 66
  - Query Evaluation Options 67
  - Query Evaluation Plans 66
  - Using 69
- Query Plans, Options
  - INDEX\_ADVISOR 67
  - NOEXEC 67
  - QUERY\_DETAIL 67
  - QUERY\_PLAN 67
  - QUERY\_PLAN\_AFTER\_RUN 67
  - QUERY\_PLAN\_AS\_HTML 67
  - QUERY\_PLAN\_AS\_HTML\_DIRECTORY 67
  - QUERY\_PLAN\_TEXT\_ACCESS 67
  - QUERY\_PLAN\_TEXT\_CACHING 67
  - QUERY\_TIMING 67
- Query Priority Options 70
- query processing
  - monitoring 72
- Query Processing
  - Controlling 69
- query server
  - balancing loads 40
- QUERY\_PLAN\_TEXT\_ACCESS 69
- QUERY\_PLAN\_TEXT\_CACHING 69
- R**
- Random File Access 26
- Raw devices 24
- Raw Partitions
  - File Systems 9
  - Memory Use 9

# Index

- Required Memory
  - Backup 9
  - Database Validation 9
  - Dropping Leaked Blocks 9
  - Multuser Access 9
  - Raw Partitions 9
  - Thread Stacks 9
- resource use 39
  - load balancing 40
  - multiplex disk space 39
  - network performance 6
- Resource Use
  - Indexing 41
  - Loading with UNION ALL 54
- resource use options
  - setting available CPUs 5
- Resource Use Options 14
  - Forcing Non-scrolling Cursors 18
  - Limiting Cursors 19
  - Limiting Dbspace Use 17
  - Limiting Queries By Row 18
  - Limiting Statements 20
  - Prefetched Rows 21
  - Prefetching Cache Pages 20
  - Restricting Concurrent Queries 16
  - Typical Usage 14
- resources
  - multiplex 39
- response time 3
- S**
- Schema Design
  - Denormalization 53
  - Foreign Keys 47
  - Hash Partitioning 56
  - HG Index Loads 44
  - Indexing 41
  - Join Column 46
  - Large Object Storage 51
  - LONG VARBINARY 50
  - LONG VARCHAR 50
  - Multi-Column Indexes 45
  - Null Values 49
  - Primary Keys 47
  - Proper Data Type Sizing 48
  - Simple Index Selection Criteria 43
  - Temporary Tables 52
  - UNION ALL 55
  - Unsigned Data Types 49
  - Using Indexes 42
- Sequential Disk I/O 26
- Sequential File Access 26
- Server configuration
  - Memory 9
- Server Memory
  - Heap Memory 9
  - Limits 9
  - Shared Memory 9
- Server Statistics 30
- sp\_iqcolumnuse 72
- sp\_iqindexuse 72
- sp\_iqtableuse 72
- sp\_iqunusedcolumn 72
- sp\_iqunusedindex 72
- sp\_iqunusedtable 72
- sp\_iqworkmon 72
- Startup Parameters 15
  - iqwmem 13
  - iqmc 11
  - iqtc 11
- Statements
  - Limiting Statements 20
- Stored Procedures
  - Viewing Profiling Data 28
- Structuring Queries
  - Caching Methods 66
  - Improving Performance 66
- Subqueries
  - Flattening 66
  - Performance 66
- Subquery Performance
  - Improving Performance 66
- SUBQUERY\_CACHING\_PREFERENCE 66
- SUBQUERY\_FLATTENING\_PERCENT 66
- SUBQUERY\_FLATTENING\_PREFERENCE 66
- Swap Files 60
- Swapping 60
- Sweeper Threads 23
- SWEEPER\_THREADS\_PERCENT 23
- System Procedures
  - sp\_iqcolumnuse 72
  - sp\_iqindexuse 72
  - sp\_iqtableuse 72
  - sp\_iqunusedcolumn 72
  - sp\_iqunusedindex 72
  - sp\_iqunusedtable 72
  - sp\_iqworkmon 72



- system resources
  - performance considerations 3
- System Resources
  - Resource Use Options 14

## T

- Tables
  - Collapsing 41
  - Joining 41
- Temporary Tables 52
- TEXT Delete Operations 75
- Thrashing and Query Execution 62
- Thread Stacks
  - Memory 9
- Threads
  - Buffer Caches 23
- throughput 3
- TIME indexes 42, 43
- Transaction log
  - Truncating 27
- Troubleshooting 59
  - Catalog File Growth 62
  - Common performance issues 60
  - Diagnostic Tools 59
  - Index and Row Fragmentation 61
  - Paging and Disk Swapping 60
  - Performance Problems, Isolating 59
  - Thrashing and Query Execution 62
- Truncating
  - Transaction log 27
- Tuning
  - Performance 28
- Tuning Options
  - Cache Partitions 23
  - File System Buffering 22
  - Limiting Number of Statements 19, 20
  - Limiting Queries by Rows Returned 18
  - Limiting Query Temp Space 17
  - Non-Scrolling Cursors 18

- Optimizing for Typical Usage 14
- Optimizing for Users 15
- Prefetched Rows 21
- Prefetching Cache Pages 20
- Restricting Concurrent Queries 16

## U

- UNION ALL
  - Loading 54
  - Rules 55
  - View Performance 55
  - Views 55
- UNIQUE CONSTRAINT 42
- UNIQUE HG 42
- Unsigned Data Types 49
- USER\_RESOURCE\_RESERVATION 14
- Using Indexes
  - CMP 42
  - DATE 42
  - DTTM 42
  - HG 42
  - HNG 42
  - LF 42
  - PRIMARY KEY 42
  - TIME 42
  - UNIQUE CONSTRAINT 42
  - UNIQUE HG 42
  - Using Indexes 42

## W

- WASH\_AREA\_BUFFERS\_PERCENT 23
- WD Delete Operations 74
- WD indexes 42, 43
- Wired Memory
  - iqwmem switch 13
- Workload Monitoring 72

