

SYBASE®

Connecting to Your Database

InfoMaker®

11.5

DOCUMENT ID: DC37791-01-1150-01

LAST REVISED: September 2008

Copyright © 2008 by Sybase, Inc. All rights reserved.

This publication pertains to Sybase software and to any subsequent release until otherwise indicated in new editions or technical notes. Information in this document is subject to change without notice. The software described herein is furnished under a license agreement, and it may be used or copied only in accordance with the terms of that agreement.

To order additional documents, U.S. and Canadian customers should call Customer Fulfillment at (800) 685-8225, fax (617) 229-9845.

Customers in other countries with a U.S. license agreement may contact Customer Fulfillment via the above fax number. All other international customers should contact their Sybase subsidiary or local distributor. Upgrades are provided only at regularly scheduled software release dates. No part of this publication may be reproduced, transmitted, or translated in any form or by any means, electronic, mechanical, manual, optical, or otherwise, without the prior written permission of Sybase, Inc.

Sybase trademarks can be viewed at the Sybase trademarks page at <http://www.sybase.com/detail?id=1011207>. Sybase and the marks listed are trademarks of Sybase, Inc. ® indicates registration in the United States of America.

Java and all Java-based marks are trademarks or registered trademarks of Sun Microsystems, Inc. in the U.S. and other countries.

Unicode and the Unicode Logo are registered trademarks of Unicode, Inc.

All other company and product names mentioned may be trademarks of the respective companies with which they are associated.

Use, duplication, or disclosure by the government is subject to the restrictions set forth in subparagraph (c)(1)(ii) of DFARS 52.227-7013 for the DOD and as set forth in FAR 52.227-19(a)-(d) for civilian agencies.

Sybase, Inc., One Sybase Drive, Dublin, CA 94568.

Contents

About This Book	ix
------------------------------	-----------

PART 1 INTRODUCTION TO DATABASE CONNECTIONS

CHAPTER 1	Understanding Data Connections	3
	How to find the information you need	3
	Accessing data in InfoMaker	4
	Accessing the EAS Demo DB	5
	Using database profiles	6
	About creating database profiles	6
	Creating a database profile	9
	What to do next	10

PART 2 WORKING WITH STANDARD DATABASE INTERFACES

CHAPTER 2	Using the ODBC Interface	13
	About the ODBC interface	13
	What is ODBC?	14
	Using ODBC in InfoMaker	15
	Components of an ODBC connection	15
	Types of ODBC drivers	17
	Ensuring the proper ODBC driver conformance levels	19
	Obtaining ODBC drivers	20
	Getting help with ODBC drivers	20
	Preparing ODBC data sources	21
	Defining ODBC data sources	22
	How InfoMaker accesses the data source	22
	Defining multiple data sources for the same data	25
	Displaying Help for ODBC drivers	25
	Selecting an ODBC translator	26
	Defining the ODBC interface	26
	Sybase SQL Anywhere	27

	Supported versions for SQL Anywhere	27
	Basic software components for SQL Anywhere	27
	Preparing to use the SQL Anywhere data source	28
	Defining the SQL Anywhere data source	29
	Support for Transact-SQL special timestamp columns	31
	What to do next	32
CHAPTER 3	Using the JDBC Interface.....	33
	About the JDBC interface.....	33
	What is JDBC?	33
	Components of a JDBC connection	34
	JDBC registry entries	36
	Supported versions for JDBC.....	37
	Supported JDBC datatypes.....	37
	Preparing to use the JDBC interface.....	37
	Defining the JDBC interface.....	39
CHAPTER 4	Using the OLE DB Interface.....	41
	About the OLE DB interface.....	41
	What is OLE DB?	42
	Components of an OLE DB connection	44
	Obtaining OLE DB data providers	44
	Supported versions for OLE DB	45
	Preparing to use the OLE DB interface.....	45
	Defining the OLE DB interface	47
PART 3	WORKING WITH NATIVE DATABASE INTERFACES	
CHAPTER 5	Using Native Database Interfaces	51
	About native database interfaces.....	51
	Components of a database interface connection.....	52
	Using a native database interface.....	53
CHAPTER 6	Using Adaptive Server Enterprise.....	55
	Supported versions for Adaptive Server	55
	Supported Adaptive Server datatypes	56
	Basic software components for Adaptive Server	58
	Preparing to use the Adaptive Server database	59
	Defining the Adaptive Server database interface.....	61
	Using Open Client security services	62
	What are Open Client security services?	62

Requirements for using Open Client security services.....	62
Security services DBParm parameters	63
Using Open Client directory services	64
What are Open Client directory services?	64
Requirements for using Open Client directory services	65
Specifying the server name with Open Client directory services	66
Directory services DBParm parameters	67
Using PRINT statements in Adaptive Server stored procedures ...	67
Creating a report based on a cross-database join	67
Installing stored procedures in Adaptive Server databases	68
What are the InfoMaker stored procedure scripts?	68
How to run the scripts.....	71

CHAPTER 7

Using Informix.....	75
Supported versions for Informix	75
Supported Informix datatypes	76
Informix DateTime datatype	76
Informix Time datatype	77
Informix Interval datatype	77
Features supported by the I10 interface	77
Accessing Unicode data	77
Assigning an owner to the InfoMaker catalog tables.....	79
Support for long object names	79
Renaming an index	79
SQL statement caching	79
Creating and dropping indexes without locking.....	80
Column-level encryption.....	81
Using multiple OUT parameters in user-defined routines	81
Basic software components for Informix	82
Preparing to use the Informix database	82
Defining the Informix database interface.....	84
Specifying the server name	84

CHAPTER 8

Using Microsoft SQL Server	87
Supported versions for SQL Server	87
Supported SQL Server datatypes	88
Basic software components for Microsoft SQL Server.....	89
Preparing to use the SQL Server database	89
Defining the SQL Server database interface.....	91
Migrating from the MSS or OLE DB database interfaces.....	92
SQL Server 2005 features	95
SQL Server 2008 features	95
New database parameters	96

Support for new datatypes in SQL Server 2008..... 97
T-SQL enhancements 101
Unsupported SQL Server 2008 features 103
Notes on using the SNC interface 103

CHAPTER 9 **Using Oracle..... 105**
 Supported versions for Oracle 105
 Supported Oracle datatypes 106
 Basic software components for Oracle 108
 Preparing to use the Oracle database 109
 Defining the Oracle database interface..... 113
 Specifying the Oracle server connect descriptor..... 113
 Using Oracle stored procedures as a data source 114
 What is an Oracle stored procedure?..... 114
 What you can do with Oracle stored procedures 114
 Using Oracle stored procedures with result sets..... 115
 Using a large-object output parameter 118
 Using Oracle user-defined types 118
 ORA driver support for Oracle 11g features..... 120

CHAPTER 10 **Using DirectConnect 123**
 Using the DirectConnect interface 123
 Connecting through the DirectConnect middleware product. 124
 Connecting through the Open ServerConnect middleware product
 124
 Selecting the type of connection 125
 Supported versions for the DirectConnect interface 125
 Supported DirectConnect interface datatypes 126
 Basic software components for the DirectConnect interface 127
 Preparing to use the database with DirectConnect..... 128
 Defining the DirectConnect interface 131
 Creating the extended attribute system tables in DB2 databases 132
 Creating the extended attribute system tables 132
 Using the DB2SYSPB.SQL script 133

PART 4 **WORKING WITH DATABASE CONNECTIONS**

CHAPTER 11 **Managing Database Connections 137**
 About database connections..... 137
 When database connections occur 138
 Using database profiles..... 139
 Connecting to a database 140

Selecting a database profile	140
What happens when you connect	141
Specifying passwords in database profiles	142
Maintaining database profiles	143
Sharing database profiles	143
About shared database profiles.....	143
Setting up shared database profiles.....	144
Using shared database profiles to connect	145
Making local changes to shared database profiles	146
Maintaining shared database profiles.....	147
Importing and exporting database profiles	147
About the InfoMaker extended attribute system tables	148
Logging in to your database for the first time	149
Displaying the InfoMaker extended attribute system tables ..	149
Contents of the extended attribute system tables	151
Controlling system table access.....	152

CHAPTER 12	Setting Additional Connection Parameters	155
	Basic steps for setting connection parameters	155
	About the Database Profile Setup dialog box	156
	Setting database parameters	157
	Setting database parameters in the development environment	157
	Setting database preferences	158
	Setting database preferences in the development environment ..	158

CHAPTER 13	Troubleshooting Your Connection.....	163
	Overview of troubleshooting tools	163
	Using the Database Trace tool.....	164
	About the Database Trace tool.....	164
	Starting the Database Trace tool.....	168
	Stopping the Database Trace tool	169
	Using the Database Trace log.....	169
	Sample Database Trace output.....	171
	Using the ODBC Driver Manager Trace tool	173
	About ODBC Driver Manager Trace.....	173
	Starting ODBC Driver Manager Trace.....	174
	Stopping ODBC Driver Manager Trace	175
	Viewing the ODBC Driver Manager Trace log.....	176
	Sample ODBC Driver Manager Trace output.....	176
	Using the JDBC Driver Manager Trace tool	177
	About JDBC Driver Manager Trace.....	177
	Starting JDBC Driver Manager Trace.....	178

Stopping JDBC Driver Manager Trace..... 179
Viewing the JDBC Driver Manager Trace log..... 180

PART 5

APPENDIX

APPENDIX A **Adding Functions to the PBODB115 Initialization File 183**
 About the PBODB115 initialization file 183
 Adding functions to PBODB115.INI 184
 Adding functions to an existing section in the file..... 184
 Adding functions to a new section in the file 187

Index 191

About This Book

Audience	This book is for anyone who uses InfoMaker® to connect to a database. It assumes that you are familiar with the database you are using and have installed the server and client software required to access the data.
How to use this book	This book describes how to connect to a database in InfoMaker by using a standard or native database interface. It gives procedures for preparing, defining, establishing, maintaining, and troubleshooting your database connections. For an overview of the steps you need to take, see “Basic connection procedure” on page 3.
Related documents	For detailed information about supported database interfaces, DBParm parameters, and database preferences, see the Database Connectivity section in the online Help. For a complete list of InfoMaker documentation, see InfoMaker <i>Getting Started</i> .
Other sources of information	<p>Use the Sybase® Getting Started CD, the SyBooks™ CD, and the Sybase Product Manuals Web site to learn more about your product:</p> <ul style="list-style-type: none">• The Getting Started CD contains release bulletins and installation guides in PDF format, and may also contain other documents or updated information not included on the SyBooks CD. It is included with your software. To read or print documents on the Getting Started CD, you need Adobe Acrobat Reader, which you can download at no charge from the Adobe Web site using a link provided on the CD.• The SyBooks CD contains product manuals and is included with your software. The Eclipse-based SyBooks browser allows you to access the manuals in an easy-to-use, HTML-based format. <p>Some documentation may be provided in PDF format, which you can access through the PDF directory on the SyBooks CD. To read or print the PDF files, you need Adobe Acrobat Reader.</p> <p>Refer to the <i>SyBooks Installation Guide</i> on the Getting Started CD, or the <i>README.txt</i> file on the SyBooks CD for instructions on installing and starting SyBooks.</p>

- The Sybase Product Manuals Web site is an online version of the SyBooks™ CD that you can access using a standard Web browser. In addition to product manuals, you will find links to EBFs/Maintenance, Technical Documents, Case Management, Solved Cases, newsgroups, and the Sybase Developer Network.

To access the Sybase Product Manuals Web site, go to Product Manuals at <http://www.sybase.com/support/manuals/>.

Conventions

The formatting conventions used in this manual are:

Formatting example	Indicates
Retrieve and Update	When used in descriptive text, this font indicates: <ul style="list-style-type: none"> • Command, function, and method names • Keywords such as true, false, and null • Datatypes such as integer and char • Database column names such as emp_id and f_name • User-defined objects such as dw_emp or w_main
<i>variable or file name</i>	When used in descriptive text and syntax descriptions, oblique font indicates: <ul style="list-style-type: none"> • Variables, such as <i>myCounter</i> • Parts of input text that must be substituted, such as <i>pblname.pbd</i> • File and path names
File>Save	Menu names and menu items are displayed in plain text. The greater than symbol (>) shows you how to navigate menu selections. For example, File>Save indicates “select Save from the File menu.”
dw_1.Update()	Monospace font indicates: <ul style="list-style-type: none"> • Information that you enter in a dialog box or on a command line • Sample script fragments • Sample output fragments

If you need help

Each Sybase installation that has purchased a support contract has one or more designated people who are authorized to contact Sybase Technical Support. If you cannot resolve a problem using the manuals or online help, please have the designated person contact Sybase Technical Support or the Sybase subsidiary in your area.

PART 1

Introduction to Database Connections

This part introduces data connections in InfoMaker. It helps you understand how to connect to a database in the InfoMaker development environment.

About this chapter

This chapter gives an overview of the concepts and procedures for connecting to a database in the InfoMaker development environment.

Contents

Topic	Page
How to find the information you need	3
Accessing data in InfoMaker	4
Accessing the EAS Demo DB	5
Using database profiles	6
What to do next	10

How to find the information you need

This book describes how to connect to your database in the InfoMaker development environment.

Basic connection procedure

The following table gives an overview of the connection procedure and indicates where you can find detailed information about each step.

Table 1-1: Basic connection procedure

Step	Action	Details	See
1	(Optional) Get an introduction to database connections in InfoMaker	If necessary, learn more about how InfoMaker connects to a database	Chapter 1 (this chapter)
2	Prepare to use the data source or database before connecting to it for the first time in InfoMaker	Install the required network, database server, and database client software and verify that you can connect to the database	<p><i>For ODBC data sources:</i> Chapter 2, “Using the ODBC Interface”</p> <p><i>For JDBC data sources:</i> Chapter 3, “Using the JDBC Interface”</p> <p><i>For OLE DB data sources:</i> Chapter 4, “Using the OLE DB Interface”</p> <p><i>For native database interfaces:</i> Chapter 5, “Using Native Database Interfaces”</p>

Step	Action	Details	See
3	Install the driver, database provider, or native database interface required to access your data	Install the ODBC driver, OLE DB data provider, or native database interface	For a list of what is supported on your platform: “Supported Database Interfaces” in online Help
4	Define the data source (ODBC connections and some OLE DB drivers)	Create the required configuration for a data source accessed through ODBC	<i>For ODBC data sources:</i> Chapter 2, “Using the ODBC Interface”
5	Define the database interface	Create the database profile	<i>For ODBC data sources:</i> Chapter 2, “Using the ODBC Interface” <i>For JDBC data sources:</i> Chapter 3, “Using the JDBC Interface” <i>For OLE DB data sources:</i> Chapter 4, “Using the OLE DB Interface” <i>For native database interfaces:</i> Chapter 5, “Using Native Database Interfaces”
6	Connect to the data source or database	Access the data in InfoMaker	Chapter 11, “Managing Database Connections”
7	(Optional) Set additional connection parameters	If necessary, set database parameters and database preferences to fine-tune your database connection and take advantage of DBMS-specific features that your interface supports	<i>For procedures:</i> Chapter 12, “Setting Additional Connection Parameters” <i>For database parameter and preference descriptions:</i> online Help
8	(Optional) Troubleshoot the data connection	If necessary, use the trace tools to troubleshoot problems with your connection	Chapter 13, “Troubleshooting Your Connection”

Accessing data in InfoMaker

There are several ways to access data in the InfoMaker development environment:

- Through one of the standard database interfaces such as ODBC, JDBC, or OLE DB
- Through one of the native database interfaces

Standard database interfaces

A standard database interface communicates with a database through a standard-compliant driver (in the case of ODBC and JDBC) or data provider (in the case of OLE DB). The standard-compliant driver or data provider translates the abstract function calls defined by the standard's API into calls that are understood by a specific database. To use a standard interface, you need to install the standard's API and a suitable driver or data provider. Then, install the standard database interface you want to use to access your DBMS by selecting the interface in the InfoMaker Setup program.

InfoMaker currently supports the following standard interfaces:

- Open Database Connectivity (ODBC)
- Java Database Connectivity (JDBC)
- Microsoft's Universal Data Access Component OLE DB

Native database interfaces

A native database interface communicates with a database through a direct connection. It communicates to a database using that database's native API.

To access data through one of the native database interfaces, you must first install the appropriate database software on the server and client workstations at your site. Then, install the native database interface that accesses your DBMS by selecting the interface in the InfoMaker Setup program.

For example, if you have the appropriate Sybase Adaptive Server® Enterprise server and client software installed, you can access the database by installing the Adaptive Server Enterprise database interface.

InfoMaker with other Sybase products

If your version of InfoMaker was provided with another Sybase product, see the Help for that product for information about database connectivity features.

Accessing the EAS Demo DB

InfoMaker includes a standalone SQL Anywhere® database called the EAS Demo DB. Unless you clear this option in the setup program, the database is installed automatically. You access tables in the EAS Demo DB when you use the InfoMaker tutorial.

A SQL Anywhere database is considered an ODBC data source, because you access it with the SQL Anywhere ODBC driver.

Using database profiles

What is a database profile?	A database profile is a named set of parameters stored in your system registry that defines a connection to a particular database in the InfoMaker development environment. You must create a database profile for each data connection.
What you can do	Using database profiles is the easiest way to manage data connections in the InfoMaker development environment. For example, you can: <ul style="list-style-type: none">• Select a database profile to connect to or switch between databases• Edit a database profile to customize a connection• Delete a database profile if you no longer need to access that data• Import and export database profiles to share connection parameters quickly
For more information	For instructions on using database profiles, see Chapter 11, “Managing Database Connections.”

About creating database profiles

Using the Database painter to create database profiles

The Database painter is an optional InfoMaker painter. If the Database painter is installed, you can also create database profiles from the Database painter’s Objects view. However, opening the Database painter to define profiles and/or connect to a database uses more system resources than using the Database Profiles dialog box.

Database Profiles dialog box

The Database Profiles dialog box uses an easy-to-navigate tree control format to display your installed database interfaces and defined database profiles. You can create, edit, and delete database profiles from this dialog box.

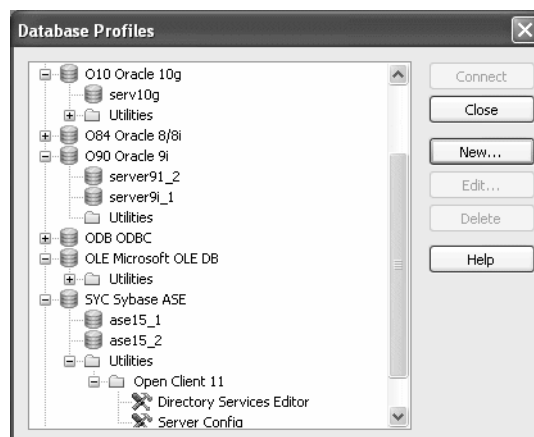

When you run the InfoMaker Setup program, it updates the Vendors list in the PowerBuilder® section in the HKEY_LOCAL_MACHINE registry key with the interfaces you install. The Database Profiles dialog box displays the same interfaces that appear in the Vendors list.

Where the Vendors list is stored

The *Sybase\PowerBuilder\11.5\Vendors* key in *HKEY_LOCAL_MACHINE\SOFTWARE* is used for InfoMaker as well as PowerBuilder.

Database Profile Setup dialog box

For detailed instructions on using the Database Profiles dialog box to connect to a database and manage your profiles, see Chapter 11, “Managing Database Connections.”

Each database interface has its own Database Profile Setup dialog box where you can set interface-specific connection parameters. For example, if you install the Adaptive Server Enterprise ASE interface and then select it and click New in the Database Profiles dialog box, the Database Profile Setup - Adaptive Server Enterprise dialog box displays, containing settings for the connection options that apply to this interface.

Preview tab unavailable in InfoMaker

PowerScript® connection syntax does not apply to InfoMaker. Therefore, the Database Profile Setup dialog box in InfoMaker does *not* include a Preview tab for copying PowerScript connection syntax into a script.

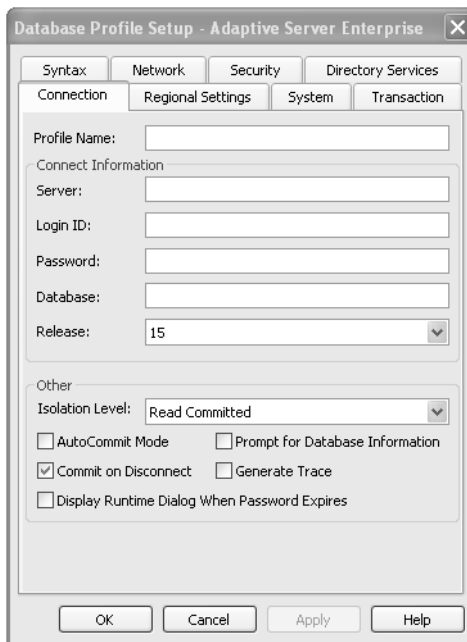

The Database Profile Setup dialog box groups similar connection parameters on the same tab page and lets you easily set their values by using check boxes, drop-down lists, and text boxes. Basic (required) connection parameters are on the Connection tab page, and additional connection options (DBParm parameters and SQLCA properties) are on the other tab pages.

Supplying sufficient information in the Database Profile Setup dialog box

For some database interfaces, you might not need to supply values for all boxes in the Database Profile Setup dialog box. If you supply the profile name and click OK, InfoMaker displays a series of dialog boxes to prompt you for additional information when you connect to the database.

This information can include:

- User ID or login ID
- Password or login password
- Database name
- Server name

For some databases, supplying only the profile name does not give InfoMaker enough information to prompt you for additional connection values. For these interfaces, you must supply values for all applicable boxes in the Database Profile Setup dialog box.

For information about the values you should supply for your connection, click Help in the Database Profile Setup dialog box for your interface.

Creating a database profile

To create a new database profile for a database interface, you must complete the Database Profile Setup dialog box for the interface you are using to access the database.

❖ **To create a database profile for a database interface:**

- 1 Click the Database Profile button in the PowerBar.

The Database Profiles dialog box displays, listing your installed database interfaces. To see a list of database profiles defined for a particular interface, click the plus sign to the left of the interface name or double-click the interface name to expand the list.

- 2 Highlight an interface name and click New.

The Database Profile Setup dialog box for the selected interface displays. For example, if you select the SYC interface, the Database Profile Setup - Adaptive Server Enterprise dialog box displays.

Client software and interface must be installed

To display the Database Profile Setup dialog box for your interface, the required client software and native database interface must be properly installed and configured. For specific instructions for your database interface, see the chapter on using the interface.

- 3 On the Connection tab page, type the profile name and supply values for any other basic parameters your interface requires to connect.

For information about the basic connection parameters for your interface and the values you should supply, click Help.

About the DBMS identifier

You do *not* need to specify the DBMS identifier in a database profile. When you create a new profile for any installed database interface, InfoMaker generates the correct DBMS connection syntax for you.

- 4 (Optional) On the other tab pages, supply values for any additional connection options (DBParm parameters and SQLCA properties) to take advantage of DBMS-specific features that your interface supports.

For information about the additional connection parameters for your interface and the values you should supply, click Help.

- 5 Click OK to save your changes and close the Database Profile Setup dialog box. (To save your changes on a particular tab page *without* closing the dialog box, click Apply.)

The Database Profiles dialog box displays, with the new profile name highlighted under the appropriate interface. The database profile values are saved in the system registry in

HKEY_CURRENT_USER\Software\Sybase\PowerBuilder\11.5\DatabaseProfiles\PowerBuilder.

You can look at the registry entry or export the profile as described in “Importing and exporting database profiles” on page 147 to see the settings you made. The NewLogic parameter is set to True by default. This setting specifies that the password is encrypted using Unicode encoding.

What to do next

For instructions on preparing to use and then defining an ODBC data source, see Chapter 2, “Using the ODBC Interface.”

For instructions on preparing to use and then defining a JDBC database interface, see Chapter 3, “Using the JDBC Interface.”

For instructions on preparing to use and then defining an OLE DB data provider, see Chapter 4, “Using the OLE DB Interface.”

For instructions on preparing to use and then defining a native database interface, see Chapter 5, “Using Native Database Interfaces.”

PART 2

Working with Standard Database Interfaces

This part describes how to set up and define database connections accessed through one of the standard database interfaces.

Using the ODBC Interface

About this chapter

This chapter gives an introduction to the ODBC interface and then describes how to prepare to use the data source, how to define the data source, and how to define the ODBC database profile. It also describes how to use the Sybase SQL Anywhere ODBC driver.

Contents

Topic	Page
About the ODBC interface	13
Preparing ODBC data sources	21
Defining ODBC data sources	22
Defining the ODBC interface	26
Sybase SQL Anywhere	27

For more information

This chapter gives general information about preparing to use and defining each ODBC data source. For more detailed information:

- Use the online Help provided by the driver vendor, as described in “Displaying Help for ODBC drivers” on page 25. This Help provides important details about using the data source.
- Check to see if there is a technical document that describes how to connect to your ODBC data source. Any updated information about connectivity issues is available from the Sybase Support and Downloads Web site at <http://www.sybase.com/support>.

About the ODBC interface

You can access a wide variety of ODBC data sources in InfoMaker. This section describes what you need to know to use ODBC connections to access your data in InfoMaker.

What is ODBC?

The ODBC API

Open Database Connectivity (ODBC) is a standard application programming interface (API) developed by Microsoft. It allows a single application to access a variety of data sources for which ODBC-compliant drivers exist. The application uses Structured Query Language (SQL) as the standard data access language.

The ODBC API defines the following:

- A library of ODBC function calls that connect to the data source, execute SQL statements, and retrieve results
- A standard way to connect and log in to a DBMS
- SQL syntax based on the X/Open and SQL Access Group (SAG) CAE specification (1992)
- A standard representation for datatypes
- A standard set of error codes

Accessing ODBC data sources

Applications that provide an ODBC interface, like InfoMaker, can access data sources for which an ODBC driver exists. An **ODBC data source driver** is a dynamic link library (DLL) that implements ODBC function calls. The application invokes the ODBC driver to access a particular data source.

Accessing Unicode data

Using the ODBC interface, InfoMaker can connect, save, and retrieve data in both ANSI/DBCS and Unicode databases but does not convert data between Unicode and ANSI/DBCS. When character data or command text is sent to the database, InfoMaker sends a Unicode string. The driver must guarantee that the data is saved as Unicode data correctly. When InfoMaker retrieves character data, it assumes the data is Unicode.

A Unicode database is a database whose character set is set to a Unicode format, such as UTF-8, UTF-16, UCS-2, or UCS-4. All data must be in Unicode format, and any data saved to the database must be converted to Unicode data implicitly or explicitly.

A database that uses ANSI (or DBCS) as its character set might use special datatypes to store Unicode data. Columns with these datatypes can store *only* Unicode data. Any data saved into such a column must be converted to Unicode explicitly. This conversion must be handled by the database server or client.

Using ODBC in InfoMaker

What you can do

The following ODBC connectivity features are available in InfoMaker:

- Connect to a SQL Anywhere standalone database (including the EAS Demo DB) using the SQL Anywhere ODBC driver and the ODBC interface
- Create and delete local SQL Anywhere databases
For instructions, see the *Users Guide*.
- Use Level 1 or later ODBC-compliant drivers to access your data
See “Obtaining ODBC drivers” on page 20.
- Use Microsoft’s ODBC Data Source Administrator to define ODBC data sources
See “Defining ODBC data sources” on page 22.

Components of an ODBC connection

How an ODBC connection is made

When you access an ODBC data source in InfoMaker, your connection goes through several layers before reaching the data source. It is important to understand that each layer represents a separate component of the connection, and that each component might come from a different vendor.

Because ODBC is a standard API, InfoMaker uses the same interface to access every ODBC data source. As long as a driver is ODBC compliant, InfoMaker can access it through the ODBC interface to the ODBC Driver Manager. The development environment and the ODBC interface work together as the application component.

Figure 2-1 shows the general components of an ODBC connection.

Figure 2-1: Components of an ODBC connection

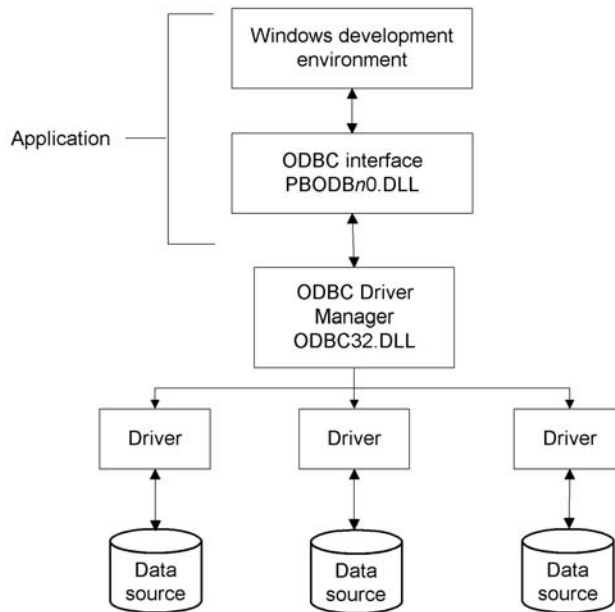

Component descriptions

Table 2-1 gives the provider and a brief description of each ODBC component shown in the diagram.

Table 2-1: Provider and function of ODBC connection components

Component	Provider	What it does
Application	Sybase	<p>Calls ODBC functions to submit SQL statements, catalog requests, and retrieve results from a data source.</p> <p>InfoMaker uses the same ODBC interface to access all ODBC data sources.</p>
ODBC Driver Manager	Microsoft	Installs, loads, and unloads drivers for an application.
Driver	Driver vendor	<p>Processes ODBC function calls, submits SQL requests to a particular data source, and returns results to an application.</p> <p>If necessary, translates an application's request so that it conforms to the SQL syntax supported by the back-end database. See "Types of ODBC drivers" next.</p>

Component	Provider	What it does
Data source	DBMS or database vendor	Stores and manages data for an application. Consists of the data to be accessed and its associated DBMS, operating system, and (if present) network software that accesses the DBMS.

Types of ODBC drivers

When InfoMaker is connected to an ODBC data source, you might see messages from the ODBC driver that include the words *single-tier* or *multiple-tier*. These terms refer to the two types of drivers defined by the ODBC standard.

Single-tier driver

A single-tier ODBC driver processes both ODBC functions and SQL statements. In other words, a single-tier driver includes the data access software required to manage the data source file and catalog tables. An example of a single-tier ODBC driver is the Microsoft Access driver.

Figure 2-2: Single-tier ODBC driver

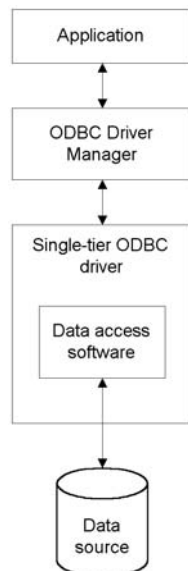

Multiple-tier driver

A multiple-tier ODBC driver processes ODBC functions, but sends SQL statements to the database engine for processing. Unlike the single-tier driver, a multiple-tier driver does not include the data access software required to manage the data directly.

An example of a multiple-tier ODBC driver is the Sybase SQL Anywhere driver.

Figure 2-3: Multi-tier ODBC driver

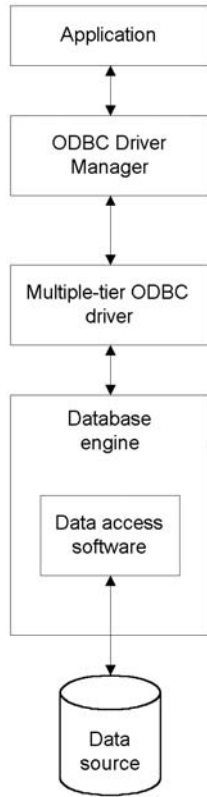

Ensuring the proper ODBC driver conformance levels

You can access data in InfoMaker with ODBC drivers obtained from vendors other than Sybase, such as DBMS vendors.

An ODBC driver obtained from another vendor must meet certain conformance requirements to ensure that it works properly with InfoMaker. This section describes how to make sure your driver meets these requirements.

What are ODBC conformance levels?

InfoMaker can access many data sources for which ODBC-compliant drivers exist. However, ODBC drivers manufactured by different vendors might vary widely in the functions they provide.

To ensure a standard level of compliance with the ODBC interface, and to provide a means by which application vendors can determine whether a specific driver provides the functions they need, ODBC defines conformance levels for drivers in two areas:

- **API** Deals with supported ODBC function calls
- **SQL grammar** Deals with supported SQL statements and SQL datatypes

API conformance levels

ODBC defines three API conformance levels, in order of increasing functionality:

- **Core** A set of core API functions that corresponds to the functions in the ISO Call Level Interface (CLI) and X/Open CLI specification
- **Level 1** Includes all Core API functions and several extended functions usually available in an OLTP relational DBMS
- **Level 2** Includes all Core and Level 1 API functions and additional extended functions

❖ **To ensure the proper ODBC driver API conformance level:**

- Sybase recommends that the ODBC drivers you use with InfoMaker meet *Level 1 or higher* API conformance requirements. However, InfoMaker might also work with drivers that meet Core level API conformance requirements.

SQL conformance levels

ODBC defines three SQL grammar conformance levels, in order of increasing functionality:

- **Minimum** A set of SQL statements and datatypes that meets a basic level of ODBC conformance

- **Core** Includes all Minimum SQL grammar and additional statements and datatypes that roughly correspond to the X/Open and SAG CAE specification (1992)
 - **Extended** Includes all Minimum and Core SQL grammar and an extended set of statements and datatypes that support common DBMS extensions to SQL
- ❖ **To ensure the proper ODBC driver SQL conformance level:**
- Sybase recommends that the ODBC drivers you use with InfoMaker meet *Core or higher* SQL conformance requirements. However, InfoMaker might also work with drivers that meet Minimum level SQL conformance requirements.

Obtaining ODBC drivers

InfoMaker lets you access data with *any* Level 1 or higher ODBC-compliant drivers obtained from a vendor other than Sybase. In most cases, these drivers will work with InfoMaker.

Getting help with ODBC drivers

To ensure that you have up-to-date and accurate information about using your ODBC driver with InfoMaker, get help as needed by doing one or more of the following:

To get help on	Do this
Using the ODBC Data Source Administrator	Click the Help button on each tab.
Completing the ODBC setup dialog box for your driver	Click the Help button (if present) in the ODBC setup dialog box for your driver.
Using SQL Anywhere	See the SQL Anywhere documentation.
Using an ODBC driver obtained from a vendor other than Sybase	See the vendor's documentation for that driver.
Troubleshooting your ODBC connection	Check for a technical document that describes how to connect to your ODBC data source. Updated information about connectivity issues is available on the Sybase Support and Downloads Web site at http://www.sybase.com/support .

Preparing ODBC data sources

The first step in connecting to an ODBC data source is preparing the data source. This ensures that you are able to connect to the data source and use your data in InfoMaker.

You prepare to use a data source *outside* InfoMaker *before* you start the product, define the data source, and connect to it. The requirements differ for each data source, but in general, preparing to use a data source involves the following steps.

❖ **To prepare to use an ODBC data source with InfoMaker:**

- 1 If network software is required to access the data source, make sure it is properly installed and configured at your site and on the client workstation.
- 2 If database software is required, make sure it is properly installed and configured on your computer or network server.
- 3 Make sure the required data files are present on your computer or network server.
- 4 Make sure the names of tables and columns you want to access follow standard SQL naming conventions.

Avoid using blank spaces or database-specific reserved words in table and column names. Be aware of the case-sensitivity options of the DBMS. It is safest to use all uppercase characters when naming tables and columns that you want to access in InfoMaker.

- 5 If your database requires it, make sure the tables you want to access have unique indexes.
- 6 Install both of the following using the InfoMaker Setup program:
 - The ODBC driver that accesses your data source
 - The ODBC interface

Defining ODBC data sources

Each ODBC data source requires a corresponding ODBC driver to access it. When you define an ODBC data source, you provide information about the data source that the driver requires in order to connect to it. Defining an ODBC data source is often called configuring the data source.

After you prepare to use the data source, you must define it using Microsoft's ODBC Data Source Administrator utility. This utility can be accessed from the Control Panel in Windows or InfoMaker's Database painter.

The rest of this section describes what you need to know to define an ODBC data source in order to access it in the InfoMaker development environment.

How InfoMaker accesses the data source

When you access an ODBC data source in InfoMaker, there are several initialization files and registry entries on your computer that work with the ODBC interface and driver to make the connection.

PBODB115 initialization file

Contents

PBODB115.INI is installed in the *Sybase\Shared\PowerBuilder* directory. The first time the user opens InfoMaker, the file is copied to *Local Settings\Application Data\Sybase\InfoMaker 11.5* in the user's profile folder (for example, under *C:\Documents and Settings\username*). This copy is used when running InfoMaker. InfoMaker uses *PBODB115.INI* to maintain access to extended functionality in the back-end DBMS, for which ODBC does not provide an API call. Examples of extended functionality are SQL syntax or DBMS-specific function calls.

Editing

In most cases, you do not need to edit *PBODB115.INI*. In certain situations, however, you might need to add functions to *PBODB115.INI* for your back-end DBMS. Be sure to edit the copy in your user profile folder, not the original copy.

For instructions, see the Appendix, "Adding Functions to the PBODB115 Initialization File."

ODBCINST registry entries

- Contents** The ODBCINST initialization information is located in the *HKEY_LOCAL_MACHINE\SOFTWARE\ODBC\ODBCINST.INI* registry key. When you install an ODBC-compliant driver, *ODBCINST.INI* is automatically updated with a description of the driver.
- This description includes:
- The DBMS or data source associated with the driver
 - The drive and directory of the driver and setup DLLs (for some data sources, the driver and setup DLLs are the same)
 - Other driver-specific connection parameters
- Editing** You do *not* need to edit the registry key directly to modify connection information. If your driver uses the information in the *ODBCINST.INI* registry key, the key is automatically updated when you install the driver. This is true whether the driver is supplied by Sybase or another vendor.

ODBC registry entries

- Contents** ODBC initialization information is located in the *HKEY_CURRENT_USER\SOFTWARE\ODBC\ODBC.INI* registry key. When you define a data source for a particular ODBC driver, the driver writes the values you specify in the ODBC setup dialog box to the *ODBC.INI* registry key.
- The *ODBC.INI* key contains subkeys named for each defined data source. Each subkey contains the values specified for that data source in the ODBC setup dialog box. The values might vary for each data source but generally include the following:
- Database
 - Driver
 - Optional description
 - DBMS-specific connection parameters
- Editing** Do *not* edit the *ODBC* subkey directly to modify connection information. Instead, use a tool designed to define ODBC data sources and the ODBC configuration automatically, such as the ODBC Data Source Administrator.

Database profiles registry entry

Contents	Database profiles for all data sources are stored in the registry in <i>HKEY_CURRENT_USER\SOFTWARE\Sybase\PowerBuilder\11.5\DatabaseProfiles</i> .
Editing	<p>You should <i>not</i> need to edit the profiles directly to modify connection information. These files are updated automatically when InfoMaker creates the database profile as part of the ODBC data source definition.</p> <p>You can also edit the profile in the Database Profile Setup dialog box or complete the Database Preferences dialog box in InfoMaker to specify other connection parameters stored in the registry. (For instructions, see Chapter 12, “Setting Additional Connection Parameters.”)</p>
Example	The following example shows a portion of the database profile for an EAS Demo DB data source:

```
DBMS=ODBC
DBParm=ConnectString='DSN=EAS Demo DB V115
DB;UID=dba;PWD=00c61737'
Prompt=0
```

This registry entry example shows the two most important values in a database profile for an ODBC data source:

- **DBMS** The DBMS value (ODBC) indicates that you are using the ODBC interface to connect to the data source.
- **DBParm** The ConnectString DBParm parameter controls your ODBC data source connection. The connect string *must* specify the DSN (data source name) value, which tells ODBC which data source you want to connect to. When you select a database profile to connect to a data source, ODBC looks in the ODBC.INI registry key for a subkey that corresponds to the data source name in your profile. ODBC then uses the information in the subkey to load the required libraries to connect to the data source. The connect string can also contain the UID (user ID) and PWD (password) values needed to access the data source.

Defining multiple data sources for the same data

When you define an ODBC data source in InfoMaker, each data source name must be unique. You can, however, define multiple data sources that access the same data, as long as the data sources have unique names.

For example, assume that your data source is a SQL Anywhere database located in `C:\SQL Anywhere\SALES.DB`. Depending on your application, you might want to specify different sets of connection parameters for accessing the database, such as different passwords and user IDs.

To do this, you can define two ODBC data sources named `Sales1` and `Sales2` that specify the same database (`C:\SQL Anywhere\SALES.DB`) but use different user IDs and passwords. When you connect to the data source using a profile created for either of these data sources, you are using different connection parameters to access the same data.

Figure 2-4: Using two data sources to access a database

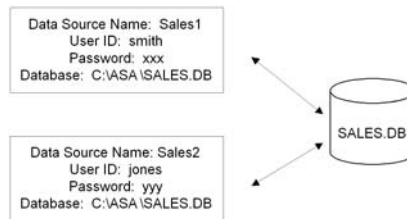

Displaying Help for ODBC drivers

The online Help for ODBC drivers in InfoMaker is provided by the driver vendors. It gives help on:

- Completing the ODBC setup dialog box to define the data source
- Using the ODBC driver to access the data source

Help for any ODBC driver

Use the following procedure to display vendor-supplied Help when you are in the ODBC setup dialog box for ODBC drivers.

❖ **To display Help for any ODBC driver:**

- Click the Help button in the ODBC setup dialog box for your driver.

A Help window displays, describing features in the setup dialog box.

Selecting an ODBC translator

What is an ODBC translator?

Some ODBC drivers allow you to specify a translator when you define the data source. An **ODBC translator** is a DLL that translates data passing between an application and a data source. Typically, translators are used to translate data from one character set to another.

What you do

Follow these steps to select a translator for your ODBC driver.

❖ **To select a translator when using an ODBC driver:**

- 1 In the ODBC setup dialog box for your driver, display the Select Translator dialog box.

The way you display the Select Translator dialog box depends on the driver and Windows platform you are using. Click Help in your driver's setup dialog box for instructions on displaying the Select Translator dialog box.

In the Select Translator dialog box, the translators listed are determined by the values in your *ODBCINST.INI* registry key.

- 2 From the Installed Translators list, select a translator to use.

If you need help using the Select Translator dialog box, click Help.

- 3 Click OK.

The Select Translator dialog box closes and the driver performs the translation.

Defining the ODBC interface

To define a connection through the ODBC interface, you must create a database profile by supplying values for at least the basic connection parameters in the Database Profile Setup - ODBC dialog box. You can then select this profile at any time to connect to your data source in the development environment.

For information on how to define a database profile, see “Using database profiles” on page 6.

Sybase SQL Anywhere

This section describes how to prepare and define a Sybase SQL Anywhere data source in order to connect to it using the SQL Anywhere ODBC driver.

Name change

For versions 6 through 9, the SQL Anywhere database server was called Adaptive Server® Anywhere (ASA).

SQL Anywhere includes two database servers—a personal database server and a network database server. For information about using Sybase SQL Anywhere, see the SQL Anywhere documentation.

Supported versions for SQL Anywhere

The SQL Anywhere ODBC driver supports connection to local and remote databases created with the following:

- InfoMaker running on your computer
- SQL Anywhere version 11
- SQL Anywhere version 10.x
- ASA version 9.x
- ASA version 8.x
- ASA version 7.x
- ASA version 6.x
- SQL Anywhere version 5.x

Basic software components for SQL Anywhere

Figure 2-5 shows the basic software components required to connect to a SQL Anywhere data source in InfoMaker.

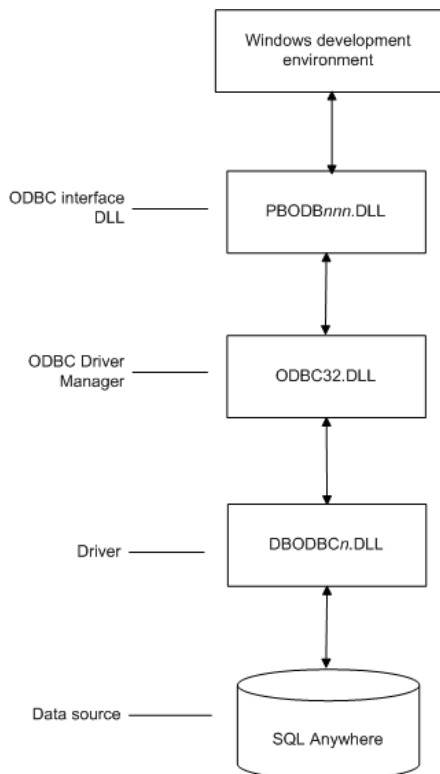
Figure 2-5: Components of a SQL Anywhere connection

Preparing to use the SQL Anywhere data source

Before you define and connect to a SQL Anywhere data source in InfoMaker, follow these steps to prepare the data source.

❖ **To prepare a SQL Anywhere data source:**

- 1 Make sure the database file for the SQL Anywhere data source already exists. You can create a new database by:
 - Launching the Create SQL Anywhere Database utility. You can access this utility from the Utilities folder for the ODBC interface in the Database profile or Database painter when InfoMaker is running on your computer.

This method creates a local SQL Anywhere database on your computer, and also creates the data source definition and database profile for this connection. (For instructions, see the *Users Guide*.)

- Creating the database some other way, such as with InfoMaker running on another user's computer or by using SQL Anywhere outside InfoMaker. (For instructions, see the SQL Anywhere documentation.)
- 2 Make sure you have the log file associated with the SQL Anywhere database so that you can fully recover the database if it becomes corrupted.

If the log file for the SQL Anywhere database does not exist, the SQL Anywhere database engine creates it. However, if you are copying or moving a database from another computer or directory, you should copy or move the log file with it.

Defining the SQL Anywhere data source

When you create a local SQL Anywhere database, InfoMaker automatically creates the data source definition and database profile for you. Therefore, you need only use the following procedure to define a SQL Anywhere data source when you want to access a SQL Anywhere database not created using InfoMaker on your computer.

- ❖ **To define a SQL Anywhere data source for the SQL Anywhere driver:**
 - 1 Select Create ODBC Data Source from the list of ODBC utilities in the Database Profiles dialog box or the Database painter.
 - 2 Select User Data Source and click Next.
 - 3 On the Create New Data Source page, select the SQL Anywhere driver and click Finish.

The ODBC Configuration for SQL Anywhere dialog box displays:

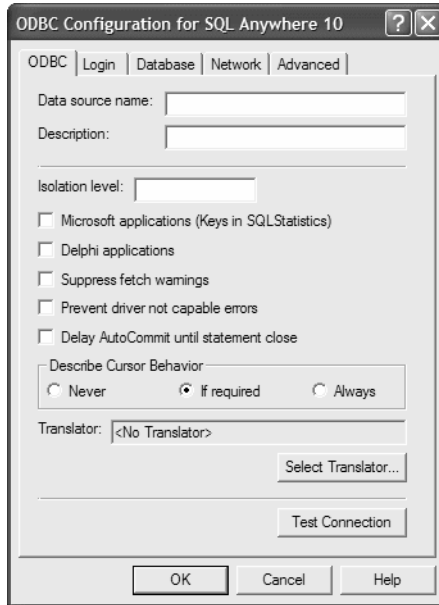

- 4 You must supply the following values:
 - Data source name on the ODBC tab page
 - User ID and password on the Login tab page
 - Database file on the Database tab page

Use the Help button to get information about fields in the dialog box.

- 5 (Optional) To select an ODBC translator to translate your data from one character set to another, click the Select button on the ODBC tab.

See “Selecting an ODBC translator” on page 26.

- 6 Click OK to save the data source definition.

Specifying a Start Line value

When the SQL Anywhere ODBC driver cannot find a running personal or network database server using the PATH variable and Database Name setting, it uses the commands specified in the Start Line field to start the database servers.

Specify one of the following commands in the Start Line field on the Database tab page, where *n* is the version of SQL Anywhere you are using.

Specify this command	To
dbeng <i>n</i> .exe	Start the personal database server and the database specified in the Database File box
rteng <i>n</i> .exe	Start the restricted runtime database server and the database specified in the Database File box

For information on completing the ODBC Configuration For SQL Anywhere dialog box, see the SQL Anywhere documentation.

Support for Transact-SQL special timestamp columns

When you work with a SQL Anywhere table in the Data Pipeline or Database painter, the default behavior is to treat any column named timestamp as a SQL Anywhere Transact-SQL® special timestamp column.

Creating special timestamp columns

You can create a Transact-SQL special timestamp column in a SQL Anywhere table.

- ❖ **To create a Transact-SQL special timestamp column in a SQL Anywhere table in InfoMaker:**
 - 1 Give the name timestamp to any column having a timestamp datatype that you want treated as a Transact-SQL special timestamp column. Do this in one of the following ways:
 - In the painter – Select timestamp as the column name. (For instructions, see the *Users Guide*.)
 - In a SQL CREATE TABLE statement – Follow the “CREATE TABLE example” next.
 - 2 Specify *timestamp* as the default value for the column. Do this in one of the following ways:
 - In the painter – Select timestamp as the default value for the column. (For instructions, see the *Users Guide*.)
 - In a SQL CREATE TABLE statement – Follow the “CREATE TABLE example” next.

- 3 If you are working with the table in the Data Pipeline painter, select the initial value exclude for the special timestamp column from the drop-down list in the Initial Value column of the workspace.

You must select exclude as the initial value to exclude the special timestamp column from INSERT or UPDATE statements.

For instructions, see the *Users Guide*.

CREATE TABLE example

The following CREATE TABLE statement defines a SQL Anywhere table named timesheet containing three columns: employee_ID (integer datatype), hours (decimal datatype), and timestamp (timestamp datatype and timestamp default value):

```
CREATE TABLE timesheet (  
    employee_ID INTEGER,  
    hours DECIMAL,  
    timestamp TIMESTAMP default timestamp )
```

Not using special timestamp columns

If you want to change the default behavior, you can specify that InfoMaker *not* treat SQL Anywhere columns named *timestamp* as Transact-SQL special timestamp columns.

❖ **To specify that InfoMaker *not* treat columns named *timestamp* as a Transact-SQL special timestamp column:**

- Edit the Sybase SQL Anywhere section of the PBODB115 initialization file to change the value of SQLSrvrTSName from 'Yes' to 'No'.

After making changes in the initialization file, you must reconnect to the database to have them take effect. See the Appendix, “Adding Functions to the PBODB115 Initialization File.”

What to do next

For instructions on connecting to the ODBC data source, see “Connecting to a database” on page 140.

Using the JDBC Interface

About this chapter

This chapter describes the JDBC interface and explains how to prepare to use this interface and how to define the JDBC database profile.

Contents

Topic	Page
About the JDBC interface	33
Preparing to use the JDBC interface	37
Defining the JDBC interface	39

For more information

For more detailed information about JDBC, go to the Java Web site at <http://java.sun.com/products/jdbc/overview.html>.

About the JDBC interface

You can access a wide variety of databases through JDBC in InfoMaker. This section describes what you need to know to use JDBC connections to access your data in InfoMaker.

What is JDBC?

The JDBC API

Java Database Connectivity (JDBC) is a standard application programming interface (API) that allows a Java application to access any database that supports Structured Query Language (SQL) as its standard data access language.

The JDBC API includes classes for common SQL database activities that allow you to open connections to databases, execute SQL commands, and process results. Consequently, Java programs have the capability to use the familiar SQL programming model of issuing SQL statements and processing the resulting data. The JDBC classes are included in Java 1.1+ and Java 2 as the `java.sql` package.

The JDBC API defines the following:

- A library of JDBC function calls that connect to a database, execute SQL statements, and retrieve results
- A standard way to connect and log in to a DBMS
- SQL syntax based on the X/Open SQL Call Level Interface or X/Open and SQL Access Group (SAG) CAE specification (1992)
- A standard representation for datatypes
- A standard set of error codes

How JDBC APIs are implemented

JDBC API implementations fall into two broad categories: those that communicate with an existing ODBC driver (a JDBC-ODBC bridge) and those that communicate with a native database API (a JDBC driver that converts JDBC calls into the communications protocol used by the specific database vendor). The InfoMaker implementation of the JDBC interface can be used to connect to any database for which a JDBC-compliant driver exists.

The InfoMaker JDB interface

A Java Virtual Machine (JVM) is required to interpret and execute the bytecode of a Java program. The InfoMaker JDB interface supports the Sun Java Runtime Environment (JRE) versions 1.2 and later.

Components of a JDBC connection

How a JDBC connection is made

In InfoMaker when you access a database through the JDBC interface, your connection goes through several layers before reaching the database. It is important to understand that each layer represents a separate component of the connection, and that each component might come from a different vendor.

Because JDBC is a standard API, InfoMaker uses the same interface to access every JDBC-compliant database driver.

Figure 3-1 shows the general components of a JDBC connection.

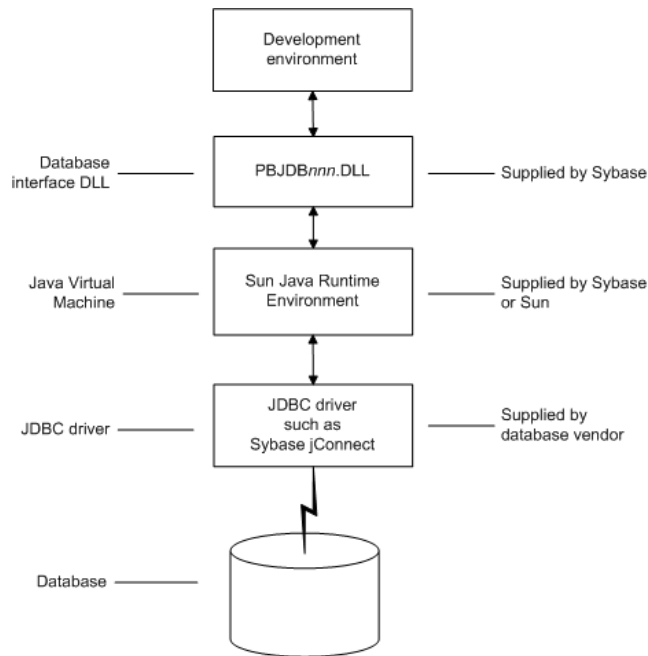
Figure 3-1: Components of a JDBC connection

The JDBC DLL

InfoMaker provides the *pbjdb115.dll*. This DLL runs with the Sun Java Runtime Environment (JRE) versions 1.1 and later.

InfoMaker Java package

InfoMaker includes a small package of Java classes that gives the JDBC interface the level of error-checking and efficiency (SQLException catching) found in other InfoMaker interfaces. The package is called *pbjdb12115.jar* and is found in *Sybase\Shared\PowerBuilder*.

The Java Virtual Machine

The Java Virtual Machine (JVM) is a component of Java development software. When you install InfoMaker, the Sun Java Development Kit (JDK), including the Java Runtime Environment (JRE), is installed on your system in *Sybase\Shared\PowerBuilder*. For InfoMaker 11.5, JDK 1.5 is installed. This version of the JVM is started when you use a JDBC connection or any other process that requires a JVM and is used throughout the InfoMaker session.

If you need to use a different JVM, see the instructions in “Preparing to use the JDBC interface” on page 37. For more information about how the JVM is started, see the chapter on deploying your application in the *Users Guide*.

The JDBC drivers	The JDBC interface can communicate with any JDBC-compliant driver including Sybase jConnect™ for JDBC and the Oracle and IBM Informix JDBC drivers. These drivers are native-protocol, all-Java drivers—that is, they convert JDBC calls into the SQL syntax supported by the databases.
Accessing Unicode data	<p>Using the ODBC interface, InfoMaker can connect, save, and retrieve data in both ANSI/DBCS and Unicode databases but does not convert data between Unicode and ANSI/DBCS. When character data or command text is sent to the database, InfoMaker sends a Unicode string. The driver must guarantee that the data is saved as Unicode data correctly. When InfoMaker retrieves character data, it assumes the data is Unicode.</p> <p>A Unicode database is a database whose character set is set to a Unicode format, such as UTF-8, UTF-16, UCS-2, or UCS-4. All data must be in Unicode format, and any data saved to the database must be converted to Unicode data implicitly or explicitly.</p> <p>A database that uses ANSI (or DBCS) as its character set might use special datatypes to store Unicode data. Columns with these datatypes can store <i>only</i> Unicode data. Any data saved into such a column must be converted to Unicode explicitly. This conversion must be handled by the database server or client.</p>

JDBC registry entries

When you access data through the InfoMaker JDBC interface, InfoMaker uses an internal registry to maintain definitions of SQL syntax, DBMS-specific function calls, and default DBParm parameter settings for the back-end DBMS. This internal registry currently includes subentries for SQL Anywhere, Adaptive Server Enterprise, and Oracle databases.

In most cases you do not need to modify the JDBC entries. However, if you do need to customize the existing entries or add new entries, you can make changes to the system registry by editing the registry directly or executing a registry file. Changes you introduce in the system registry override the InfoMaker internal registry entries. See the *egreg.txt* file in *Sybase\Shared\PowerBuilder* for an example of a registry file you could execute to change entry settings.

Supported versions for JDBC

The InfoMaker JDBC interface uses the *pbjdb115.dll* to access a database through a JDBC driver.

To use the JDBC interface to access the jConnect driver, use jConnect Version 4.2 or higher. For information on jConnect, see your Sybase documentation.

To use the JDBC interface to access the Oracle JDBC driver, use Oracle 8 JDBC driver Version 8.0.4 or higher. For information on the Oracle JDBC driver, see your Oracle documentation.

Supported JDBC datatypes

Like ODBC, the JDBC interface compiles, sorts, presents, and uses a list of datatypes that are native to the back-end database to emulate as much as possible the behavior of a native interface.

Preparing to use the JDBC interface

Before you define the interface and connect to a database through the JDBC interface, follow these steps to prepare the database for use:

- 1 Configure the database server for its JDBC connection and install its JDBC-compliant driver and network software.
- 2 Install the JDBC driver.
- 3 Set or verify the settings in the CLASSPATH environment variable.

Step 1: Configure the database server

You must configure the database server to make JDBC connections as well as install the JDBC driver and network software.

❖ **To configure the database server for its JDBC connection:**

- 1 Make sure the database server is configured to make JDBC connections. For configuration instructions, see your database vendor's documentation.
- 2 Make sure the appropriate JDBC driver software is installed and running on the database server.

The driver vendor's documentation should provide the driver name, URL format, and any driver-specific properties you need to specify in the database profile. For notes about the jConnect driver, see "Configuring the jConnect driver" on page 38.

- 3 Make sure the required network software (such as TCP/IP) is installed and running on your computer and is properly configured so that you can connect to the database server at your site.

You must install the network communication driver that supports the network protocol and operating system platform you are using.

For installation and configuration instructions, see your network or database administrator.

Step 2: Install the JDBC driver

In the InfoMaker Setup program, select the Typical install, or select the Custom install and select the JDBC driver.

Step 3: Verify or set the settings in the CLASSPATH variable and Java tab

Verify that the settings in the PATH and CLASSPATH environment variables point to the appropriate, fully qualified file names, or set them.

If you are using the JDK installed with InfoMaker, you do not need to make any changes to these environment variables.

If you are using JDK 1.2 or later, you do not need to include any Sun Java VM packages in your CLASSPATH variable, but your PATH environment variable must include an entry for the Sun Java VM library, *jvm.dll* (for example, *path\JDK15\JRE\bin\client*).

Configuring the jConnect driver

If you are using the Sybase jConnect driver, make sure to complete the required configuration steps such as installing the JDBC stored procedures in Adaptive Server databases. Also, verify that the CLASSPATH environment variable on your computer includes an entry pointing to the location of the jConnect driver.

For example, if you are using jConnect 6.05, you should include an entry similar to the following:

```
C:\Program Files\Sybase\jConnect-6.05\classes\jconn3.jar
```

For more information about configuring jConnect, see the jConnect for JDBC documentation.

Defining the JDBC interface

Defining the profile

To define a connection through the JDBC interface, you must create a database profile by supplying values for at least the basic connection parameters in the Database Profile Setup - JDBC dialog box. You can then select this profile at any time to connect to your database in the development environment.

For information on how to define a database profile, see “Using database profiles” on page 6.

Specifying connection parameters

To provide maximum flexibility (as provided in the JDBC API), the JDBC interface supports database connections made with different combinations of connection parameters:

- **Driver name, URL, and Properties** You should specify values for this combination of connection parameters if you need to define driver-specific properties. When properties are defined, you *must* also define the user ID and password in the properties field.

For example, when connecting to the jConnect driver, enter the following values in the Driver-Specific Properties field:

```
SQLINITSTRING=set TextSize 32000;
user=system;password=manager;
```

- **Driver name, URL, User ID, and Password** You should specify values for this combination of connection parameters if you do not need to define any driver-specific properties.

```
Driver Name: com.sybase.jdbc3.jdbc.SybDriver
URL: jdbc:sybase:Tds:localhost:2638
Login ID: dba
Password: sql
```

- **Driver name and URL** You should specify values for this combination of connection parameters when the user ID and password are included as part of the URL.

For example, when connecting to the Oracle JDBC driver, the URL can include the user ID and password:

```
jdbc:oracle:thin:userid/password@host:port:dbname
```

Specifying properties when connecting to jConnect

If you plan to use the blob datatype in InfoMaker, you should be aware that jConnect imposes a restriction on blob size. Consequently, before you make your database connection from InfoMaker, you might want to reset the blob size to a value greater than the maximum size you plan to use.

To set blob size, define the jConnect property `SQLINITSTRING` in the Driver-Specific Properties box on the Connection page. The `SQLINITSTRING` property is used to define commands to be passed to the back-end database server:

```
SQLINITSTRING=set TextSize 32000;
```

Remember that if you define a property in the Driver-Specific Properties box, you must also define the user ID and password in this box.

Using the OLE DB Interface

About this chapter

This chapter describes the OLE DB interface and explains how to prepare to use this interface and how to define the OLE DB database profile.

Contents

Topic	Page
About the OLE DB interface	41
Preparing to use the OLE DB interface	45
Defining the OLE DB interface	47

For more information

This chapter gives general information about using the OLE DB interface. For more detailed information:

- See the *OLE DB Programmer's Guide* in the Microsoft MSDN library at <http://msdn.microsoft.com/en-us/library/ms713643.aspx>.
- Use the online Help provided by the data provider vendor.
- Check to see if there is a technical document that describes how to connect to your OLE DB data provider. Any updated information about connectivity issues is available from Sybase Support and Downloads Web site at <http://www.sybase.com/support>.

About the OLE DB interface

You can access a wide variety of data through OLE DB data providers in InfoMaker. This section describes what you need to know to use OLE DB connections to access your data in InfoMaker.

Supported OLE DB data providers

For a complete list of the OLE DB data providers supplied with InfoMaker and the data they access, see "Supported Database Interfaces" in the online Help.

What is OLE DB?

OLE DB API

OLE DB is a standard application programming interface (API) developed by Microsoft. It is a component of Microsoft's Data Access Components software. OLE DB allows an application to access a variety of data for which OLE DB data providers exist. It provides an application with uniform access to data stored in diverse formats, such as indexed-sequential files like Btrieve, personal databases like Paradox, productivity tools such as spreadsheets and electronic mail, and SQL-based DBMSs.

The OLE DB interface supports direct connections to SQL-based databases.

Accessing data through OLE DB

Applications like InfoMaker that provide an OLE DB interface can access data for which an OLE DB data provider exists. An **OLE DB data provider** is a dynamic link library (DLL) that implements OLE DB function calls to access a particular data source.

The InfoMaker OLE DB interface can connect to any OLE DB data provider that supports the OLE DB object interfaces listed in Table 4-1. An OLE DB data provider must support these interfaces in order to adhere to the Microsoft OLE DB 2.0 specification.

Table 4-1: Required OLE DB interfaces

IAccessor	IDBInitialize
IColumnsInfo	IDBProperties
ICommand	IOpenRowset
ICommandProperties	IRowset
ICommandText	IRowsetInfo
IDBCreateCommand	IDBSchemaRowset
IDBCreateSession	ISourcesRowset

In addition to the required OLE DB interfaces, InfoMaker also uses the OLE DB interfaces listed in Table 4-2 to provide further functionality.

Table 4-2: Additional OLE DB interfaces

OLE DB interface	Use in InfoMaker
ICommandPrepare	Preparing commands and retrieving column information.
IDBInfo	Querying the data provider for its properties. If this interface is not supported, database connections might fail.
IDBCommandWithParameters	Querying the data provider for parameters.
IErrorInfo	Providing error information.
IErrorRecords	Providing error information.

OLE DB interface	Use in InfoMaker
IIndexDefinition	Creating indexes for the extended attribute system tables. Also creating indexes in the Database painter. If this interface is not supported, InfoMaker looks for index definition syntax in the <i>pbodb115.ini</i> file.
IMultipleResults	Providing information.
IRowsetChange	Populating the extended attribute system tables when they are created. Also, for updating blobs.
IRowsetUpdate	Creating the extended attribute system tables.
ISQLErrorInfo	Providing error information.
ISupportErrorInfo	Providing error information.
ITableDefinition	Creating the extended attribute system tables and also for creating tables in the Database painter. If this interface is not supported, the following behavior results: <ul style="list-style-type: none"> • InfoMaker looks for table definition syntax in the <i>pbodb115.ini</i> file • InfoMaker catalog tables cannot be used • DDL and DML operations, like modifying columns or editing data in the database painter, do not function properly
ITransactionLocal	Supporting transactions. If this interface is not supported, InfoMaker defaults to AutoCommit mode.

Accessing Unicode data

Using the OLE DB interface, InfoMaker can connect, save, and retrieve data in both ANSI/DBCS and Unicode databases but does not convert data between Unicode and ANSI/DBCS. When character data or command text is sent to the database, InfoMaker sends a Unicode string. The data provider must guarantee that the data is saved as Unicode data correctly. When InfoMaker retrieves character data, it assumes the data is Unicode.

A Unicode database is a database whose character set is set to a Unicode format, such as UTF-8, UTF-16, UCS-2, or UCS-4. All data must be in Unicode format, and any data saved to the database must be converted to Unicode data implicitly or explicitly.

A database that uses ANSI (or DBCS) as its character set might use special datatypes to store Unicode data. Columns with these datatypes can store *only* Unicode data. Any data saved into such a column must be converted to Unicode explicitly. This conversion must be handled by the database server or client.

Components of an OLE DB connection

When you access an OLE DB data provider in InfoMaker, your connection goes through several layers before reaching the data provider. It is important to understand that each layer represents a separate component of the connection, and that each component might come from a different vendor.

Because OLE DB is a standard API, InfoMaker uses the same interface to access every OLE DB data provider. As long as an OLE DB data provider supports the object interfaces required by InfoMaker, InfoMaker can access it through the OLE DB interface.

Figure 4-1 shows the general components of a OLE DB connection.

Figure 4-1: Components of an OLE DB connection

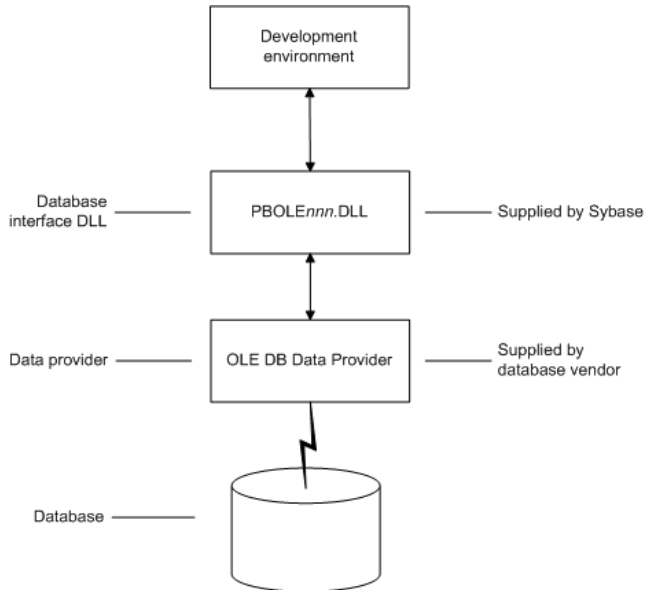

Obtaining OLE DB data providers

InfoMaker lets you access data with *any* OLE DB data provider obtained from a vendor other than Sybase if that data provider supports the OLE DB object interfaces required by InfoMaker. In most cases, these drivers work with InfoMaker. However, Sybase might not have tested the drivers to verify this.

Supported versions for OLE DB

The OLE DB interface uses a DLL named *PBOLE115.DLL* to access a database through an OLE DB data provider.

Required OLE DB version

To use the OLE DB interface to access an OLE DB database, you must connect through an OLE DB data provider that supports OLE DB version 2.0 or later. For information on OLE DB specifications, see the Microsoft documentation at <http://msdn.microsoft.com/en-us/library/default.aspx>.

Preparing to use the OLE DB interface

Before you define the interface and connect to a data provider through OLE DB:

- 1 Install and configure the database server, network, and client software.
- 2 Install the OLE DB interface and the OLE DB data provider that accesses your data source.
- 3 Install Microsoft's Data Access Components software on your machine.
- 4 If required, define the OLE DB data source.

Step 1: Install and configure the data server

You must install and configure the database server and install the network software and client software.

❖ **To install and configure the database server, network, and client software:**

- 1 Make sure the appropriate database software is installed and running on its server.

You must obtain the database server software from your database vendor. For installation instructions, see your database vendor's documentation.

- 2 Make sure the required network software (such as TCP/IP) is installed and running on your computer and is properly configured so that you can connect to the data server at your site. You must install the network communication driver that supports the network protocol and operating system platform you are using.

For installation and configuration instructions, see your network or data source administrator.

- 3 If required, install the appropriate client software on each client computer on which InfoMaker is installed.

Client software requirements

To determine client software requirements, see your database vendor's documentation.

Step 2: Install the OLE DB interface and data provider

In the InfoMaker Setup program, select the Custom install and select the OLE DB provider that accesses your database. You can install one or more of the OLE DB data providers shipped with InfoMaker, or you can install data providers from another vendor later.

Step 3: Install the Microsoft Data Access Components software

The InfoMaker OLE DB interface requires the functionality of the Microsoft Data Access Components (MDAC) version 2.8 or higher software. Version 2.8 is distributed with Windows XP Service Pack 2 and Windows Server 2003.

To check the version of MDAC on your computer, you can download and run the MDAC Component Checker utility from the MDAC Downloads page at <http://msdn.microsoft.com/en-us/data/aa937730.aspx>.

On the Windows Vista operating system, Windows Data Access Components (DAC) 6.0 includes some changes to work with Vista but is otherwise functionally equivalent to MDAC 2.8.

OLE DB data providers installed with MDAC

Several Microsoft OLE DB data providers are automatically installed with MDAC, including the providers for SQL Server (SQLOLEDB) and ODBC (MSDASQL).

Step 4: Define the OLE DB data source

Once the OLE DB data provider is installed, you might have to define the OLE DB data source the data provider will access. How you define the data source depends on the OLE DB data provider you are using and the vendor who provided it.

If you are connecting to an ODBC data provider (such as Microsoft's OLE DB Provider for ODBC), you must define the ODBC data source as you would if you were using a direct ODBC connection. To define an ODBC data source, use Microsoft's ODBC Data Source Administrator. You can access this utility from the Control Panel in Windows or from the Database painter or Database Profile Setup dialog box in InfoMaker.

Defining the OLE DB interface

Using the OLE DB Database Profile Setup

To define a connection through the OLE DB interface, you must create a database profile by supplying values for at least the basic connection parameters in the Database Profile Setup – OLE DB dialog box. You can then select this profile anytime to connect to your data in the development environment.

For information on how to define a database profile, see “Using database profiles” on page 6.

Specifying connection parameters

You must supply values for the Provider and Data Source connection parameters. Select a data provider from the list of installed data providers in the Provider drop-down list. The Data Source value varies depending on the type of data source connection you are making. For example:

- If you are using Microsoft’s OLE DB Provider for ODBC to connect to the EAS Demo DB, you select MSDASQL as the Provider value and enter the actual ODBC data source name (for example, EAS Demo DB) as the Data Source value.
- If you are using Microsoft’s OLE DB Provider for SQL Server, you select SQLOLEDB as the Provider value and enter the actual server name as the Data Source value. You must also use the Extended Properties field to provide the database name (for example, Database=Pubs) since you can have multiple instances of a database.

Using the Data Link API

The Data Link option allows you to access Microsoft’s Data Link API, which allows you to define a file or use an existing file that contains your OLE DB connection information. A Data Link file is identified with the suffix *.udl*. If you use a Data Link file to connect to your data source, all other settings you make in the OLE DB Database Profile Setup dialog box are ignored.

To launch this option, select the File Name check box on the Connection tab and double-click on the button next to the File Name box. (You can also launch the Data Link API in the Database painter by double-clicking on the Manage Data Links utility included with the OLE DB interface in the list of Installed Database Interfaces.)

For more information on using the Data Link API, see the *OLE DB Programmer’s Guide* in the Microsoft MSDN library at <http://msdn.microsoft.com/en-us/library/ms713643.aspx>.

PART 3

Working with Native Database Interfaces

This part describes how to set up and define database connections accessed through one of the native database interfaces.

About this chapter

This chapter describes native database interfaces. The following chapters explain how to prepare to use the database and define any unique database interface parameters so that you can access your data.

Contents

Topic	Page
About native database interfaces	51
Components of a database interface connection	52
Using a native database interface	53

About native database interfaces

The native database interfaces provide native connections to many databases and DBMSs. This chapter describes how the native database interfaces access these databases.

For a complete list of the supported native database interfaces, see “Supported Database Interfaces” in online Help.

A native database interface is a direct connection to your data in InfoMaker.

Each native database interface uses its own interface DLL to communicate with a specified database through a vendor-specific database API. For example, the SQL Native Client interface for Microsoft SQL Server uses a DLL named *PBSNC115.DLL* to access the database, whereas the Oracle 11g database interface accesses the database through *PBORA115.DLL*.

In contrast, a standard database interface uses a standard API to communicate with the database. For example, InfoMaker can use a single-interface DLL (*PBODB115.DLL*) to communicate with the ODBC Driver Manager and corresponding driver to access any ODBC data source.

Components of a database interface connection

When you use a native database interface to access a database, your connection goes through several layers before reaching the data. Each layer is a separate component of the connection and each component might come from a different vendor.

Figure 5-1: Components of a database connection

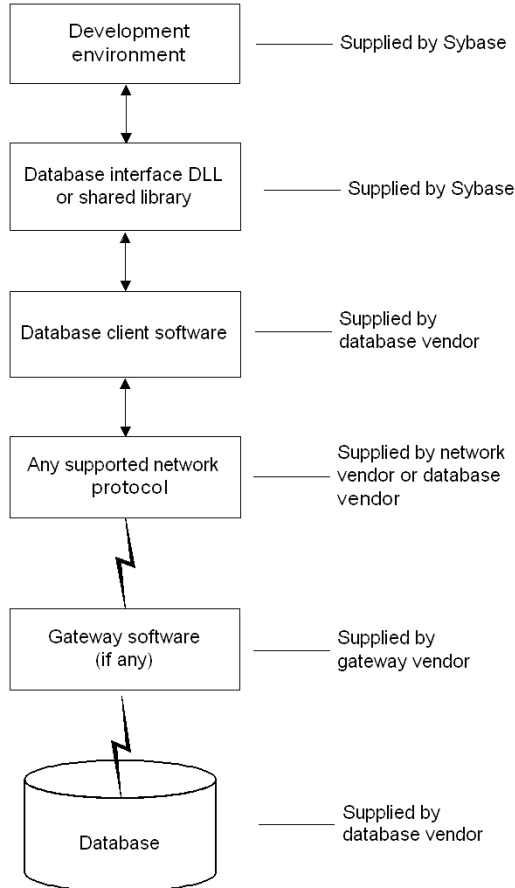

For diagrams showing the specific components of your connection, see “Basic software components” in the chapter for your native database interface.

Using a native database interface

You perform several basic steps to use a native database interface to access a database.

About preparing to use the database

The first step in connecting to a database through a native database interface is to prepare to use the database. Preparing the database ensures that you will be able to access and use your data in InfoMaker.

You must prepare the database *outside* InfoMaker *before* you start the product, then define the database interface and connect to it. The requirements differ for each database—but in general, preparing a database involves four basic steps.

❖ **To prepare to use your database with InfoMaker:**

- 1 Make sure the required database server software is properly installed and configured at your site.
- 2 If network software is required, make sure it is properly installed and configured at your site and on the client computer so that you can connect to the database server.
- 3 Make sure the required database client software is properly installed and configured on the client computer. (Typically, the client computer is the one running InfoMaker.)

You must obtain the client software from your database vendor and make sure that the version you install supports *all* of the following:

- The operating system running on the client computer
- The version of the database that you want to access
- The version of InfoMaker that you are running

- 4 Verify that you can connect to the server and database you want to access outside InfoMaker.

For specific instructions to use with your database, see “Preparing to use the database” in the chapter for your native database interface.

About installing native database interfaces

After you prepare to use the database, you must install the native database interface that accesses the database. See the instructions for each interface for more information.

About defining native database interfaces

Once you are ready to access the database, you start InfoMaker and define the database interface. To define a database interface, you must create a database profile by completing the Database Profile Setup dialog box for that interface.

For general instructions, see “About creating database profiles” on page 6. For instructions about defining database interface parameters unique to a particular database, see “Preparing to use the database” in the chapter for your database interface.

For more information

The following chapters give general information about using each native database interface. For more detailed information:

- Check to see if there is a technical document that describes how to connect to your database. Any updated information about connectivity issues is available from the Sybase Support and Downloads Web site at <http://www.sybase.com/support>.
- Ask your network or system administrator for assistance when installing and setting up the database server and client software at your site.

About this chapter

This section describes how to use the Adaptive Server Enterprise database interfaces in InfoMaker.

Contents

Topic	Page
Supported versions for Adaptive Server	55
Supported Adaptive Server datatypes	56
Basic software components for Adaptive Server	58
Preparing to use the Adaptive Server database	59
Defining the Adaptive Server database interface	61
Using Open Client security services	62
Using Open Client directory services	64
Using PRINT statements in Adaptive Server stored procedures	67
Creating a report based on a cross-database join	67
Installing stored procedures in Adaptive Server databases	68

Supported versions for Adaptive Server

You can access Adaptive Server versions 11.x, 12.x, and 15.x using the SYC Adaptive Server database interface. Use of this interface to access other Open Server™ programs is not supported. The SYC database interface uses a DLL named *PBSYC115.DLL* to access the database through the Open Client™ CT-Lib API.

You can also access Adaptive Server version 15.x using the ASE Adaptive Server database interface. Use of this interface to access other Open Server programs is not supported. The Adaptive Server database interface uses a DLL named *PBASE115.DLL* to access the database through the Open Client CT-Lib API. To use this interface, the Adaptive Server 15 client must be installed on the client computer. The ASE interface supports large identifiers with up to 128 characters.

Client Library API

The Adaptive Server database interfaces use the Open Client CT-Library (CT-Lib) application programming interface (API) to access the database.

When you connect to an Adaptive Server database, InfoMaker makes the required calls to the API. Therefore, you do not need to know anything about CT-Lib to use the database interface.

Supported Adaptive Server datatypes

The Adaptive Server interface supports the Sybase datatypes listed in Table 6-1 in reports.

Table 6-1: Supported datatypes for Adaptive Server Enterprise

Binary	NVarChar
BigInt (15.x and later)	Real
Bit	SmallDateTime
Char (see “Column-length limits” on page 57)	SmallInt
DateTime	SmallMoney
Decimal	Text
Double precision	Timestamp
Float	TinyInt
Identity	UniChar
Image	UniText (15.x and later)
Int	UniVarChar
Money	VarBinary
NChar	VarChar
Numeric	

In Adaptive Server 15.0 and later, InfoMaker supports unsigned as well as signed bigint, int, and smallint datatypes. You can also use the following datatypes as identity columns in Adaptive Server 15.0 and later: bigint, int, numeric, smallint, tinyint, unsigned bigint, unsigned int, and unsigned smallint.

Accessing Unicode data

InfoMaker can connect, save, and retrieve data in both ANSI/DBCS and Unicode databases. When character data or command text is sent to the database, InfoMaker sends a DBCS string if the UTF8 database parameter is set to 0 (the default). If UTF8 is set to 1, InfoMaker sends a UTF-8 string. The database server must be configured correctly to accept UTF-8 strings. See the description of the UTF8 database parameter in the online Help for more information.

The character set used by an Adaptive Server database server applies to all databases on that server. The `nchar` and `nvarchar` datatypes can store UTF-8 data if the server character set is UTF-8. The Unicode datatypes `unichar` and `univarchar` were introduced in Adaptive Server 12.5 to support Unicode data. Columns with these datatypes can store *only* Unicode data. Any data saved into such a column must be converted to Unicode explicitly. This conversion must be handled by the database server or client.

In Adaptive Server 12.5.1 and later, additional support for Unicode data has been added. For more information, see the documentation for your version of Adaptive Server.

Different display values in painters

The `unichar` and `univarchar` datatypes support UTF-16 encoding, therefore each `unichar` or `univarchar` character requires two bytes of storage. The following example creates a table with one `unichar` column holding 10 Unicode characters:

```
create table unitbl (unicol unichar(10))
```

In the Database painter, the column displays as `unichar(20)` because the column requires 20 bytes of storage. This is consistent with the way the column displays in Sybase Central.

However, the mapping between the Type in the Column Specifications view in the Report painter and the column datatype of a table in the database is not one-to-one. The Type in the Column Specifications view shows the DataWindow® column datatype and DataWindow column length. The column length is the number of characters, therefore an Adaptive Server `unichar(20)` column displays as `char(10)` in the Column Specifications view.

Column-length limits

Adaptive Server 12.0 and earlier have a column-length limit of 255 bytes. Adaptive Server 12.5.x and later support wider columns for `Char`, `VarChar`, `Binary`, and `VarBinary` datatypes, depending on the logical page size and the locking scheme used by the server.

In InfoMaker, you can use these wider columns for `Char` and `VarChar` datatypes with Adaptive Server 12.5.x when the following conditions apply:

- The Release database parameter is set to 12.5 or higher.

- You are accessing the database using Open Client 12.5.x or later.

The database must be configured to use a larger page size to take full advantage of the widest limits.

For detailed information about wide columns and configuration issues, see the Adaptive Server documentation on the Product Manuals Web site at <http://www.sybase.com/support/manuals/>. For more information about the Release database parameter, see the online Help.

Basic software components for Adaptive Server

You must install the software components in Figure 6-1 to access an Adaptive Server database in InfoMaker.

Figure 6-1: Components of an Adaptive Server Enterprise connection

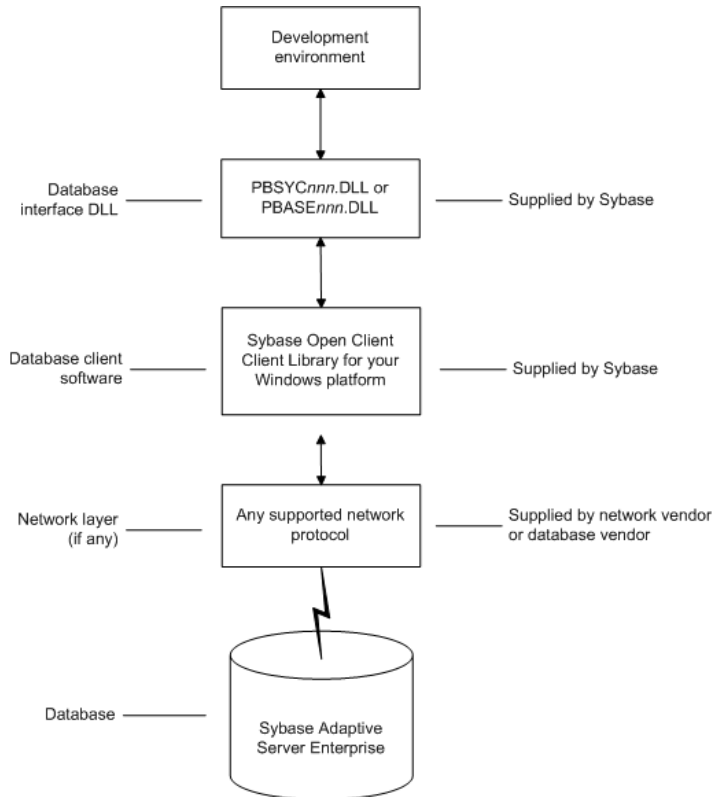

Preparing to use the Adaptive Server database

Before you define the interface and connect to an Adaptive Server database in InfoMaker, follow these steps to prepare the database for use:

- 1 Install and configure the required database server, network, and client software.
- 2 Install the Adaptive Server database interface.
- 3 Verify that you can connect to Adaptive Server outside InfoMaker.
- 4 Install the required InfoMaker stored procedures in the sybsystemprocs database.

Preparing an Adaptive Server database for use with InfoMaker involves these four basic tasks.

Step 1: Install and configure the database server

You must install and configure the database server, network, and client software for Adaptive Server.

❖ **To install and configure the database server, network, and client software:**

- 1 Make sure the Adaptive Server database software is installed on the server specified in your database profile.

You must obtain the database server software from Sybase.

For installation instructions, see your Adaptive Server documentation.

- 2 Make sure the supported network software (for example, TCP/IP) is installed and running on your computer and is properly configured so that you can connect to the database server at your site.

You must install the network communication driver that supports the network protocol and operating system platform you are using. The driver is installed as part of the Net-Library client software.

For installation and configuration instructions, see your network or database administrator.

- 3 Install the required Open Client CT-Library (CT-Lib) software on each client computer on which InfoMaker is installed.

You must obtain the Open Client software from Sybase. Make sure the version of Open Client you install supports *all* of the following:

- The operating system running on the client computer
- The version of Adaptive Server that you want to access
- The version of InfoMaker that you are running

Required client software versions

To use the ASE Adaptive Server interface, you must install Open Client version 15.x or later. To use the SYC Adaptive Server interface, you must install Open Client version 11.x or later.

- 4 Make sure the Open Client software is properly configured so that you can connect to the database at your site.

Installing the Open Client software places the *SQL.INI* configuration file in the Adaptive Server directory on your computer.

SQL.INI provides information that Adaptive Server needs to find and connect to the database server at your site. You can enter and modify information in *SQL.INI* by using the configuration utility that comes with the Open Client software.

For information about setting up the *SQL.INI* or other required configuration file, see your Adaptive Server documentation.

- 5 If required by your operating system, make sure the directory containing the Open Client software is in your system path.
- 6 Make sure only one copy of each of the following files is installed on your client computer:

- Adaptive Server interface DLL
- Network communication DLL (for example, *NLWNSCK.DLL* for Windows Sockets-compliant TCP/IP)
- Database vendor DLL (for example, *LIBCT.DLL*)

Step 2: Install the database interface

In the InfoMaker Setup program, select the Typical install, or select the Custom install and select the Adaptive Server Enterprise (ASE or SYC) database interface.

Step 3: Verify the connection

Make sure you can connect to the Adaptive Server database server and log in to the database you want to access from outside InfoMaker.

Some possible ways to verify the connection are by running the following tools:

- **Accessing the database server** Tools such as the Open Client/Open Server Configuration utility (or any Ping utility) check whether you can reach the database server from your computer.
- **Accessing the database** Tools such as ISQL (interactive SQL utility) check whether you can log in to the database and perform database operations. It is a good idea to specify the same connection parameters you plan to use in your InfoMaker database profile to access the database.

Step 4: Install the InfoMaker stored procedures

InfoMaker requires you to install certain stored procedures in the sybssystemprocs database *before* you connect to an Adaptive Server database for the first time. InfoMaker uses these stored procedures to get information about tables and columns from the DBMS system catalog.

Run the SQL script or scripts required to install the InfoMaker stored procedures in the sybssystemprocs database.

For instructions, see “Installing stored procedures in Adaptive Server databases” on page 68.

Defining the Adaptive Server database interface

To define a connection through the Adaptive Server interface, you must create a database profile by supplying values for at least the basic connection parameters in the Database Profile Setup - Adaptive Server Enterprise dialog box. You can then select this profile anytime to connect to your database in the development environment.

For information on how to define a database profile, see “Using database profiles” on page 6.

Using Open Client security services

The Adaptive Server interface provides several DBParm parameters that support Open Client 11.1.x or later network-based security services in your application. If you are using the required database, security, and InfoMaker software, you can build applications that take advantage of Open Client security services.

What are Open Client security services?

Open Client 11.1.x or later **security services** allow you to use a supported third-party security mechanism (such as CyberSafe Kerberos) to provide login authentication and per-packet security for your application. Login authentication establishes a secure connection, and per-packet security protects the data you transmit across the network.

Requirements for using Open Client security services

For you to use Open Client security services in your application, *all of the following must be true*:

- You are accessing an Adaptive Server database server using Open Client Client-Library (CT-Lib) 11.1.x or later software.
- You have the required network security mechanism and driver.

You have the required Sybase-supported network security mechanism and Sybase-supplied security driver properly installed and configured for your environment. Depending on your operating system platform, examples of supported security mechanisms include: Distributed Computing Environment (DCE) security servers and clients, CyberSafe Kerberos, and Windows NT LAN Manager Security Services Provider Interface (SSPI).

For information about the third-party security mechanisms and operating system platforms that Sybase has tested with Open Client security services, see the Open Client documentation.

- You can access the secure server outside InfoMaker.

You must be able to access a secure Adaptive Server server using Open Client 11.1.x or later software from outside InfoMaker.

To verify the connection, use a tool such as ISQL or SQL Advantage to make sure you can connect to the server and log in to the database with the same connection parameters and security options you plan to use in your InfoMaker application.

- You are using a database interface.

You are using the ASE or SYC Adaptive Server interface to access the database.

- The Release DBParm parameter is set to the appropriate value for your database.

You have set the Release DBParm parameter to 11 or higher to specify that your application should use the appropriate version of the Open Client CT-Lib software.

For instructions, see Release in the online Help.

- Your security mechanism and driver support the requested service.

The security mechanism and driver you are using must support the service requested by the DBParm parameter.

Security services DBParm parameters

If you have met the requirements described in “Requirements for using Open Client security services” on page 62, you can set the security services DBParm parameters in the Database Profile Setup dialog box for your connection.

There are two types of DBParm parameters that you can set to support Open Client security services: login authentication and per-packet security.

Login authentication DBParms

The following login authentication DBParm parameters correspond to Open Client 11.1.x or later connection properties that allow an application to establish a secure connection.

Sec_Channel_Bind
 Sec_Cred_Timeout
 Sec_Delegation
 Sec_Keytab_File
 Sec_Mechanism
 Sec_Mutual_Auth
 Sec_Network_Auth
 Sec_Server_Principal
 Sec_Sess_Timeout

For instructions on setting these DBParm parameters, see their descriptions in the online Help.

Per-packet security
DBParms

The following per-packet security DBParm parameters correspond to Open Client 11.1.x or later connection properties that protect each packet of data transmitted across a network. Using per-packet security services might create extra overhead for communications between the client and server.

Sec_Confidential
Sec_Data_Integrity
Sec_Data_Origin
Sec_Replay_Detection
Sec_Seq_Detection

For instructions on setting these DBParm parameters, see their descriptions in the online Help.

Using Open Client directory services

The Adaptive Server interface provides several DBParm parameters that support Open Client 11.1.x or later network-based directory services in your application. If you are using the required database, directory services, and InfoMaker software, you can build applications that take advantage of Open Client directory services.

What are Open Client directory services?

Open Client 11.1.x or later **directory services** allow you to use a supported third-party directory services product (such as the Windows Registry) as your directory service provider. Directory services provide centralized control and administration of the network entities (such as users, servers, and printers) in your environment.

Requirements for using Open Client directory services

For you to use Open Client directory services in your application, *all of the following must be true*:

- You are accessing an Adaptive Server database server using Open Client Client-Library (CT-Lib) 11.x or later software
- You have the required Sybase-supported directory service provider software and Sybase-supplied directory driver properly installed and configured for your environment. Depending on your operating system platform, examples of supported security mechanisms include the Windows Registry and Distributed Computing Environment Cell Directory Services (DCE/CDS).

For information about the directory service providers and operating system platforms that Sybase has tested with Open Client directory services, see the Open Client documentation.

- You must be able to access a secure Adaptive Server server using Open Client 11.1.x or later software from outside InfoMaker.

To verify the connection, use a tool such as ISQL or SQL Advantage to make sure you can connect to the server and log in to the database with the same connection parameters and directory service options you plan to use in your InfoMaker application.

- You are using the ASE or SYC Adaptive Server interface to access the database.
- You must use the correct syntax as required by your directory service provider when specifying the server name in a database profile. Different providers require different syntax based on their format for specifying directory entry names.

For information and examples for different directory service providers, see “Specifying the server name with Open Client directory services” next.

- You have set the Release DBParm to 11 or higher to specify that your application should use the behavior of the appropriate version of the Open Client CT-Lib software.

For instructions, see Release database parameter in the online Help.

- The directory service provider and driver you are using must support the service requested by the DBParm.

Specifying the server name with Open Client directory services

When you are using Open Client directory services in an InfoMaker application, you must use the syntax required by your directory service provider when specifying the server name in a database profile to access the database.

Different directory service providers require different syntax based on the format they use for specifying directory entry names. Directory entry names can be fully qualified or relative to the default (active) Directory Information Tree base (DIT base) specified in the Open Client/Server™ configuration utility.

The **DIT base** is the starting node for directory searches. Specifying a DITbase is analogous to setting a current working directory for UNIX or MS-DOS file systems. (You can specify a nondefault DIT base with the DS_DitBase DBParm. For information, see DS_DitBase in the online Help.)

Windows registry
server name example

This example shows typical server name syntax if your directory service provider is the Windows registry.

```
Node name: SALES:software\sybase\server\SYS12
DIT base: SALES:software\sybase\server
Server name: SYS12
```

❖ **To specify the server name in a database profile:**

- Type the following in the Server box on the Connection tab in the Database Profile Setup dialog box. Do *not* start the server name with a backslash (\).

```
SYS12
```

DCE/CDS server
name example

This example shows typical server name syntax if your directory service provider is Distributed Computing Environment Cell Directory Services (DCE/CDS).

```
Node name: /.../boston.sales/dataservers/sybase/SYS12
DIT base: /../boston.sales/dataservers
Server name: sybase/SYS12
```

❖ **To specify the server name in a database profile:**

- Type the following in the Server box on the Connection tab in the Database Profile Setup dialog box. Do *not* start the server name with a slash (/).

```
sybase/SYS12
```

Directory services DBParm parameters

If you have met the requirements described in “Requirements for using Open Client directory services” on page 65, you can set the directory services DBParms in a database profile for your connection.

The following DBParms correspond to Open Client 11.1.x or later directory services connection parameters:

- DS_Alias
- DS_Copy
- DS_DitBase
- DS_Failover
- DS_Password (Open Client 12.5 or later)
- DS_Principal
- DS_Provider
- DS_TimeLimit

For instructions on setting these DBParms, see their descriptions in the online Help.

Using PRINT statements in Adaptive Server stored procedures

The ASE or SYC Adaptive Server database interface allows you to use PRINT statements in your stored procedures for debugging purposes.

This means, for example, that if you turn on Database Trace when accessing the database through the ASE or SYC interface, PRINT messages appear in the trace log but they do not return errors or cancel the rest of the stored procedure.

Creating a report based on a cross-database join

The ability to create a report based on a heterogeneous cross-database join is available through the use of Adaptive Server’s Component Integration Services. Component Integration Services allow you to connect to multiple remote heterogeneous database servers and define multiple proxy tables that reference the tables residing on those servers.

For information on how to create proxy tables, see the Adaptive Server documentation.

Installing stored procedures in Adaptive Server databases

This section describes how to install InfoMaker stored procedures in an Adaptive Server Enterprise database by running SQL scripts provided for this purpose.

Sybase recommends that you run these scripts outside InfoMaker *before* connecting to an Adaptive Server database for the first time through the Adaptive Server (ASE or SYC DBMS identifier) native database interface. Although the database interface will work without the InfoMaker stored procedures created by these scripts, the stored procedures are required for full functionality.

What are the InfoMaker stored procedure scripts?

What you do

In order to work with an Adaptive Server database in InfoMaker, you or your system administrator should install certain stored procedures in the database *before* you connect to Adaptive Server from InfoMaker *for the first time*.

You must run the InfoMaker stored procedure scripts only once per database server, and not before each InfoMaker session. If you have already installed the InfoMaker stored procedures in your Adaptive Server database before connecting in InfoMaker on any supported platform, you need *not* install the stored procedures again before connecting in InfoMaker on a different platform.

InfoMaker stored procedures

A **stored procedure** is a group of precompiled and preoptimized SQL statements that performs some database operation. Stored procedures reside on the database server where they can be accessed as needed.

InfoMaker uses these stored procedures to get information about tables and columns from the Adaptive Server system catalog. (The InfoMaker stored procedures are different from the stored procedures you might create in your database.)

SQL scripts

InfoMaker provides SQL script files for installing the required stored procedures in the sybsystemprocs database:

Script	Use for
<i>PBSYC.SQL</i>	Adaptive Server databases
<i>PBSYC2.SQL</i>	Adaptive Server databases to restrict the Select Tables list

Where to find the scripts The stored procedure scripts are located in the *Server* directory on the InfoMaker CD-ROM. The *Server* directory contains server-side installation components that are *not* installed with InfoMaker on your computer.

PBSYC.SQL script

What it does The *PBSYC.SQL* script contains SQL code that overwrites stored procedures that correspond to the same version of InfoMaker in the Adaptive Server sybssystemprocs database and then re-creates them.

The *PBSYC.SQL* script uses the sybssystemprocs database to hold the InfoMaker stored procedures. This database is created when you install Adaptive Server.

When to run it Before you connect to an Adaptive Server database in InfoMaker *for the first time* using the ASE or SYC DBMS identifier, you or your database administrator *must run* the *PBSYC.SQL* script once per database server into the sybssystemprocs database.

Run *PBSYC.SQL* if the server at your site will be accessed by anyone using the InfoMaker or by deployment machines.

If you or your database administrator have already run the current version of *PBSYC.SQL* to install InfoMaker stored procedures in the sybssystemprocs database on your server, you need not rerun the script to install the stored procedures again.

For instructions on running *PBSYC.SQL*, see “How to run the scripts” on page 71.

Stored procedures it creates The *PBSYC.SQL* script creates the following InfoMaker stored procedures in the Adaptive Server sybssystemprocs database. The procedures are listed in the order in which the script creates them.

PBSYC.SQL stored procedure	What it does
sp_pb115column	Lists the columns in a table.
sp_pb115pkcheck	Determines whether a table has a primary key.
sp_pb115fktable	Lists the tables that reference the current table.
sp_pb115procdesc	Retrieves a description of the argument list for a specified stored procedure.

PBSYC.SQL stored procedure	What it does
sp_pb115proclist	<p>Lists available stored procedures and extended stored procedures.</p> <p>If the SystemProcs DBParm parameter is set to 1 or Yes (the default), sp_pb115proclist displays both system stored procedures and user-defined stored procedures. If SystemProcs is set to 0 or No, sp_pb115proclist displays only user-defined stored procedures.</p>
sp_pb115text	<p>Retrieves the text of a stored procedure from the SYSCOMMENTS table.</p>
sp_pb115table	<p>Retrieves information about <i>all</i> tables in a database, including those for which the current user has no permissions.</p> <p>PBSYC.SQL contains the default version of sp_pb115table. If you want to replace the default version of sp_pb115table with a version that restricts the table list to those tables for which the user has SELECT permission, you can run the <i>PBSYC2.SQL</i> script, described in “PBSYC2.SQL script” next.</p>
sp_pb115index	<p>Retrieves information about all indexes for a specified table.</p>

PBSYC2.SQL script

What it does

The *PBSYC2.SQL* script contains SQL code that drops and re-creates one InfoMaker stored procedure in the Adaptive Server subsystemprocs database: a replacement version of sp_pb115table.

The default version of sp_pb115table is installed by the *PBSYC.SQL* script. InfoMaker uses the sp_pb115table procedure to build a list of *all* tables in the database, including those for which the current user has no permissions. This list displays in the Select Tables dialog box in InfoMaker.

For security reasons, you or your database administrator might want to restrict the table list to display only those tables for which a user has permissions. To do this, you can run the *PBSYC2.SQL* script *after you run PBSYC.SQL*. *PBSYC2.SQL* replaces the default version of sp_pb115table with a new version that displays a restricted table list including only tables and views:

- Owned by the current user
- For which the current user has SELECT authority
- For which the current user’s group has SELECT authority
- For which SELECT authority was granted to PUBLIC

When to run it	<p>If you are accessing an Adaptive Server database using the ASE or SYC DBMS identifier in InfoMaker, <i>you must first run <code>PBSYC.SQL</code> once per database server to install the required InfoMaker stored procedures in the sybssystemprocs database.</i></p> <p>After you run <code>PBSYC.SQL</code>, you can optionally run <code>PBSYC2.SQL</code> if you want to replace <code>sp_pb115table</code> with a version that restricts the table list to those tables for which the user has SELECT permission.</p> <p>If you do not want to restrict the table list, there is no need to run <code>PBSYC2.SQL</code>.</p> <p>For instructions on running <code>PBSYC2.SQL</code>, see “How to run the scripts” on page 71.</p>
Stored procedure it creates	<p>The <code>PBSYC2.SQL</code> script creates the following InfoMaker stored procedure in the Adaptive Server sybssystemprocs database:</p>

PBSYC2.SQL stored procedure	What it does
<code>sp_pb115table</code>	<p>Retrieves information about those tables in the database for which the current user has SELECT permission.</p> <p>This version of <code>sp_pb115table</code> replaces the default version of <code>sp_pb115table</code> installed by the <code>PBSYC.SQL</code> script.</p>

How to run the scripts

You can use the ISQL or SQL Advantage tools to run the stored procedure scripts outside InfoMaker.

Using ISQL to run the stored procedure scripts

ISQL is an interactive SQL utility that comes with the Open Client software on the Windows platforms. If you have ISQL installed, use the following procedure to run the InfoMaker stored procedure scripts.

For complete instructions on using ISQL, see your Open Client documentation.

❖ **To use ISQL to run the InfoMaker stored procedure scripts:**

- 1 Connect to the sybsystemprocs Adaptive Server database as the system administrator.
- 2 Open one of the following files containing the InfoMaker stored procedure script you want to run:

PBSYC.SQL
PBSYC2.SQL

- 3 Issue the appropriate ISQL command to run the SQL script with the user ID, server name, and (optionally) password you specify. Make sure you specify uppercase and lowercase exactly as shown:

isql /U sa /S SERVERNAME /i pathname /P { password }

Parameter	Description
sa	The user ID for the system administrator. Do <i>not</i> change this user ID.
SERVERNAME	The name of the computer running the Adaptive Server database.
pathname	The drive and directory containing the SQL script you want to run.
password	(Optional) The password for the sa (system administrator) user ID. The default Adaptive Server installation creates the sa user ID without a password. If you changed the password for sa during the installation, replace <i>password</i> with your new password.

For example, if you are using InfoMaker and are accessing the stored procedure scripts from the product CD-ROM, type either of the following (assuming D is your CD-ROM drive):

```
isql /U sa /S TESTDB /i d:\server\pbsyb.sql /P
isql /U sa /S SALES /i d:\server\pbsyc.sql /P
adminpwd
```

Using SQL Advantage to run the stored procedure scripts

SQL Advantage is an interactive SQL utility that comes with the Open Client software on the Windows platform. If you have SQL Advantage installed, use the following procedure to run the InfoMaker stored procedure scripts.

For complete instructions on using SQL Advantage, see your Open Client documentation.

❖ **To use SQL Advantage to run the InfoMaker stored procedure scripts:**

- 1 Start the SQL Advantage utility.
- 2 Open a connection to the sybsystemprocs Adaptive Server database as the system administrator.
- 3 Open one of the following files containing the InfoMaker stored procedure script you want to run:

PBSYC.SQL
PBSYC2.SQL

- 4 Delete the use sybsystemprocs command and the go command at the beginning of each script.

SQL Advantage requires that you issue the use sybsystemprocs command by itself, with no other SQL commands following it. When you open a connection to the sybsystemprocs database in step 2, you are in effect issuing the use sybsystemprocs command. This command should not be issued again as part of the stored procedure script.

Therefore, to successfully install the stored procedures, you *must* delete the lines shown in the following table from the beginning of the InfoMaker stored procedure script *before* executing the script.

Before executing this script	Delete these lines
<i>PBSYC.SQL</i>	use sybsystemprocs go
<i>PBSYC2.SQL</i>	use sybsystemprocs go

- 5 Execute all of the statements in the SQL script.
- 6 Exit the SQL Advantage session.

About this chapter

This chapter describes how to use the native IBM Informix database interfaces in InfoMaker.

Contents

Topic	Page
Supported versions for Informix	75
Supported Informix datatypes	76
Features supported by the I10 interface	77
Basic software components for Informix	82
Preparing to use the Informix database	82
Defining the Informix database interface	84

Supported versions for Informix

You can access the IBM Informix Dynamic Server (IDS) database version 9.x or later using the InfoMaker IN9 and I10 native Informix database interfaces. You can also access Informix OnLine and Informix Standard Engine (SE) databases.

The IN9 interface in *PBIN9115.DLL* requires the Informix Client SDK 2.8.1 or later for Informix application development and Informix Connect 2.9 for runtime deployment.

The I10 interface in *PBI10115.DLL* requires the Informix Client SDK 2.9 or later for Informix application development and Informix Connect 2.9 or later for runtime deployment.

Restriction

You cannot use both the IN9 and I10 interfaces in a single InfoMaker session.

For the latest information on using InfoMaker with Informix databases, see the Sybase Support Web site at <http://www.sybase.com/detail?id=47934>.

Supported Informix datatypes

The Informix database interfaces support the Informix datatypes listed in Table 7-1 in reports and forms.

Table 7-1: Supported datatypes for Informix

Blob	LVarChar
Boolean	Money
Byte (a maximum of 2 ³¹ bytes)	NChar
Char	NVarChar
Clob	Real
Date	Serial
DateTime	Serial8
Decimal	SmallInt (2 bytes)
Float	Text (a maximum of 2 ³¹ bytes)
Int8	Time
Integer (4 bytes)	VarChar (1 to 255 bytes)
Interval	

Informix DateTime datatype

The DateTime datatype is a contiguous sequence of boxes. Each box represents a component of time that you want to record. The syntax is:

DATETIME *largest_qualifier* **TO** *smallest_qualifier*

InfoMaker defaults to Year TO Fraction(5).

For a list of qualifiers, see your Informix documentation.

❖ **To create your own variation of the DateTime datatype:**

- 1 In the Database painter, create a table with a DateTime column.

For instructions on creating a table, see the *Users Guide*.

- 2 In the Columns view, select Pending Syntax from the Objects or pop-up menu.

The Columns view displays the pending changes to the table definition. These changes execute only when you click the Save button to save the table definition.

- 3 Select Copy from the Edit or pop-up menu or click the Copy button.
The SQL syntax (or the portion you selected) is copied to the clipboard.
- 4 In the ISQL view, modify the DateTime syntax and execute the CREATE TABLE statement.

For instructions on using the ISQL view, see the *Users Guide*.

Informix Time datatype

The Informix database interfaces also support a time datatype. The time datatype is a subset of the DateTime datatype. The time datatype uses only the time qualifier boxes.

Informix Interval datatype

The interval datatype is one value or a sequence of values that represent a component of time. The syntax is:

INTERVAL *largest_qualifier* **TO** *smallest_qualifier*

InfoMaker defaults to `Day (3) TO Day`. For more about interval datatypes, see your Informix documentation.

Features supported by the I10 interface

The I10 interface supports several features that are not available when you use the IN9 interface. Some of these features require a specific version of the Informix Dynamic Server database.

Accessing Unicode data

InfoMaker can connect, save, and retrieve data in ANSI/DBCS databases using the IN9 interface, but the IN9 interface does not support Unicode databases. The Informix I10 interface supports ANSI/DBCS and Unicode databases.

The I10 native interface uses the Informix GLS (Global Language Support) API for global language support. The native interface uses three DBParms to help you set up the locale used in the current connection:

- Client_Locale
- DB_Locale
- StrByCharset

These parameters are available on the Regional Settings tab page in the Database Profile Setup dialog box.

Client_Locale

Client_Locale specifies the value of the Informix environment variable CLIENT_LOCALE. The format is *language_territory.codeset*. For example:

```
Client_Locale='en_us.1252'  
Client_Locale='en_us.utf8'
```

The I10 interface uses this setting to access string data in an Informix database and to process SQL statements. If you do not set the DBParm, the default locale value is based on the OS locale.

DB_Locale

DB_Locale specifies the value of the Informix environment variable DB_LOCALE. The format is *language_territory.codeset*. For example:

```
DB_Locale='en_us.1252'  
DB_Locale='en_us.utf8'
```

DB_LOCALE specifies the language, territory, and code set that the database server needs to correctly interpret locale-sensitive datatypes such as NChar and NVarChar in a specific database. The code set specified in DB_LOCALE determines which characters are valid in any character column, as well as in the names of database objects such as databases, tables, columns, and views. If you do not set the DBParm, the I10 interface assumes that the DB_LOCALE value is the same as the CLIENT_LOCALE value.

You can set the CLIENT_LOCALE and DB_LOCALE environment variables directly using the Informix Setnet32 utility, available in the Utilities folder for the Informix database interfaces in the Objects view in the Database painter or the Database Profiles dialog box.

For more information about the Informix CLIENT_LOCALE and DB_LOCALE environment variables, see the *IBM Informix GLS User's Guide*, currently available at the Informix library Web site at <http://publib.boulder.ibm.com/epubs/pdf/25122820.pdf>.

StrByCharset The StrByCharset DBParm specifies how to convert string data between InfoMaker Unicode strings and Informix client multibyte strings. By default, string conversion for UTF-8 code sets is based on the UTF-8 code set, and string conversion for non-UTF-8 code sets is based on the current OS code page. If StrByCharset is set to 1 (true), string conversion is based on the code set specified in the DBParm Client_Locale.

Assigning an owner to the InfoMaker catalog tables

When you use the I10 interface, you can use the PBCatalogOwner DBParm on the System tab page to assign a nondefault owner to the extended attribute system tables. For ANSI-compliant databases, the owner name that you specify must be unique but the table name does not have to be unique. You can create multiple sets of catalog tables prefaced with different user names. However, if the database is not ANSI-compliant, the table name must be unique, so that only one set of catalog tables can be created with an assigned owner name.

Support for long object names

The I10 interface supports Informix long object names with up to 128 characters.

Renaming an index

With IDS 9.2.1 and later, you can change the name of an index in the Database painter when you are connected using the I10 interface. The I10 interface uses the IDS RENAME INDEX statement to change the name of the index. You need only drop and recreate the index if you want to make other changes.

SQL statement caching

In IDS 9.2.1 and later, the database server uses the SQL statement cache (SSC) to store SQL statements across user sessions. When any user executes a statement already stored in the SQL statement cache, the database server does not parse and optimize the statement again, resulting in improved performance. The statement must be a SELECT, UPDATE, DELETE, or INSERT statement, and it cannot contain user-defined routines.

There are several ways to configure caching on the server. The SET STATEMENT CACHE statement takes precedence over the STMT_CACHE environment variable and the STMT_CACHE configuration parameter. You must enable the SQL statement cache, either by setting the STMT_CACHE configuration parameter or by using the Informix onmode utility, *before* the SET STATEMENT CACHE statement can execute successfully.

You can set the StmtCache DBParm on the System tab page in the Database Profile Setup dialog box for I10 connections to turn SQL statement caching on or off on the client. However, the server must be configured to support SQL statement caching before you can access the cache from the client.

For more information about Informix SQL statement caching, see the IBM Informix Dynamic Server Performance Guide at <http://publib.boulder.ibm.com/epubs/pdf/25122960.pdf>.

Creating and dropping indexes without locking

In IDS 10.0 and later, the SQL syntax of CREATE INDEX and DROP INDEX supports the ONLINE keyword to create or drop an index in an online environment where the database and its tables are continuously available. When you use the ONLINE keyword to create or drop an index, data definition language (DDL) operations execute without applying an exclusive lock on the table on which the specified index is defined.

If you use CREATE INDEX ONLINE to create an index on a table that other users are accessing, the index is not available until no users are updating the table.

If you issue DROP INDEX ONLINE to drop an index, no users can reference the index, but concurrent data manipulation language (DML) operations can use the index until the operations terminate. Dropping the index is deferred until no users are using the index.

You can set the OnlineIndex static DBParm on the System tab page in the Database Profile Setup dialog box for I10 connections to specify that the Database painter should use the ONLINE keyword when you create or drop an index.

Clustered index not supported

You cannot create a clustered index using online mode because it is not supported by IDS.

Column-level encryption

In IDS 10.0 and later, the SQL statement `SET ENCRYPTION PASSWORD` can improve the confidentiality of data and support data integrity by defining or resetting a password for encryption and decryption of data at the column level.

You can set the `EncryptionPass` and `Hint` static DBParms on the System tab page in the Database Profile Setup dialog box for I10 connections to specify a password and a hint to help you remember the password. The application uses built-in Informix functions to encrypt and decrypt character data.

Using multiple OUT parameters in user-defined routines

In a user-defined routine (UDR), an OUT parameter corresponds to a value returned through a pointer. Before IDS version 9.4, IDS supported no more than one OUT parameter in a UDR, and any OUT parameter was required to appear as the last item in the parameter list. IDS version 9.4 drops these restrictions, supporting multiple OUT parameters anywhere in the parameter list of the UDR. This feature is available when you use the I10 interface. It provides greater flexibility in defining UDRs, and removes the need to return collection variables in contexts where multiple returned values are required.

To return OUT parameters from a UDR, you must use statement local variables (SLVs).

In the following statement, the OUT parameter in the UDR `myfunc` is defined using the SLV syntax `slvname#out_param_type`.

```
SELECT sales FROM mytable WHERE myfunc(10, sales#money)
< 1000
```

Basic software components for Informix

Figure 7-1 shows the basic software components required to access an Informix database using the native Informix database interfaces.

Figure 7-1: Components of an Informix connection

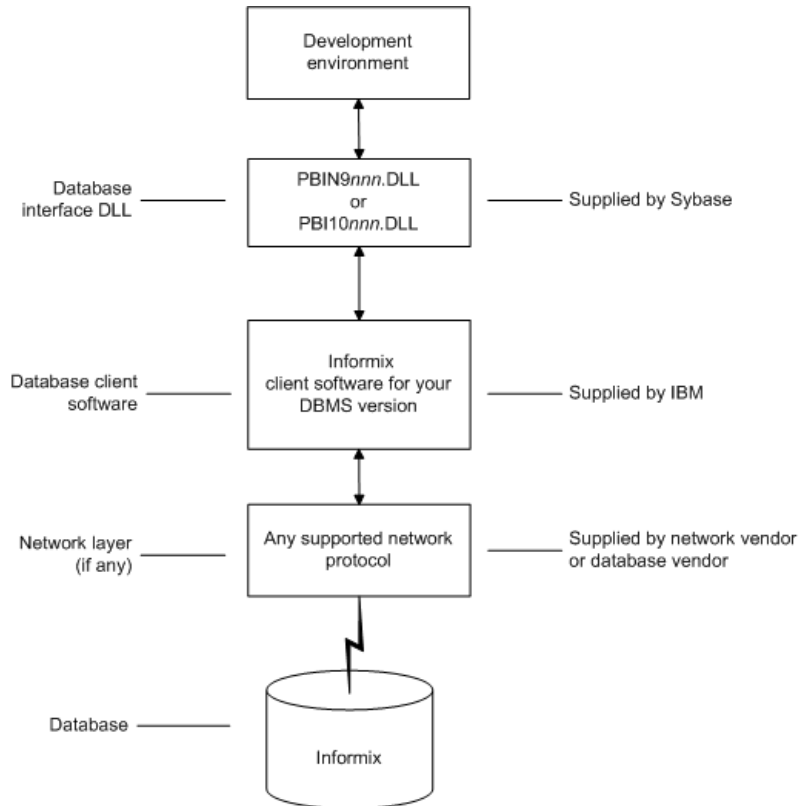

Preparing to use the Informix database

Before you define the database interface and connect to an Informix database in InfoMaker, follow these steps to prepare the database for use:

- 1 Install and configure the required database server, network, and client software.
- 2 Install the native Informix IN9 or I10 database interface.

Step 1: Install and configure the database server

- 3 Verify that you can connect to the Informix server and database outside InfoMaker.

You must install and configure the required database server, network, and client software for Informix.

❖ **To install and configure the required database server, network, and client software:**

- 1 Make sure the Informix database server software and database network software is installed and running on the server specified in your database profile.

You must obtain the database server and database network software from Informix.

For installation instructions, see your Informix documentation.

- 2 Install the required Informix client software on each client computer on which InfoMaker is installed.

Install Informix Connect or the Informix Client SDK (which includes Informix Connect).

You must obtain the Informix client software from IBM. Make sure the version of the client software you install supports *all* of the following:

- The operating system running on the client computer
- The version of the database that you want to access
- The version of InfoMaker that you are running

For installation instructions, see your Informix documentation.

- 3 Make sure the Informix client software is properly configured so that you can connect to the Informix database server at your site.

Run the SetNet32 utility to configure the client registry settings. When you configure Informix Connect client software, it creates a registry entry in *HKEY_LOCAL_MACHINE\Software\Informix\SqlHosts*. The registry entry contains parameters that define your network configuration, network protocol, and environment variables. If you omit these values from the database profile when you define the native Informix database interface, they default to the values specified in the registry entry.

For instructions on configuring your Informix client software, see your Informix documentation.

- 4 If required by your operating system, make sure the directory containing the Informix client software is in your system path.

Step 2: Install the database interface

In the InfoMaker Setup program, select the Typical install, or select the native Informix database interface in the Custom install.

Step 3: Verify the connection

Make sure you can connect to the Informix server and database you want to access from outside InfoMaker.

To verify the connection, use any Windows-based utility (such as the Informix `ilogin.exe` program) that connects to the database. When connecting, be sure to specify the same parameters you plan to use in your InfoMaker database profile to access the database.

For instructions on using `ilogin.exe`, see your Informix documentation.

Defining the Informix database interface

To define a connection through an Informix database interface, you must create a database profile by supplying values for at least the basic connection parameters in the Database Profile Setup dialog box for Informix IN9 or I10. You can then select this profile at any time to connect to your database in the development environment.

For information on how to define a database profile, see “Using database profiles” on page 6.

Specifying the server name

When you specify the server name value, you *must* use the following format to connect to the database through the Informix interfaces:

host_name@server_name

Parameter	Description
<i>host_name</i>	The name of the host computer running the Informix database server. This corresponds to the Informix HOSTNAME environment variable.
<i>server_name</i>	The name of the server containing the Informix database. This corresponds to the Informix SERVER environment variable.

For example, to use the a native interface to connect to an Informix database server named `server01` running on a host machine named `sales`, type the host name (`sales`) in the Host Name box and the server name (`server01`) in the Server box on the Connection tab in the Database Profile Setup dialog box. InfoMaker saves this server name as `sales@server01` in the database profile entry in the system registry.

About this chapter

This chapter describes how to use the Microsoft SQL Server Native Client database interface in InfoMaker.

Contents

Topic	Page
Supported versions for SQL Server	87
Supported SQL Server datatypes	88
Basic software components for Microsoft SQL Server	89
Preparing to use the SQL Server database	89
Defining the SQL Server database interface	91
Migrating from the MSS or OLE DB database interfaces	92
SQL Server 2005 features	95
SQL Server 2008 features	95
Notes on using the SNC interface	103

Supported versions for SQL Server

You can access Microsoft SQL Server 2000 and 2005 databases using the SQL Native Client interface. The SQL Native Client interface uses a DLL named *PBSNC115.DLL* to access the database. The interface uses the SQL Server 2005 Native Client (*sqlncli.h* and *sqlncli.dll*) on the client side and connects using OLE DB.

For SQL Server 2000, the SQL client SDK was provided with the Microsoft Database Access Components (MDAC). MDAC does not support new features in SQL Server 2005. To take advantage of these features, you need to use the SNC interface. The SQL Server 2005 SQL Native Client software must be installed on the client computer.

PBODB initialization file not used

Connections made directly through OLE DB use the PBODB initialization file to set some parameters, but connections made using the SNC interface do not depend on the PBODB initialization file.

Supported SQL Server datatypes

The SQL Native Client database interface supports the datatypes listed in Table 8-1.

Table 8-1: Supported datatypes for Microsoft SQL Server 2005

Binary	Real
Bit	SmallDateTime
Character (fewer than 255 characters)	SmallInt
DateTime	SmallMoney
Decimal	Text
Float	Timestamp
Identity	TinyInt
Image	VarBinary(max)
Int	VarBinary(n)
Money	VarChar(max)
Numeric	VarChar(n)
NVarChar(max)	XML
NVarChar(n)	

The XML datatype is a built-in datatype in SQL Server 2005 that enables you to store XML documents and fragments in a SQL Server database. You can use this datatype as a column type when you create a table.

Additional datatypes are supported for SQL Server 2008. For more information, see “Support for new datatypes in SQL Server 2008” on page 97.

In SQL Server 2005, the VarChar(max), NVarChar(max), and VarBinary(max) datatypes store very large values (up to 2³¹ bytes). You can use these datatypes to obtain metadata, define new columns, and query data from the columns. You can also use them to pipeline data.

Basic software components for Microsoft SQL Server

You must install the software components in Figure 8-1 to access a database with the SQL Native Client interface. Microsoft SQL Server Native Client software contains a SQL OLE DB provider and ODBC driver in a single DLL.

Figure 8-1: Components of a Microsoft SQL Server connection

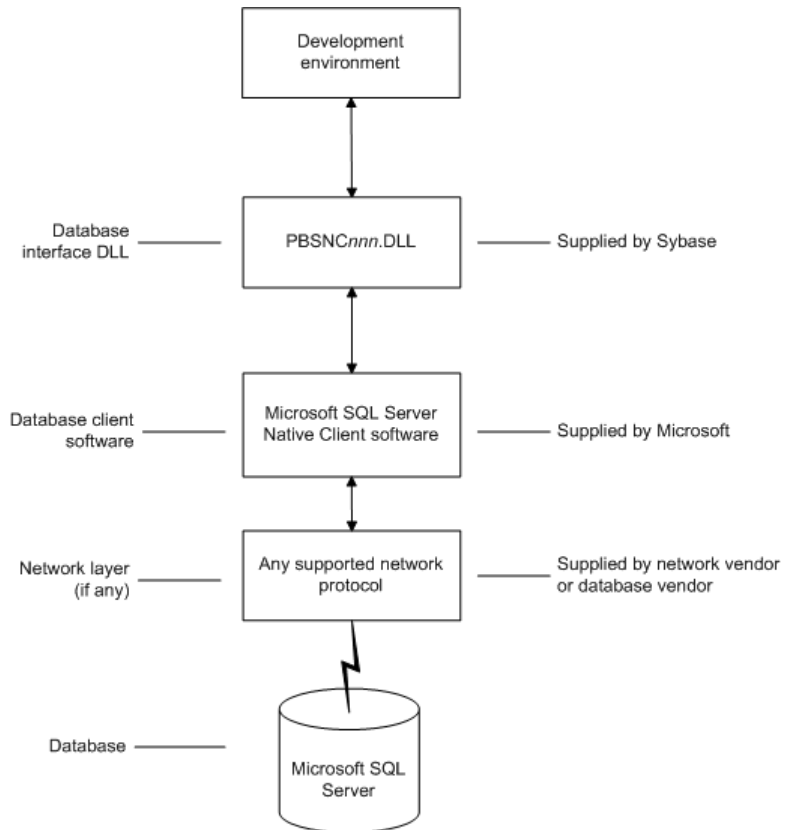

Preparing to use the SQL Server database

Before you define the database interface and connect to a Microsoft SQL Server database in InfoMaker, follow these steps to prepare the database for use:

Step 1: Install and configure the database server

- 1 Install and configure the required database server, network, and client software.
- 2 Install the SQL Native Client database interface.
- 3 Verify that you can connect to the Microsoft SQL Server server and database outside InfoMaker.

You must install and configure the database server, network, and client software for SQL Server.

❖ **To install and configure the database server, network, and client software:**

- 1 Make sure the Microsoft SQL Server database software is installed and running on the server specified in your database profile.

You must obtain the database server software and required licenses from Microsoft Corporation. For installation instructions, see your Microsoft SQL Server documentation.

Upgrading from an earlier version of SQL Server

For instructions on upgrading to a later version of SQL Server or installing it alongside an earlier version, see your Microsoft SQL Server documentation.

- 2 If you are accessing a remote SQL Server database, make sure the required network software (for example, TCP/IP) is installed and running on your computer and is properly configured so that you can connect to the SQL Server database server at your site.

For installation and configuration instructions, see your network or database administrator.

- 3 Install the required Microsoft SQL Native Client software on each client computer on which InfoMaker is installed.

You must obtain the SQL Native Client software from Microsoft. Make sure the version of the client software you install supports *all* of the following:

- The operating system running on the client computer
- The version of the database that you want to access
- The version of InfoMaker that you are running

For installation instructions, see your Microsoft SQL Server documentation.

- 4 Make sure the SQL Native Client client software is properly configured so that you can connect to the SQL Server database server at your site.
For configuration instructions, see your Microsoft SQL Server documentation.
- 5 Make sure the directory containing the SQL Native Client software is in your system path.
- 6 Make sure only one copy of the *Sqlncli.dll* file is installed on your computer.

Step 2: Install the database interface

In the InfoMaker Setup program, select the Custom install and select the SQL Native Client database interface.

Step 3: Verify the connection

Make sure you can connect to the SQL Server server and database you want to access from outside InfoMaker.

To verify the connection, use any Windows-based utility that connects to the database. When connecting, be sure to specify the same parameters you plan to use in your InfoMaker database profile to access the database.

Defining the SQL Server database interface

To define a connection through the SQL Native Client interface, you must create a database profile by supplying values for at least the basic connection parameters in the Database Profile Setup - SQL Native Client dialog box. You can then select this profile at any time to connect to your database in the development environment.

For information on how to define a database profile, see “Creating a database profile” on page 9. For new features that require special settings in the database profile, see “SQL Server 2005 features” on page 95. For a comparison of the database parameters you might have used with existing applications and those used with the SNC database interface, see “Migrating from the MSS or OLE DB database interfaces” next.

Migrating from the MSS or OLE DB database interfaces

In earlier releases of InfoMaker, the MSS native interface was provided for connection to Microsoft SQL Server. This native interface was based on Microsoft DB-LIB functionality, which is no longer supported by Microsoft and is not Unicode-enabled. The MSS interface was removed in InfoMaker 10.0.

Prior to the introduction of SQL Server 2005 and SQL Native Client, Microsoft recommended using the OLE DB database interface and MDAC to connect to SQL Server. You can continue to use this solution if you do not need to take advantage of new features in SQL Server 2005 or SQL Server 2008.

This section provides a comparison between database parameters you might have used in existing applications with the parameters you can use with the SNC database interface.

MSS database parameters supported by SNC

Table 8-2 shows the database parameters and preferences that could be set in the Database Profile Setup dialog box for the discontinued MSS native database interface for Microsoft SQL Server, and indicates whether they are supported by the SNC interface.

The column on the left shows the tab page in the Database Profile Setup dialog box for MSS. The parameters and preferences may be on different tab pages in the SNC profile.

Table 8-2: MSS parameters supported by SNC

MSS	SNC
Connection tab:	
Language	Not supported
Lock	Supported (Transaction tab)
AutoCommit	Supported
CommitOnDisconnect	Supported
System tab:	
Log	Not supported
SystemProcs	Not supported
PBCatalogOwner	Supported
Transaction tab:	
Async	Not supported
DBGetTime	Not supported
CursorLock	Not supported
CursorScroll	Not supported
StaticBind	Supported

MSS	SNC
MaxConnect	Not supported
Syntax tab:	
DBTextLimit	Supported (as PBMaxTextSize on Transaction tab)
DateTimeAllowed	Not supported
OptSelectBlob	Not supported
Network tab:	
AppName	Supported (System tab)
Host	Supported (System tab)
PacketSize	Supported (System tab)
Secure	Supported (as TrustedConnection on General tab)

OLE DB database parameters supported by SNC

Table 8-3 shows the database parameters and preferences that can be set in the Database Profile Setup dialog box for the OLE DB standard interface for Microsoft SQL Server, and indicates whether they are supported by the SNC interface.

The column on the left shows the tab page in the Database Profile Setup dialog box for OLE DB. The parameters and preferences may be on different tab pages in the SNC profile.

Table 8-3: OLE DB parameters supported by SNC

OLE DB	SNC
Connection tab:	
Provider	Not supported
DataSource	Supported at runtime (as SQLCA.ServerName)
DataLink	Supported
Location	Not supported
ProviderString	Supported
System tab:	
PBCatalogOwner	Supported
ServiceComponents	Not supported
AutoCommit	Supported (General tab)
CommitOnDisconnect	Supported (General tab)
StaticBind	Supported (Transaction tab)
DisableBind	Supported (Transaction tab)
Init_Prompt	Not supported
TimeOut	Supported
LCID	Not supported

OLE DB	SNC
Transaction tab:	
Block	Supported
PBMaxBlobSize	Supported
Mode	Not supported
Lock	Supported
Syntax tab:	
DelimitIdentifier	Supported
IdentifierQuoteChar	Not supported
DateFormat	Supported
TimeFormat	Supported
DecimalSeparator	Supported
OJSyntax	Supported
Security tab:	
EncryptPassword	Not supported
CacheAuthentication	Not supported
PersistSensitive	Not supported
MaskPassword	Not supported
PersistEncrypted	Not supported
IntegratedSecurity	Supported (TrustedConnection on General tab)
ImpersonationLevel	Not supported
ProtectionLevel	Not supported

Additional database parameters

The SNC interface also supports the Encrypt, TrustServerCertificate, and SPCache parameters (on the System tab page) and the Identity parameter (on the Syntax tab page).

SPCache database parameter

You can control how many stored procedures are cached with parameter information by modifying the setting of the SPCache database parameter. The default is 100 procedures. To turn off caching of stored procedures, set SPCache to 0.

For more information about database parameters supported by the SNC interface, see the *Connection Reference* in the online Help.

SQL Server 2005 features

The SNC database interface supports several features that were introduced in SQL Server 2005. For more information about using these features, see the Microsoft SQL Server 2005 documentation.

Multiple Active Result Sets

The SNC interface supports Multiple Active Result Sets (MARS), which enable applications to have multiple default result sets open and to interleave reading from them. Applications can also execute statements such as INSERT, UPDATE, and DELETE and stored procedure calls while default result sets are open.

Encryption without validation

SQL Server 2005 always encrypts network packets associated with logging. If no certificate is provided on the server when it starts up, SQL Server generates a self-signed certificate that is used to encrypt login packets.

The SQL Native Client supports encrypting data sent to the server without validating the certificate. The TrustServerCertificate database parameter, available on the System page of the database connection profile dialog box, allows you to control this feature.

Snapshot isolation

The snapshot isolation level is designed to enhance concurrency for online transaction processing applications. Transactions that start under snapshot isolation read a database snapshot taken at start up time. Keyset, dynamic, and static server cursors in this context behave like static cursors opened within serializable transactions, but locks are not taken, which can reduce blocking on the server. The SQLCA.Lock value for snapshot isolation is SS. You can set this value in the Isolation Level field on the Transaction page of the database connection profile dialog box.

SQL Server 2008 features

InfoMaker support for connections to SQL Server 2008 databases includes new database parameters as well as support for new SQL Server datatypes. To connect to SQL Server 2008 from InfoMaker, you must install the SNC 10.0 driver.

New database parameters

Provider parameter The Provider DBParm parameter for the SQL Native Client (SNC) interface allows you to select the SQL Server version that you want to connect to. You can set this parameter in script to SQLNCLI (for the SNC 9.0 driver that connect to SQL Server 2005) or to SQLNCLI10 (for the SNC 10.0 driver that connects to SQL Server 2008). Otherwise, you can select one of these providers on the Connection tab of the Database Profile Setup dialog box for the SNC interface.

If you do not set or select a provider, the default selection is SQLNCLI (SNC 9.0 for SQL Server 2005). This allows existing SNC interface users to be able to migrate to InfoMaker 11.5 without any modifications. If InfoMaker fails to connect with the SQLNCLI provider, it will attempt to connect to SQLNCLI10 provider. However, if you explicitly set the provider and the connection fails, InfoMaker displays an error message.

Failover parameter The FailoverPartner DBParm parameter allows you to set the name of a mirror server, thereby maintaining database availability if a failover event occurs. You can also set the name of the mirror server on the System tab of the Database Profile Setup dialog box for the SNC interface.

When failover occurs, the existing InfoMaker connection to SQL Server is lost. The SNC driver releases the existing connection and tries to reopen it. If reconnection succeeds, InfoMaker triggers the failover event.

The following conditions must be satisfied for InfoMaker to trigger the failover event:

- The FailoverPartner DBParm is supplied at connect time
- The SQL Server database is configured for mirroring
- InfoMaker is able to reconnect successfully when the existing connection is lost

When failover occurs:

- InfoMaker returns an error code (998) and triggers the failover event
- Existing cursors cannot be used and should be closed
- Any failed database operation can be tried again
- Any uncommitted transaction is lost. New transactions must be started

Support for new datatypes in SQL Server 2008

Date and time datatypes

The following table lists new SQL Server 2008 date and time datatypes and the PowerScript datatypes that they map to:

SQL Server datatype	PowerScript datatype
DATE	Date
TIME	Time (Supports only up to 6 fractional seconds precision although SQL Server datatype supports up to 7 fractional seconds precision.)
DATETIME2	DateTime (Supports only up to 6 fractional seconds precision although SQL Server datatype supports up to 7 fractional seconds precision.)

The SQL Server 2008 DATETIMEOFFSET datatype is not supported in InfoMaker 11.5.

Precision settings When you map to a table column in a SQL Server 2008 database, InfoMaker includes a column labeled “Dec” in the Column Specifications view of the Report painter, and a text box labeled “Fractional Seconds Precision” in the Column (Object Details) view of the Database painter. These fields allow you to list the precision that you want for the TIME and DATETIME2 columns..

The precision setting is for table creation only. When retrieving or updating the data in a column, InfoMaker uses only up to six decimal places precision for fractional seconds, even if you enter a higher precision value for the column.

Filestream datatype

The FILESTREAM datatype allows large binary data to be stored directly in an NTFS file system. Transact-SQL statements can insert, update, query, search, and back up FILESTREAM data.

The SQL Server Database Engine implements FILESTREAM as a Varbinary(max) datatype. The InfoMaker SNC interface maps the Varbinary(max) datatype to a BLOB datatype, so to retrieve or update filestream data, use the SelectBlob or UpdateBlob SQL statements, respectively. To specify that a column should store data on the file system, you must include the FILESTREAM attribute in the Varbinary(max) column definition. For example:

```
CREATE TABLE FSTest (
    GuidCol1 uniqueidentifier ROWGUIDCOL NOT NULL
    UNIQUE DEFAULT NEWID(),
    IntCol2 int,
    varbinaryCol3 varbinary(max) FILESTREAM);
```

Do not use PowerScript file access functions with FILESTREAM data

You can access FILESTREAM data by declaring and using the Win32 API functions directly in InfoMaker applications. However, existing InfoMaker file access functions cannot be used to access FILESTREAM files. For more information about accessing FILESTREAM data using Win32 APIs, see the MSDN SQL Server Developer Center Web site at [http://msdn.microsoft.com/en-us/library/bb933877\(SQL.100\).aspx](http://msdn.microsoft.com/en-us/library/bb933877(SQL.100).aspx).

Using CLR datatypes
in InfoMaker

The binary values of the .NET Common Language Runtime (CLR) datatypes can be retrieved from a SQL Server database as blobs that you could use in InfoMaker applications to update other columns in the database. If their return values are compatible with InfoMaker datatypes, you can use CLR datatype methods in PowerScript, dynamic SQL, embedded SQL or in report objects, because the SQL script is executed on the SQL Server side.

The CLR datatypes can also be mapped to Strings in PowerScript, but the retrieved data is a hexadecimal string representation of binary data.

You can use the ToString method to work with all datatypes that are implemented as CLR datatypes, such as the HierarchyID datatype, Spatial datatypes, and User-defined types.

HierarchyID datatype

HierarchyID is a variable length, system datatype that can store values representing nodes in a hierarchical tree, such as an organizational structure. A value of this datatype represents a position in the tree hierarchy.

ISQL Usage You can use HierarchyID columns with CREATE TABLE, SELECT, UPDATE, INSERT, and DELETE statements in the ISQL painter. For example:

```
CREATE TABLE Emp (  
    EmpId int NOT NULL,  
    EmpName varchar(20) NOT NULL,  
    EmpNode hierarchyid NULL);
```

To insert HierarchyID data, you can use the canonical string representation of HierarchyID or any of the methods associated with the HierarchyID datatype as shown below.

```
INSERT into Emp VALUES (1, 'Scott',  
    hierarchyid::GetRoot());  
INSERT into Emp VALUES (2, 'Tom' , '/1/');
```

```
DECLARE @Manager hierarchyid  
SELECT @Manager = hierarchyid::GetRoot() FROM Emp  
INSERT into Emp VALUES (2, 'Tom',
```

```

@Manager.GetDescendant(NULL,NULL);
DECLARE @Employee hierarchyid
SELECT @Employee = CAST('/1/2/3/4/' AS hierarchyid)
INSERT into Emp VALUES (2, 'Jim' , @Employee);

```

You cannot select the HierarchyID column directly since it has binary data, and the ISQL painter Results view does not display binary columns. However, you can retrieve the HierarchyID data as a string value using the ToString method of HierarchyID. For example:

```
Select EmpId, EmpName, EmpNode.ToString() from Emp;
```

You can also use the following methods on HierarchyID columns to retrieve its data: GetAncestor, GetDescendant, GetLevel, GetRoot, IsDescendant, Parse, and Reparent. If one of these methods returns a HierarchyID node, then use ToString to convert the data to a string. For example:

```
Select EmpId, EmpName, EmpNode.GetLevel() from Emp;
Select EmpId, EmpName,
EmpNode.GetAncestor(1).ToString() from Emp;
```

HierarchyID columns can be updated using a String value or a HierarchyID variable:

```
Update Emp Set EmpNode = '/1/2/' where EmpId=4;
Delete from Emp where EmpNode = '/1/2/';
```

PowerScript Usage You can use HierarchyID columns in embedded SQL statements for SELECT, INSERT, UPDATE, and DELETE operations. HierarchyID data can be retrieved either as a String or as a Binary(Blob) datatype using the SelectBlob statement.

When using a String datatype to retrieve HierarchyID data, use the ToString method. Otherwise the data will be a hexadecimal representation of the binary HierarchyID value.

The following example shows how you can use HierarchyID methods in embedded SQL:

```

long id
String hid,name
Select EmpId, EmpName, EmpNode.ToString()
into :id, :name, :hid
from Emp where EmpId=3;
Select EmpId, EmpName, EmpNode.GetLevel()
into :id, :name, :hid
from Emp where EmpId=3;
Blob b
Selectblob EmpNode into :b from Emp where EmpId =2;

```

DataWindow Usage Reports do not directly support the HierarchyID datatype. But you can convert the HierarchyID to a string using the ToString method or an associated HierarchyID method in the data source SQL. For example:

```
SELECT EmpId, EmpName, EmpNode.ToString() FROM Emp;  
SELECT EmpId, EmpName, EmpNode.GetLevel() FROM Emp;
```

Spatial datatypes

Microsoft SQL Server 2008 supports two spatial datatypes: the geometry datatype and the geography datatype. In SQL Server, these datatypes are implemented as .NET Common Language Runtime (CLR) datatypes.

Although the InfoMaker SNC interface does not work with CLR datatypes, you can convert the spatial datatypes into strings (with the ToString function) and use them in PowerScript, in the ISQL painter, in embedded SQL, and in reports. This is similar to the way you use the HierarchyID datatype. The SelectBlob SQL statement also lets you retrieve binary values for these datatypes.

The geography and geometry datatypes support eleven different data objects, or instance types, but only seven of these types are instantiable: Points, LineStrings, Polygons, and the objects in an instantiable GeometryCollection (MultiPoints, MultiLineStrings, and MultiPolygons). You can create and work with these objects in a database, calling methods associated with them, such as STAsText, STArea, STGeometryType, and so on. For example:

```
CREATE TABLE SpatialTable (id int IDENTITY (1,1),  
    GeomCol geometry);  
INSERT INTO SpatialTable (GeomCol) VALUES (  
    geometry::STGeomFromText(  
        'LINESTRING (100 100,20 180,180 180)',0));  
select id, GeomCol.ToString() from SpatialTable;  
select id, GeomCol.STAsText(),  
    GeomCol.STGeometryType(),  
    GeomCol.STArea() from SpatialTable;
```

User-defined types

User-defined types (UDTs) are implemented in SQL Server as CLR types and integrated with .NET. Microsoft SQL Server 2008 eliminates the 8 KB limit for UDTs, enabling the size of UDT data to expand dramatically.

Although the InfoMaker SNC interface does not directly support UDT datatypes, you can use the ToString method to retrieve data for UDTs in the same way as for other CLR datatypes such as HierarchyId or the spatial datatypes. However, if a UDT datatype is mapped to a String datatype in PowerScript, UDT binary values will be retrieved as hexadecimal strings. To retrieve or update data in binary form (blob) from a UDT, you can use the SelectBlob or UpdateBlob SQL statements, respectively.

You can use any of the associated methods of UDT or CLR datatypes that return compatible data (such as String, Long, Decimal, and so on) for InfoMaker applications.

T-SQL enhancements

MERGE statement

The MERGE Transact-SQL statement performs INSERT, UPDATE, or DELETE operations on a target table or view based on the results of a join with a source table. You can use MERGE statement in the ISQL painter and in PowerScript using dynamic SQL. For example

```
String mySQL
mySQL = "MERGE INTO a USING b ON a.keycol = b.keycol " &
+ "WHEN MATCHED THEN "&
+ "UPDATE SET col1 = b.col1,col2 = b.col2 " &
+ "WHEN NOT MATCHED THEN " &
+ "INSERT (keycol, col1, col2, col3) " &
+ "VALUES (b.keycol, b.col1, b.col2, b.col3) " &
+ "WHEN SOURCE NOT MATCHED THEN " &
+ "DELETE;"
EXECUTE IMMEDIATE :MySql;
```

Using the MERGE statement in ISQL

A MERGE statement must be terminated by a semicolon. By default the ISQL painter uses a semicolon as a SQL terminating character, so to use a MERGE statement in ISQL, the terminating character must be changed to a colon (:), a forward slash (/), or some other special character.

Grouping sets

GROUPING SETS is an extension of the GROUP BY clause that lets you define multiple groupings in the same query. GROUPING SETS produce a single result set, making aggregate querying and reporting easier and faster. It is equivalent to a UNION ALL operation for differently grouped rows.

The GROUPING SETS, ROLLUP, and CUBE operators are added to the GROUP BY clause. A new function, GROUPING_ID, returns more grouping-level information than the existing GROUPING function. (The WITH ROLLUP, WITH CUBE, and ALL syntax is not ISO compliant and is therefore deprecated.)

The following example uses the GROUPING SETS operator and the GROUPING_ID function:

```
SELECT EmpId, Month, Yr, SUM(Sales) AS Sales
FROM Sales
```

```
GROUP BY GROUPING SETS((EmpId, ROLLUP(Yr, Month)));  
SELECT COL1, COL2,  
SUM(COL3) AS TOTAL_VAL,  
GROUPING(COL1) AS C1,  
GROUPING(COL2) AS C2,  
GROUPING_ID(COL1, COL2) AS GRP_ID_VALUE  
FROM TEST_TBL GROUP BY ROLLUP (COL1, COL2);
```

You can use the **GROUPING SETS** operator in the ISQL painter, in PowerScript (embedded SQL and dynamic SQL) and in reports (syntax mode).

Row constructors

Transact-SQL now allows multiple value inserts within a single **INSERT** statement. You can use the enhanced **INSERT** statement in the ISQL painter and in PowerScript (embedded SQL and dynamic SQL). For example:

```
INSERT INTO Employees VALUES ('tom', 25, 5),  
('jerry', 30, 6), ('bok', 25, 3);
```

When including multiple values in a single **INSERT** statement with host variables, you must set the **DisableBind DBParm** to 1. If you use literal values as in the above example, you can insert multiple rows in a single **INSERT** statement regardless of the binding setting.

Compatibility level

In SQL Server 2008, the **ALTER DATABASE** statement allows you to set the database compatibility level (SQL Server version), replacing the **sp_dbcmptlevel** procedure. You can use this syntax in the ISQL painter and in PowerScript (dynamic SQL). For example:

```
ALTER DATABASE <database_name>  
SET COMPATIBILITY_LEVEL = {80 | 90 | 100}  
80 = SQL Server 2000  
90 = SQL Server 2005  
100 = SQL Server 2008
```

Compatibility level affects behaviors for the specified database only, not for the entire database server. It provides only partial backward compatibility with earlier versions of SQL Server. You can use the database compatibility level as an interim migration aid to work around differences in the behaviors of different versions of the database.

Table hints

The **FORCESEEK** table hint overrides the default behavior of the query optimizer. It provides advanced performance tuning options, instructing the query optimizer to use an index seek operation as the only access path to the data in the table or view that is referenced by the query. You can use the **FORCESEEK** table hint in the ISQL painter, in PowerScript (embedded SQL and dynamic SQL), and in reports (syntax mode).

For example:

```
Select ProductID, OrderQty from SalesOrderDetail
with (FORCESEEK);
```

Unsupported SQL Server 2008 features

The InfoMaker SNC interface does not support the User-Defined Table Type (a user-defined type that represents the definition of a table structure) that was introduced in SQL Server 2008.

Notes on using the SNC interface

SQL batch statements The SNC interface supports SQL batch statements. However, they must be enclosed in a BEGIN...END block or start with the keyword DECLARE:

- Enclosed in a BEGIN...END block:

```
BEGIN
INSERT INTO t_1 values(1, 'sfdfs')
INSERT INTO t_2 values(1, 'sfdfs')
SELECT * FROM t_1
SELECT * FROM t_2
END
```

- Starting with the keyword DECLARE:

```
DECLARE @p1 int, @p2 varchar(50)
SELECT @p1 = 1
EXECUTE sp_4 @p1, @p2 OUTPUT
SELECT @p2 AS 'output'
```

You can run the batch of SQL statements in the Database painter. For example:

```
String batchSQL //contains a batch of SQL statements
DECLARE my_cursor DYNAMIC CURSOR FOR SQLSA ;
PREPARE SQLSA FROM :batchSQL ;
OPEN DYNAMIC my_cursor ;
//first result set
FETCH my_cursor INTO . . .
//second result set
FETCH my_cursor INTO . .
. . .
CLOSE my_cursor ;
```

Connection pooling The SNC interface pools connections automatically using OLE DB pooling. To disable OLE DB pooling, type the following in the Extended Properties box on the Connection tab page in the Database Profile Setup dialog box:

`OLE DB Services=-4`

Triggers and synonyms in the Database painter In the Objects view for SNC profiles in the Database painter, triggers display for tables in the Tables folder and Microsoft SQL Server 2005 synonyms display for tables and views.

About this chapter

This chapter describes how to use the native Oracle database interfaces in InfoMaker.

Contents

Topic	Page
Supported versions for Oracle	105
Supported Oracle datatypes	106
Basic software components for Oracle	108
Preparing to use the Oracle database	109
Defining the Oracle database interface	113
Using Oracle stored procedures as a data source	114
Using Oracle user-defined types	118
ORA driver support for Oracle 11g features	120

Supported versions for Oracle

InfoMaker provides three Oracle database interfaces. These interfaces use different DLLs and access different versions of Oracle.

Table 9-1: Supported native database interfaces for Oracle

Oracle interface	DLL
O90 Oracle9i	<i>PBO90115DLL</i>
O10 Oracle 10g	<i>PBO10115.DLL</i>
ORA Oracle 11g	<i>PBORA115.DLL</i>

Support for the O84 Oracle8i interface is discontinued in InfoMaker 11.5.

For more information

Updated information about supported versions of Oracle might be available electronically on the Sybase Support and Downloads Web site at <http://www.sybase.com/detail?id=1011566> or in the InfoMaker Release Bulletin.

The OI database interface allows you to connect to Oracle 11g servers using Oracle 11g Database Client or Oracle 11g Instant Client. It includes partial support for the XMLType datatype that it maps to the InfoMaker String datatype. It also supports session and connection pooling, load balancing, the Oracle Client Cache, setting of an application driver name, and access through a proxy. Oracle 11g clients can also connect to Oracle9i or Oracle 10g servers.

The O10 database interface allows you to connect to Oracle 10g servers using Oracle 10g Database Client or Oracle 10g Instant Client. It supports BINARY_FLOAT and BINARY_DOUBLE datatypes and increased size limits for CLOB and NCLOB datatypes. Oracle 10g clients can connect to Oracle9i or Oracle 10g servers; they cannot connect to Oracle8i or earlier servers.

Supported Oracle datatypes

The Oracle database interfaces support the Oracle datatypes listed in Table 9-2 in reports.

Table 9-2: Supported datatypes for Oracle

Binary_Float (Oracle 10g and later only)	LongRaw
Binary_Double (Oracle 10g and later only)	NChar
Bfile	Number
Blob	NVarChar2
Char	Raw
Clob	TimeStamp
Date	VarChar
Float	VarChar2
Long	XMLType (partial support, OI driver only)

The OI driver adds support for the XMLType datatype that was introduced with Oracle 9i. However, you cannot use this datatype with embedded SQL statements or in a report.

Accessing Unicode data

InfoMaker can connect, save, and retrieve data in both ANSI/DBCS and Unicode databases, but it does not convert data between Unicode and ANSI/DBCS. When character data or command text is sent to the database, InfoMaker sends a Unicode string. The driver must guarantee that the data is saved as Unicode data correctly. When InfoMaker retrieves character data, it assumes the data is Unicode.

A Unicode database is a database whose character set is set to a Unicode format, such as UTF-8, UTF-16, UCS-2, or UCS-4. All data must be in Unicode format, and any data saved to the database must be converted to Unicode data implicitly or explicitly.

A database that uses ANSI (or DBCS) as its character set might use special datatypes to store Unicode data. These datatypes are NCHAR and NVARCHAR2. Columns with this datatype can store *only* Unicode data. Any data saved into such a column must be converted to Unicode explicitly. This conversion must be handled by the database server or client.

A constant string is regarded as a char type by Oracle and its character set is NLS_CHARACTERSET. However, if the datatype in the database is NCHAR and its character set is NLS_NCHAR_CHARACTERSET, Oracle performs a conversion from NLS_CHARACTERSET to NLS_NCHAR_CHARACTERSET. This can cause loss of data. For example, if NLS_CHARACTERSET is WE8ISO8859P1 and NLS_NCHAR_CHARACTERSET is UTF8, when the Unicode data is mapped to WE8ISO8859P1, the Unicode data is corrupted.

By default, the Oracle database interfaces bind all string data to internal variables as the Oracle CHAR datatype to avoid downgrading performance. To ensure that NCHAR and NVARCHAR2 columns are handled as such on the server, set the NCharBind database parameter to 1 to have the drivers bind string data as the Oracle NCHAR datatype.

If an Oracle stored procedure has an NCHAR or NVARCHAR2 input parameter and the input data is a Unicode string, set the BindSPInput database parameter to 1 to force the Oracle database to bind the input data. The Oracle database interfaces are able to describe the procedure to determine its parameters, therefore you do not need to set the NCharBind database parameter.

For a report to access NCHAR and NVARCHAR2 columns and retrieve data correctly, set both DisableBind and StaticBind to 0. Setting StaticBind to 0 ensures that InfoMaker gets an accurate datatype before retrieving.

TimeStamp datatype

The TimeStamp datatype in Oracle9i and later is an extension of the Date datatype. It stores the year, month, and day of the Date value plus hours, minutes, and seconds:

```
Timestamp[fractional_seconds_precision]
```

The *fractional_seconds_precision* value is optional and provides the number of digits for indicating seconds. The range of valid values for use with InfoMaker is 0-6.

Basic software components for Oracle

You must install the software components in Figure 9-1 to access an Oracle database in InfoMaker.

Figure 9-1: Components of an Oracle connection

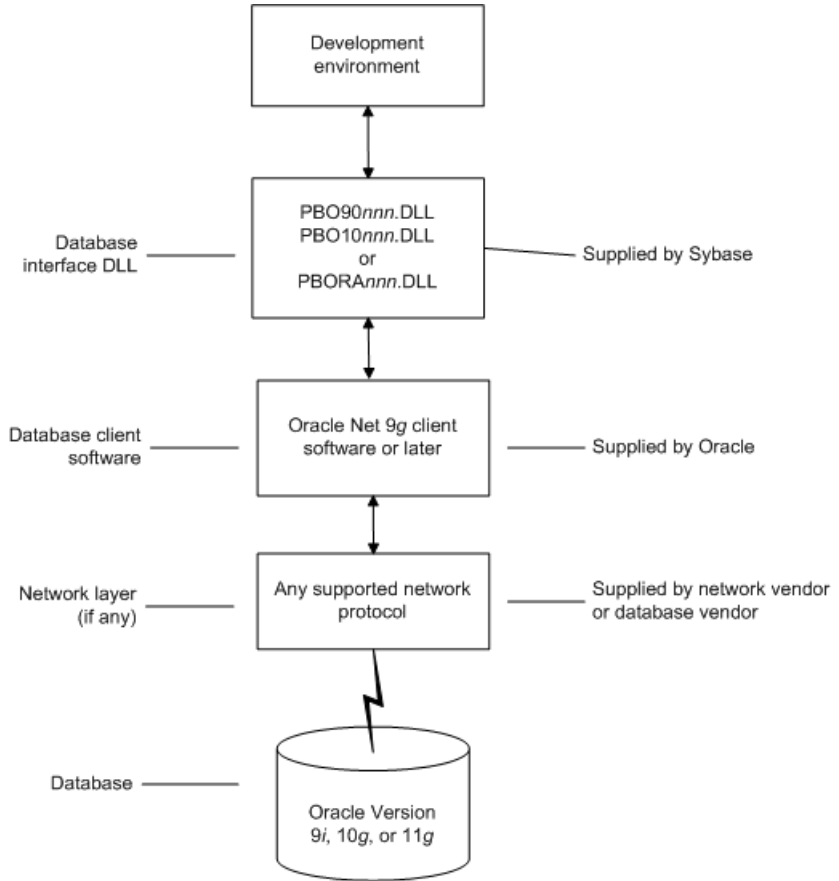

Preparing to use the Oracle database

Before you define the database interface and connect to an Oracle database in InfoMaker, follow these steps to prepare the database for use:

- 1 Install and configure the required database server, network, and client software.
- 2 Install the native Oracle database interface for the version of Oracle you want to access.
- 3 Verify that you can connect to the Oracle server and database outside InfoMaker.
- 4 (ORA driver only) Determine whether you want to use connection pooling or session pooling.

Preparing an Oracle database for use with InfoMaker involves these basic tasks.

Step 1: Install and configure the database server

You must install and configure the database server, network, and client software for Oracle.

❖ **To install and configure the database server, network, and client software:**

- 1 Make sure the Oracle database software is installed on your computer or on the server specified in your database profile.

For example, with the Oracle O90 interface you can access an Oracle9i or Oracle 10g database server.

You must obtain the database server software from Oracle Corporation.

For installation instructions, see your Oracle documentation.

- 2 Make sure the supported network software (such as TCP/IP) is installed and running on your computer and is properly configured so that you can connect to the Oracle database server at your site.

The Hosts and Services files must be present on your computer and properly configured for your environment.

You must obtain the network software from your network vendor or database vendor.

For installation and configuration instructions, see your network or database administrator.

- 3 Install the required Oracle client software on each client computer on which InfoMaker is installed.

You must obtain the client software from Oracle Corporation. Make sure the client software version you install supports *all* of the following:

- The operating system running on the client computer
- The version of the database that you want to access
- The version of InfoMaker that you are running

Oracle 10g Instant Client is free client software that lets you run applications without installing the standard Oracle client software. It has a small footprint and can be freely redistributed.

- 4 Make sure the Oracle client software is properly configured so that you can connect to the Oracle database server at your site.

For information about setting up Oracle configuration files, see your Oracle Net documentation.

- 5 If required by your operating system, make sure the directory containing the Oracle client software is in your system path.

Step 2: Install the database interface

In the InfoMaker Setup program, select the Typical install or select the Custom install and select the Oracle database interfaces you require.

For a list of the Oracle database interfaces available, see “Supported versions for Oracle” on page 105.

Step 3: Verify the connection

Make sure you can connect to the Oracle database server and log in to the database you want to access from outside InfoMaker.

Some possible ways to verify the connection are by running the following Oracle tools:

- **Accessing the database server** Tools such as Oracle TNSPING (or any other ping utility) check whether you can reach the database server from your computer.
- **Accessing the database** Tools such as Oracle SQL*Plus check whether you can log in to the Oracle database you want to access and perform database operations. It is a good idea to specify the same connection parameters you plan to use in your InfoMaker database profile to access the database.

Step 4: Determine whether to use connection or session pooling

Oracle client interface (OCI) pooling for InfoMaker applications is created when you connect to an Oracle server for the first time. The pooling is identified by the server name and character set which are passed in the DBPARM parameters `SQLCA.ServerName` and `NLS_Charset`, respectively. If two Oracle connections are connected to the same Oracle server but use different character sets, the connections must reside in different connection or session pools. All pooling-related DBPARM parameters must be set before the initial database connection from InfoMaker.

Session pooling means that the application creates and maintains a group of stateless sessions to the database. These sessions are passed to thin clients as requested. If no session is available, a new one is created. When the client is done with the session, the client releases it to the pool. With session pooling, the number of sessions in the pool can increase dynamically.

Session pooling does not support external authentication using an OS account. If a Login ID is not specified in a database connection using an existing session pool, the Login ID of the session pooling creator is used for the connection.

CNNPool parameter maintained for backward compatibility

The O90 and O10 database drivers that you can use in InfoMaker to connect to the 9.x and 10.x versions of the Oracle DBMS support connection pooling with the DBPARM parameter `CNNPool`. For backward compatibility purposes, this parameter is also supported by the ORA driver that you use with Oracle 11g. However, if the `Pooling` parameter is used with this driver, the `CNNPool` parameter is ignored.

Deciding on pooling type Table 9-3 describes the circumstances under which you should make your pooling selection.

Table 9-3: Pooling types and when or when not to use them

Choose	When database sessions are
Session pooling	Stateless (reusable by middle tier threads) and the number of back-end server processes can cause database scaling problems.
Connection pooling	Stateful (not reusable by middle tier threads) and the number of back-end server processes can cause database scaling problems. The number of physical connections and back-end server processes is reduced by using connection pooling. Therefore many more database sessions can be utilized for the same back-end server configuration.

Choose	When database sessions are
No pooling	Stateful (not reusable by middle tier threads) and the number of back-end server processes will never be large enough to cause scaling issues for the database. EAServer components and MTS components do not support either type of pooling for Oracle databases.

Setting pooling parameters The database profile dialog box for an Oracle 11g connection includes a Pooling tab that lets you select the pooling parameters listed in Table 9-4.

Table 9-4: Pooling parameters for the ORA driver

Pooling parameter	Description
Pooling Type	You can select Session Pooling, Connection Pooling, or None (default). Sets the Pooling DBPARAM.
Runtime Connection Load Balancing	This check box selected by default. It is ignored when you select Connection Pooling or None for the Pooling Type. Sets the RTConnBalancing DBPARAM.
Homogeneous Session	This check box is not selected by default and is valid for session pooling only. When selected, all sessions in the pool are authenticated with the user name and password in effect when the session pool was created. The user name and password in later connection requests are ignored. Proxy sessions cannot be created in homogeneous session mode. Sets the SessionHomogeneous DBPARAM.
Minimum Number of Sessions	Integer for the minimum number of database connection sessions; value is 1 by default. Sets the CSMin DBPARAM. This value is ignored when the SessionHomogeneous DBPARAM is set to false.
Maximum Number of Sessions	Integer for the maximum number of database connection sessions; value is 100 by default. Sets the CSMax DBPARAM.
Increment	Integer for database connection increments per session; value is 1 by default. Sets the CSIncr DBPARAM. This value is ignored when the SessionHomogeneous DBPARAM is set to false.
Pool Creator	User name used to create the connection or session pool when the pool is not already created. Sets the PoolCreator DBParm to a string for the user name prior to the database connection. If you do not provide a value for the PoolCreator DBParm, the Transaction object's LogID and LogPass properties are used to create the pooling.

Pooling parameter	Description
Password	Password used to create the connection or session pool when the pool is not already created. Sets the PoolPwd DBParm to a string for the password for the pool creator.

Defining the Oracle database interface

To define a connection through an Oracle database interface, you must create a database profile by supplying values for at least the basic connection parameters in the Database Profile Setup dialog box for your Oracle interface. You can then select this profile at any time to connect to your database in the development environment.

For information on how to define a database profile, see “Using database profiles” on page 6.

Specifying the Oracle server connect descriptor

To connect to an Oracle database server that resides on a network, you must specify the proper connect descriptor in the Server box on the Connection tab of the Database Profile Setup dialog box for your Oracle interface. The connect descriptor specifies the connection parameters that Oracle uses to access the database.

For help determining the proper connect descriptor for your environment, see your Oracle documentation or system administrator.

Specifying a connect descriptor

The syntax of the connect descriptor depends on the Oracle client software you are using.

If you are using Net9 or later, the syntax is:

OracleServiceName

If you are using SQL*Net version 2.x, the syntax is:

@ TNS: *OracleServiceName*

Parameter	Description
@	The at (@) sign is required
TNS	The identifier for the Oracle Transparent Network Substrate (TNS) technology

Parameter	Description
:	The colon (:) is required
<i>OracleServiceName</i>	The service name assigned to your server in the Oracle configuration file for your platform

Net9 example To use Net9 client software to connect to the service named ORA9, type the following connect descriptor in the Server box on the Connection tab of the Database Profile Setup dialog box for Oracle9i and later: ORA9.

Using Oracle stored procedures as a data source

This section describes how you can use Oracle stored procedures.

What is an Oracle stored procedure?

Oracle defines a **stored procedure** (or function) as a named PL/SQL program unit that logically groups a set of SQL and other PL/SQL programming language statements together to perform a specific task.

Stored procedures can take parameters and return one or more result sets (also called cursor variables). You create stored procedures in your schema and store them in the data dictionary for use by multiple users.

What you can do with Oracle stored procedures

Ways to use Oracle stored procedures

In your InfoMaker application, you can use an Oracle stored procedure as a data source for reports.

Procedures with a single result set You can use stored procedures that return a single result set in reports, but *not* when using the RPCFUNC keyword to declare a stored procedure as an external function or subroutine.

Using Oracle stored procedures with result sets

Overview of basic steps

The following procedure assumes you are creating the stored procedure in the ISQL view of the Database painter in InfoMaker.

❖ **To use an Oracle stored procedure with a result set:**

- 1 Set up the ISQL view of the Database painter to create the stored procedure.
- 2 Create the stored procedure with a result set as an IN OUT (reference) parameter.
- 3 Create reports that use the stored procedure as a data source.

Setting up the Database painter

When you create a stored procedure in the ISQL view of the Database painter, you must change the default SQL statement terminator character to one that you do not plan to use in your stored procedure syntax.

The default SQL terminator character for the Database painter is a semicolon (;). If you plan to use a semicolon in your Oracle stored procedure syntax, you must change the painter's terminator character to something other than a semicolon to avoid conflicts. A good choice is the backquote (`) character.

❖ **To change the default SQL terminator character in the Database painter:**

- 1 Connect to your Oracle database in InfoMaker as the System user.
For instructions, see "Defining the Oracle database interface" on page 113.
- 2 Open the Database painter.
- 3 Select Design>Options from the menu bar.

The Database Preferences dialog box displays. If necessary, click the General tab to display the General property page.

- 4 Type the character you want (for example, a backquote) in the SQL Terminator Character box.
- 5 Click Apply or OK.

The SQL Terminator Character setting is applied to the current connection and all future connections (until you change it).

Creating the stored procedure

After setting up the Database painter, you can create an Oracle stored procedure that has a result set as an IN OUT (reference) parameter. InfoMaker retrieves the result set to populate a report.

There are many ways to create stored procedures with result sets. The following procedure describes one possible method that you can use.

For information about when you can use stored procedures with single and multiple result sets, see “What you can do with Oracle stored procedures” on page 114.

❖ **To create Oracle stored procedures with result sets:**

- 1 Make sure your Oracle user account has the necessary database access and privileges to access Oracle objects (such as tables and procedures).

Without the appropriate access and privileges, you will be unable to create Oracle stored procedures.

- 2 Assume the following table named `tt` exists in your Oracle database:

a	b	c
1	Newman	sysdate
2	Everett	sysdate

- 3 Create an Oracle package that holds the result set type and stored procedure. The result type must match your table definition.

For example, the following statement creates an Oracle package named `spm` that holds a result set type named `rc1` and a stored procedure named `proc1`. The `tt%ROWTYPE` attribute defines `rc1` to contain all of the columns in table `tt`. The procedure `proc1` takes one parameter, a cursor variable named `rc1` that is an IN OUT parameter of type `rc1`.

```
CREATE OR REPLACE PACKAGE spm
  IS TYPE rc1 IS REF CURSOR
  RETURN tt%ROWTYPE;
  PROCEDURE proc1(rc1 IN OUT rc1);END;`
```

- 4 Create the Oracle stored procedure separately from the package you defined.

The following example shows how to create a stored procedure named `spm_proc 1` that returns a single result set.

The IN OUT specification means that InfoMaker passes the cursor variable (`rc1` or `rc2`) by reference to the Oracle procedure and expects the procedure to open the cursor. After the procedure call, InfoMaker fetches the result set from the cursor and then closes the cursor.

spm_proc1 example for reports The following statements create `spm_proc1` which returns one result set. You can use this procedure as the data source for a report in InfoMaker.

```
CREATE OR REPLACE PROCEDURE spm_proc1 (rc1 IN OUT
    spm.rctl)
AS
BEGIN
    OPEN rc1 FOR SELECT * FROM tt;
END;`
```

Error checking

If necessary, check the Oracle system table `public.user_errors` for a list of errors.

Creating the report

After you create the stored procedure, you can define the report that uses the stored procedure as a data source.

You can use Oracle stored procedures that return a single result set in a report.

The following procedure assumes that your Oracle stored procedure returns only a single result set.

❖ **To create a report using an Oracle stored procedure with a result set:**

1 Select a presentation style on the DataWindow page of the New dialog box and click OK.

2 Select the Stored Procedure icon and click OK.

The Select Stored Procedure wizard page displays, listing the stored procedures available in your database.

3 Select the stored procedure you want to use as a data source, and click Next.

4 Complete the wizard to define the report.

When you preview the report, InfoMaker fetches the result set from the cursor in order to populate the report. If you selected Retrieve on Preview on the Choose Data Source page in the wizard, the result set displays in the Preview view when the DataWindow opens.

Using a large-object output parameter

You can define a large object (LOB) as an output parameter for an Oracle stored procedure or function to retrieve large-object data. There is no limit on the number of LOB output arguments that can be defined for each stored procedure or function.

In Oracle 10g, the maximum size of LOB datatypes has been increased from 4 gigabytes minus 1 to 4 gigabytes minus 1 multiplied by the block size of the database. For a database with a block size of 32K, the maximum size is 128 terabytes.

Using Oracle user-defined types

InfoMaker supports SQL CREATE TYPE and CREATE TABLE statements for Oracle user-defined types (objects) in the ISQL view of the Database painter. It correctly handles SQL SELECT, INSERT, UPDATE, and DELETE statements for user-defined types in the Database and Report painters.

This means that using the Oracle native database interfaces in InfoMaker, you can:

Do this	In
Use Oracle syntax to create user-defined types	Database painter
Use Oracle syntax to create tables with columns that reference user-defined types	Database painter
View columns in Oracle tables that reference user-defined types	Database painter
Manipulate data in Oracle tables that have user-defined types	Database painter Report painter Reports
Export Oracle table syntax containing user-defined types to a log file	Database painter
Invoke methods	Report painter (Compute tab in SQL Toolbox)

Example

Here is a simple example that shows how you might create and use Oracle user-defined types in InfoMaker.

For more information about Oracle user-defined types, see your Oracle documentation.

❖ **To create and use Oracle user-defined types:**

- 1 In the ISQL view of the Database painter, create two Oracle user-defined types: `ball_stats_type` and `player_type`.

Here is the Oracle syntax to create `ball_stats_type`. Notice that the `ball_stats` object of type `ball_stats_type` has a method associated with it called `get_avg`.

```
CREATE OR REPLACE TYPE ball_stats_type AS OBJECT
  (bat_avg NUMBER(4,3), rbi NUMBER(3), MEMBER FUNCTION
  get_avg RETURN NUMBER, PRAGMA RESTRICT_REFERENCES
  (get_avg, WNDS, RNPS, WNPS));
CREATE OR REPLACE TYPE BODY ball_stats_type ASMEMBER
  FUNCTION get_avg RETURN NUMBER ISBEGINRETURN
  SELF.bat_avg;
END;
END;
```

Here is the Oracle SQL syntax to create `player_type`. `Player_type` references the user-defined type `ball_stats_type`. InfoMaker supports such nesting graphically in the Database, Report, and Table painters (see step 3).

```
CREATE TYPE player_type AS OBJECT (player_no
  NUMBER(2), player_name VARCHAR2(30), ball_stats
  ball_stats_type);
```

- 2 In the Database painter, create a table named `lineup` that references these user-defined types.

Here is the Oracle SQL syntax to create the `lineup` table and insert a row. `Lineup` references the `player_type` user-defined type.

```
CREATE TABLE lineup (position NUMBER(2) NOT NULL,
  player player_type);
INSERT INTO lineup VALUES (1, player_type (15,
  'Dustin Pedroia', ball_stats_type (0.317, 50)));
```

- 3 Display the `lineup` table in the Database or Report painter.

InfoMaker uses the following structure->member notation to display the table:

```
lineup
=====
position
player->player_no
player->player_name
```

```
player->ball_stats->bat_avg
player->ball_stats->rbi
```

- 4 To access the `get_avg` method of the object `ball_stats` contained in the object column `player`, use the following structure->member notation when defining a computed column for the report. For example, when working in the Report painter, you could use this notation on the Compute tab in the SQL Toolbox:

```
player->ball_stats->get_avg()
```

ORA driver support for Oracle 11g features

In addition to support for Oracle 11g session pooling and connection pooling, the ORA driver adds support for other 11g features.

Client result cache

The InfoMaker ORA driver supports Oracle Client Cache, however this feature depends on your Oracle Server and Client configuration. You can configure the Oracle Client Cache with an *init.ora* or *sqlnet.ora* file. Cached queries are annotated with “/*+ result_cache */” hints to indicate that results are stored in the query result cache. You enable OCI statement caching from InfoMaker applications with the StatementCache DBPARM parameter.

Application driver name

An OCI application can choose its own name and set it as a diagnostic aid. The AppDriverName DBPARM parameter allows you to set your own client driver name for the InfoMaker ORA interface. The maximum length of the name is 8 characters. You can display the client driver name with the V\$SESSION_CONNECT_INFO or GV\$SESSION_CONNECT_INFO dynamic performance view queries.

Client access through a proxy (Oracle 10.2 feature)

The InfoMaker ORA driver supports the proxy authentication feature that was introduced in Oracle 10.2. With proxy authentication, the end user typically authenticates to a middle tier (such as a firewall), that in turn logs into the database on the user's behalf—as a proxy user. After logging into the database, the proxy user can switch to the end user's identity and perform operations using the authorization accorded to that user.

The ConnectAs DBParm parameter allows you to take advantage of this proxy connection feature. For example, if the user's Transaction object LogID is “Scott” and you set the ConnectAs DBParm parameter to “John”, the OCI client logs in to database as the proxy user (“Scott”), then switches to the end user identity (“John”).

If you are using connection or session pooling, the proxy user name is the connection or session pooling creator (which you can provide in the PoolCreator and PoolPwd DBParm parameters), and the Transaction object's LogID is ignored. No proxy session can be created if pooling is set to HomogeneousSession mode.

Limitation on proxy connection without pooling

When using a proxy connection without pooling, you must set the NLS_Charset DBPARM to "Local" or to another non-Unicode character set. If you do not change the "Unicode" default value for this DBPARM, the connection fails because the Oracle Client Interface does not accept a Unicode name string for its proxy client attribute.

Load balancing

The Oracle Real Application Clusters (RAC) database option allows a single database to be hosted in multiple instances on multiple nodes of the database server. This adds high availability and failover capacity to the database. Availability is improved since, if one node fails, another node can assume its workload. All instances have access to the whole database. The shared disk method of clustering databases used by the RAC option increases scalability because nodes can be added or freed as required.

In RAC environments, session pools can use service metrics received from the RAC load balancing advisory to balance application session requests. The work requests coming into the session pool can then be distributed across the instances of RAC based on current service performance.

Connect time load balancing Balancing of work requests occur at two different times: connect time and runtime. Connect time load balancing occurs when a session is first created by the application. This ensures that sessions that are part of the pool are well distributed across RAC instances, and that sessions on each of the instances get a chance to execute work.

For session pools that support services at one instance only, the first available session in the pool is adequate. When the pool supports services that span multiple instances, there is a need to distribute the work requests across instances so that the instances that are providing better service or have greater capacity get more requests.

Runtime connection load balancing Runtime connection load balancing basically routes work requests to the sessions in a session pool that best serve the work. Runtime connection load balancing is enabled by default when an Oracle 11.1 or higher client is connected to a 10.2 or higher Oracle server using OCI session pooling.

The DBPARM parameter, RTConnBalancing, supports the runtime connection load balancing feature. It is available only when the Pooling parameter is set to Session Pooling, and it can be set before connection only. By default, when you select Session Pooling for the pooling type, the RTConnBalancing value is true.

About this chapter

This chapter describes how to use the DirectConnect™ interface in InfoMaker.

Contents

Topic	Page
Using the DirectConnect interface	123
Supported versions for the DirectConnect interface	125
Supported DirectConnect interface datatypes	126
Basic software components for the DirectConnect interface	127
Preparing to use the database with DirectConnect	128
Defining the DirectConnect interface	131
Creating the extended attribute system tables in DB2 databases	132

Using the DirectConnect interface

The DirectConnect interface uses Sybase's Open Client CT-Library (CT-Lib) API to access a database through Sybase middleware data access products such as the DirectConnect for OS/390 component of Mainframe Connect™ and Open ServerConnect™.

Accessing Unicode data

InfoMaker can connect, save, and retrieve data in both ANSI/DBCS and Unicode databases. When character data or command text is sent to the database, InfoMaker sends a DBCS string if the UTF8 database parameter is set to 0 (the default). If UTF8 is set to 1, InfoMaker sends a UTF-8 string.

The database server must have the UTF-8 character set installed. See the description of the UTF-8 database parameter in the online Help for more information.

A Unicode database is a database whose character set is set to a Unicode format, such as UTF-8, UTF-16, UCS-2, or UCS-4. All data must be in Unicode format, and any data saved to the database must be converted to Unicode data implicitly or explicitly.

A database that uses ANSI (or DBCS) as its character set might use special datatypes to store Unicode data. Columns with these datatypes can store *only* Unicode data. Any data saved into such a column must be converted to Unicode explicitly. This conversion must be handled by the database server or client.

Connecting through the DirectConnect middleware product

Sybase DirectConnect is a data access server that provides a standardized middleware interface between your applications and your enterprise data sources. Data access services to a particular database are defined in a DirectConnect server. Since a DirectConnect server can support multiple access services, you can access multiple databases through a single server.

When you use the DirectConnect interface to connect to a particular database, your connection is routed through the access service for that database. An access service consists of a named set of configuration properties and a specific access service library.

To access DB2 data on an IBM mainframe through a DirectConnect server, you can use the DirectConnect interface to connect through either a DirectConnect for MVS access service or a DirectConnect Transaction Router Service (TRS).

TRS provides fast access to a DB2/MVS database by using remote stored procedures. The DirectConnect interface supports both versions of the TRS library: TRSLU62 and TRSTCP.

The DirectConnect server operates in two modes: SQL transformation and passthrough. The DirectConnect interface for DB2/MVS uses passthrough mode, which allows your InfoMaker application to have direct access to the capabilities of the DB2/MVS data source.

Connecting through the Open ServerConnect middleware product

Sybase's Open ServerConnect supports mainframe applications that retrieve and update data stored on the mainframe that Sybase client applications can execute. Client applications can connect directly to a DB2/MVS database through an Open ServerConnect application residing on the mainframe, eliminating the need for an intermediate gateway like DirectConnect. (This type of connection is also known as a *gateway-less* connection.) In addition, an Open ServerConnect application presents mainframe Remote Procedure Calls (RPCs) as database stored procedures to the client application.

To access DB2 data on an IBM mainframe through Open ServerConnect, you can use the DirectConnect interface to connect through Open ServerConnect for IMS and MVS.

Selecting the type of connection

To select how InfoMaker accesses the database, use the Choose Gateway drop-down list on the Connection tab of the DirectConnect Database Profile Setup dialog box and select one of the following:

- Access Service
- Gatewayless
- TRS

All the DBParm parameters defined for the DirectConnect interface are applicable to all three connections except the following:

- HostReqOwner applies to Access Service and Gatewayless only
- Request, ShowWarnings, and SystemOwner apply to Access Service only
- UseProcSyntax applies to Gatewayless only

See the online help for the complete list of DBParm parameters applicable to the DirectConnect interface.

Supported versions for the DirectConnect interface

The DirectConnect interface uses a DLL named *PBDIR115.DLL* to access a database through either DirectConnect or Open ServerConnect.

Required
DirectConnect
versions

To access a DB2/MVS database through the access service, it is strongly recommended that you use DirectConnect for MVS access service version 11.1.1p4 or later.

To access a DB2/MVS database through TRS, it is strongly recommended that you use DirectConnect TRS version 11.1.1p4 or later.

For information on DirectConnect for MVS and TRS, see your DirectConnect documentation.

Required Open ServerConnect versions

To access a DB2/MVS database through Open ServerConnect, it is strongly recommended that you use Open ServerConnect IMS and MVS version 4.0 or later.

For information on Open ServerConnect for MVS, see your Open ServerConnect documentation.

Supported DirectConnect interface datatypes

The DirectConnect interface supports the InfoMaker datatypes listed in Table 10-1 in reports.

Table 10-1: Supported datatypes for DirectConnect

Char (fewer than 255 characters)	Long VarChar
Char for Bit Data	Real
Date	SmallInt
Decimal	Time
Double Precision	Timestamp (DateTime)
Float	VarChar
Integer	VarChar for Bit Data

Basic software components for the DirectConnect interface

Figure 10-1 shows the basic software components required to access a database using the DirectConnect interface and the DirectConnect middleware data access product.

Figure 10-1: Components of a DirectConnect connection using DirectConnect middleware

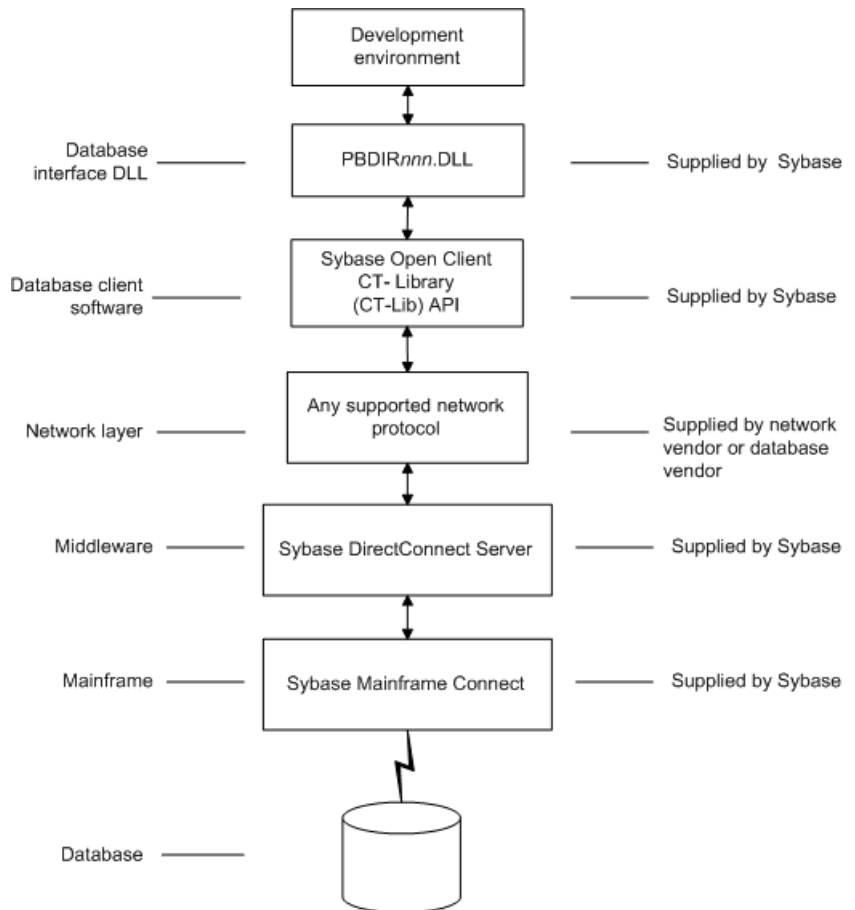
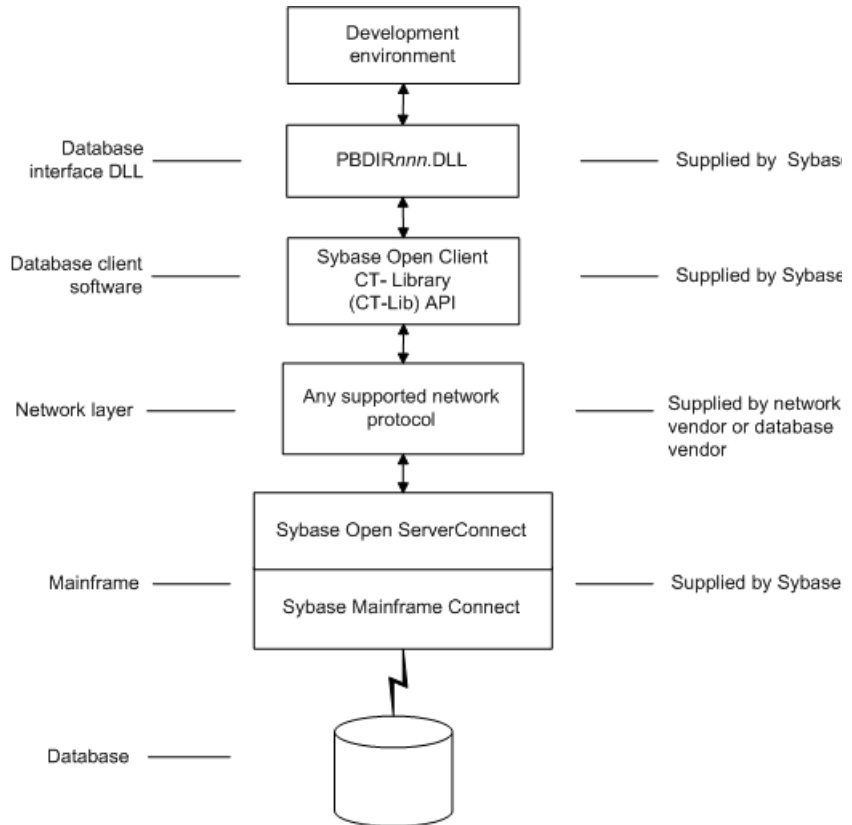

Figure 10-2 shows the basic software components required to access a database using the DirectConnect interface and the Open ServerConnect middleware data access product.

Figure 10-2: Components of a DirectConnect connection using Open ServerConnect middleware



Preparing to use the database with DirectConnect

Before you define the interface and connect to a database through the DirectConnect interface, follow these steps to prepare the database for use:

- 1 Install and configure the Sybase middleware data access products, network, and client software.

Step 1: Install and configure the Sybase middleware product

- 2 Install the DirectConnect interface.
- 3 Verify that you can connect to your middleware product and your database outside InfoMaker.
- 4 Create the extended attribute system tables outside InfoMaker.

You must install and configure the Sybase middleware data access product, network, and client software.

❖ **To install and configure the Sybase middleware data access product, network, and client software:**

- 1 Make sure the appropriate database software is installed and running on its server.

You must obtain the database server software from your database vendor.

For installation instructions, see your database vendor's documentation.

- 2 Make sure the appropriate DirectConnect access service software is installed and running on the DirectConnect server specified in your database profile

or

Make sure the appropriate Open ServerConnect software is installed and running on the mainframe specified in your database profile.

- 3 Make sure the required network software (such as TCP/IP) is installed and running on your computer and is properly configured so you that can connect to the DirectConnect server or mainframe at your site.

You must install the network communication driver that supports the network protocol and operating system platform you are using.

For installation and configuration instructions, see your network or database administrator.

- 4 Install the required Open Client CT-Library (CT-Lib) software on each client computer on which InfoMaker is installed.

You must obtain the Open Client software from Sybase. Make sure the version of Open Client you install supports *both* of the following:

The operating system running on the client computer

The version of InfoMaker that you are running

Open Client required

To use the DirectConnect interface, you must install Open Client.

For information about Open Client, see your Open Client documentation.

- 5 Make sure the Open Client software is properly configured so you can connect to the middleware data access product at your site.

Installing the Open Client software places the *SQL.INI* configuration file in the SQL Server directory on your computer. *SQL.INI* provides information that SQL Server uses to find and connect to the middleware product at your site. You can enter and modify information in *SQL.INI* with the configuration utility or editor that comes with the Open Client software.

For information about editing the *SQL.INI* file, see “Editing the SQL.INI file” on page 131. For more information about setting up *SQL.INI* or any other required configuration file, see your SQL Server documentation.

- 6 If required by your operating system, make sure the directory containing the Open Client software is in your system path.
- 7 Make sure only one copy of each of the following files is installed on your client computer:
 - DirectConnect interface DLL
 - Network communication DLL (such as *NLWNSCK.DLL* for Windows Sockets-compliant TCP/IP)
 - Open Client DLLs (such as *LIBCT.DLL* and *LIBCS.DLL*)

Step 2: Install the interface

In the InfoMaker Setup program, select the Typical install, or select the Custom install and select the Direct Connect Interface (DIR).

Step 3: Verify the connection

Make sure you can connect to your middleware product and your database and log in to the database you want to access from outside InfoMaker.

Some possible ways to verify the connection are by running the following tools:

- **Accessing the database server** Tools such as the Open Client/Open Server Configuration utility (or any Ping utility) check whether you can reach the database server from your computer.
- **Accessing the database** Tools such as ISQL or SQL Advantage (interactive SQL utilities) check whether you can log in to the database and perform database operations. It is a good idea to specify the same connection parameters you plan to use in your InfoMaker database profile to access the database.

Step 4: Create the extended attribute system tables

InfoMaker uses a collection of five system tables to store extended attribute information. When using the DirectConnect interface, you *must* create the extended attribute system tables outside InfoMaker to control the access rights and location of these tables.

Run the *DB2SYSPB.SQL* script outside InfoMaker using the SQL tool of your choice.

For instructions, see “Creating the extended attribute system tables in DB2 databases” on page 132.

Editing the SQL.INI file

Make sure the *SQL.INI* file provides an entry about either the access service being used and the DirectConnect server on which it resides or the Open ServerConnect program being used and the mainframe on which it resides.

For the server object name, you need to provide the exact access service name as it is defined in the access service library configuration file on the DirectConnect server. You must also specify the network communication DLL being used, the TCP/IP address or alias used for the DirectConnect server on which the access service resides, and the port on which the DirectConnect server listens for requests:

```
[access_service_name]
query=network_dll,server_alias,server_port_no
```

InfoMaker users must also specify the access service name in the *SQLCA.ServerName* property of the Transaction object.

Defining the DirectConnect interface

To define a connection through the DirectConnect interface, you must create a database profile by supplying values for at least the basic connection parameters in the Database Profile Setup - DirectConnect dialog box. You can then select this profile anytime to connect to your database in the development environment.

For information on how to define a database profile, see “Using database profiles” on page 6.

Creating the extended attribute system tables in DB2 databases

This section describes how InfoMaker creates the extended attribute system tables in your DB2 database to store extended attribute information. It then explains how to use the *DB2SYSPB.SQL* script to create the extended attribute system tables outside InfoMaker.

You can use the *DB2SYSPB.SQL* script if you are connecting to the IBM DB2 family of databases through any of the following database interfaces:

- ODBC interface
- Sybase DirectConnect interface

Creating the extended attribute system tables

When you create or modify a table in InfoMaker, the information you provide is stored in five system tables in your database. These system tables contain extended attribute information such as the text to use for labels and column headings, validation rules, display formats, and edit styles. (These system tables are different from the system tables provided by your DB2 database.)

By default, the extended attribute system tables are created automatically the first time a user connects to the database using InfoMaker.

When you use the DirectConnect interface

When you use the DirectConnect interface, the extended attribute system tables are *not* created automatically. You must run the *DB2SYSPB.SQL* script to create the system tables as described in “Using the *DB2SYSPB.SQL* script” on page 133.

- ❖ **To ensure that the extended attribute system tables are created with the proper access rights:**
 - Make sure the first person to connect to the database with InfoMaker has sufficient authority to create tables and grant permissions to PUBLIC.

This means that the first person to connect to the database should log in as the database owner, database administrator, system user, system administrator, or system owner, as specified by your DBMS.

Using the DB2SYSPB.SQL script

Why do this If you are a system administrator at a DB2 site, you might prefer to create the extended attribute system tables outside InfoMaker for two reasons:

- The first user to connect to the DB2 database using InfoMaker might not have the proper authority to create tables.
- When InfoMaker creates the extended attribute system tables, it places them in the default tablespace. This might not be appropriate for your needs.

When using the DirectConnect interface

You *must* create the extended attribute system tables outside InfoMaker if you are using the DirectConnect interface. You need to decide which database and tablespace should store the system tables. You might also want to grant update privileges only to specific developers or groups.

What you do To create the extended attribute system tables, you run the *DB2SYSPB.SQL* script outside InfoMaker. This script contains SQL commands that create and initialize the system tables with the table owner and tablespace you specify.

Where to find DB2SYSPB.SQL The *DB2SYSPB.SQL* script is in the *Server* directory on the InfoMaker CD-ROM. This directory contains server-side installation components and is *not installed* with InfoMaker on your computer.

You can access the *DB2SYSPB.SQL* script directly from your computer's CD-ROM drive or you can copy it to your computer.

Use the following procedure *from the database server* to create the extended attribute system tables in a DB2 database outside InfoMaker. This procedure assumes you are accessing the *DB2SYSPB.SQL* script from the product CD in your computer's CD-ROM drive and the drive letter is Z.

❖ **To create the extended attribute system tables in a DB2 database outside InfoMaker:**

- 1 Log in to the database server or gateway as the system administrator.
- 2 Insert the InfoMaker CD-ROM into the computer's CD-ROM drive.

- 3 Use any text editor to modify *Z:\Server\DB2SYSPB.SQL* for your environment. You can do any of the following:

- Change all instances of PBOwner to another name.

Specifying SYSIBM is prohibited

You cannot specify SYSIBM as the table owner. This is prohibited by DB2.

- Change all instances of database.tablespace to the appropriate value.
- Add appropriate SQL statement delimiters for the tool you are using to run the script.
- Remove comments and blank lines if necessary.

PBCatalogOwner

If you changed PBOwner to another name in the *DB2SYSPB.SQL* script, you must specify the new owner name as the value for the PBCatalogOwner DBParm parameter in your database profile. For instructions, see PBCatalogOwner in the online Help.

- 4 Save any changes you made to the *DB2SYSPB.SQL* script.
- 5 Execute the *DB2SYSPB.SQL* script from the database server or gateway using the SQL tool of your choice.

PART 4

Working with Database Connections

This part describes how to establish, manage, and troubleshoot database connections.

Managing Database Connections

About this chapter

After you install the necessary database software and define the database interface, you can connect to the database from InfoMaker. Once you connect to the database, you can work with the tables and views stored in that database.

This chapter describes how to connect to a database in InfoMaker, maintain database profiles, and share database profiles.

Contents

Topic	Page
About database connections	137
Connecting to a database	140
Maintaining database profiles	143
Sharing database profiles	143
Importing and exporting database profiles	147
About the InfoMaker extended attribute system tables	148

Terminology

In this chapter, the term **database** refers to *both* of the following unless otherwise specified:

- A database or DBMS that you access with a standard database interface and appropriate driver
- A database or DBMS that you access with the appropriate native database interface

About database connections

This section gives an overview of when database connections occur in InfoMaker. It also explains why you should use database profiles to manage your database connections.

When database connections occur

Connections in InfoMaker

In the development environment, the setting of the Automatically Connect to Database system option controls whether InfoMaker connects to the database when you open a painter requiring a connection (the default) or automatically when you start InfoMaker.

The Automatically Connect to Database option has no effect in InfoMaker applications at runtime. Like PowerBuilder, InfoMaker connects to your database when you run an application that accesses the database.

❖ **To set the Automatically Connect to Database option in InfoMaker:**

- 1 Select Tools>System Options from the menu bar.

The System Options dialog box displays.

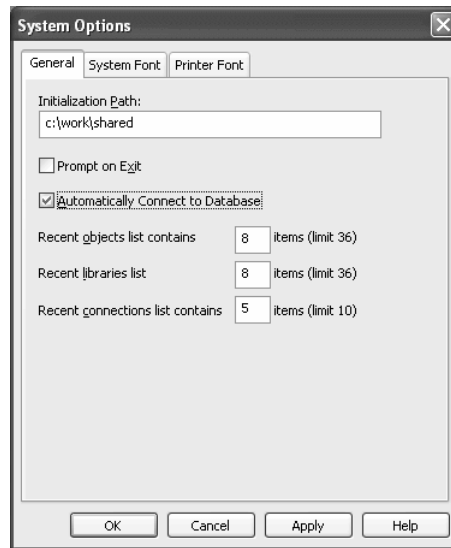

- 2 On the General tab page, select or clear the Automatically Connect to Database check box as follows:

Select the check box The next time you start InfoMaker, it automatically connects to the database at startup and stays connected throughout the session until you exit.

Clear the check box (Default) The next time you start InfoMaker, it connects to the database only when you open one of the following painters requiring a connection: Database, Report, Form, Data Pipeline, or Query. It does *not* connect to the database automatically at startup.

- 3 Click OK or Apply.

InfoMaker saves your AutoConnect setting in the registry.

How InfoMaker determines which database to access

InfoMaker *connects to the database you used last* when you open a painter that accesses the database. InfoMaker determines which database you used last by reading a setting in the registry.

What's in this book

This book describes how to connect to your database when you are working in the InfoMaker development environment.

Using database profiles

What is a database profile?

A **database profile** is a named set of parameters stored in the registry that defines a connection to a particular database in the InfoMaker development environment.

Why use database profiles?

Creating and using database profiles is the easiest way to manage your database connections in InfoMaker because you can:

- Select a database profile to establish or change database connections. You can easily connect to another database anytime during an InfoMaker session. This is particularly useful if you often switch between different database connections.
- Edit a database profile to modify or supply additional connection parameters.
- Delete a database profile if you no longer need to access that data.
- Import and export profiles.

Because database profiles are created when you define your data and are stored in the registry, they have the following benefits:

- They are always available to you.
- Connection parameters supplied in a database profile are saved until you edit or delete the database profile.

Connecting to a database

To establish or change a database connection in InfoMaker, use a database profile. You can select the database profile for the database you want to access in the Database Profiles dialog box. For how to create a database profile, see “Creating a database profile” on page 9.

Using the Database painter to select a database profile

The Database painter is an optional InfoMaker painter. If the Database painter is installed, you can select the database profile for the database you want to access from the Database painter’s Objects view. However, this method uses more system resources than using the Database Profiles dialog box.

Selecting a database profile

You can select a database profile from the Database Profiles dialog box.

❖ To connect to a database using the Database Profiles dialog box:

- 1 Click the Database Profile button in the PowerBar or select Tools>Database Profile from the menu bar.

Database Profile button

If your PowerBar does not include the Database Profile button, use the customize feature to add the button to the PowerBar. Having the Database Profile button on your PowerBar is useful if you frequently switch connections between different databases. For instructions on customizing toolbars, see the *Users Guide*.

The Database Profiles dialog box displays, listing your installed database interfaces.

Where the interface list comes from

When you run the Setup program, it updates the Vendors list in the registry with the interfaces you install. The Database Profiles dialog box displays the same interfaces that appear in the Vendors list.

- 2 Click the plus sign (+) to the left of the interface you are using or double-click the name.

The list expands to display the database profiles defined for your interface.

- 3 Select the name of the database profile you want to access and click Connect or display the pop-up menu for a database profile and select Connect.

InfoMaker connects to the specified database and returns you to the painter workspace.

Database painter
Objects view

You can select a database profile from the Database painter Objects view.

❖ **To connect to a database using the Database painter:**

- 1 Click the Database painter button in the PowerBar.

The Database painter displays. The Objects view lists your installed database interfaces.

Where the interface list comes from

When you run the Setup program, it updates the Vendors list in the registry with the interfaces you install. The Database painter Objects view displays the same interfaces that appear in the Vendors list.

- 2 Click the plus sign (+) to the left of the interface you are using or double-click the name.

The list expands to display the database profiles defined for your interface.

- 3 Select the name of the database profile you want to access and click the Connect button, or display the pop-up menu for a database profile and select Connect.

What happens when you connect

When you connect to a database by selecting its database profile, InfoMaker writes the profile name and its connection parameters to the registry key *HKEY_CURRENT_USER\Software\Sybase\PowerBuilder\11.5\DatabaseProfiles\PowerBuilder*.

Each time you connect to a different database, InfoMaker overwrites the “most-recently used” profile name in the registry with the name for the new database connection.

When you start InfoMaker (with the Automatically Connect to Database system option selected) or open a painter that accesses the database, you are connected to the database you used last. InfoMaker determines which database this is by reading the registry.

The three-letter abbreviation for the database interface followed by the name of the database profile displays in InfoMaker's main title bar. If you are working with a report or form, this visual cue makes it easier to check that you are using the right connection.

For example, if you open the tutorial PBL and connect to the EAS Demo database, the title bar displays “tutor_im.pbl - ODB [EAS Demo DB V115 IM] - InfoMaker.”

Specifying passwords in database profiles

Your password does *not* display when you specify it in the Database Profile Setup dialog box.

However, when InfoMaker stores the values for this profile in the registry, the actual password *does* display, in encrypted form, in the DatabasePassword or LogPassword field.

Suppressing display in the profile registry entry

To suppress password display in the profile registry entry, do the following when you create a database profile.

❖ **To suppress password display in the profile registry entry:**

- 1 Select the Prompt For Database Information check box on the Connection tab in the Database Profile Setup dialog box.

This tells InfoMaker to prompt for any missing information when you select this profile to connect to the database.

- 2 Leave the Password box blank. Instead, specify the password in the dialog box that displays to prompt you for additional information when you connect to the database.

What happens

When you specify the password in response to a prompt instead of in the Database Profile Setup dialog box, the password does not display in the registry entry for this profile.

For example, if you do not supply a password in the Database Profile Setup - Adaptive Server Enterprise dialog box when creating a database profile, the Client Library Login dialog box displays to prompt you for the missing information.

Maintaining database profiles

You can easily edit or delete an existing database profile in InfoMaker.

You can edit a database profile to change one or more of its connection parameters. You can delete a database profile when you no longer need to access its data. You can also change a profile using either the Database Profiles dialog box or the Database painter.

What happens

When you edit or delete a database profile, InfoMaker either updates the database profile entry in the registry or removes it.

Deleting a profile for an ODBC data source

If you delete a database profile that connects to an ODBC data source, InfoMaker does *not* delete the corresponding data source definition from the ODBC initialization file. This lets you re-create the database profile later if necessary without having to redefine the data source.

Sharing database profiles

When you work in InfoMaker, you can share database profiles among users.

Sharing database profiles between Sybase tools

Since the database profiles used by PowerBuilder and InfoMaker are stored in a common registry location, database profiles you create in any of these tools are automatically available for use by the others, if the tools are running on the same computer.

This section describes what you need to know to set up, use, and maintain shared database profiles in InfoMaker.

About shared database profiles

You can share database profiles in the InfoMaker development environment by specifying the location of a file containing the profiles you want to share. You specify this location in the Database Preferences dialog box in the Database painter.

Where to store a shared profile file

To share database profiles among all InfoMaker users at your site, store a profile file on a network file server accessible to all users.

When you share database profiles, InfoMaker displays shared database profiles from the file you specify as well as those from your registry.

Shared database profiles are read-only. You can select a shared profile to connect to a database—but you *cannot* edit, save, or delete profiles that are shared. (You can, however, make changes to a shared profile and save it on your computer, as described in “Making local changes to shared database profiles” on page 146.)

Setting up shared database profiles

You set up shared database profiles in the Database Preferences dialog box.

❖ To set up shared database profiles:

- 1 In the Database painter, select Design>Options from the menu bar to display the Database Preferences dialog box.
- 2 In the Shared Database Profiles box on the General tab page, specify the location of the file containing the database profiles you want to share. Do this in either of the following ways:
 - Type the location (path name) in the Shared Database Profiles box.
 - Click the Browse button to navigate to the file location and display it in the Shared Database Profiles box.

In the following example, *c:\work\share.ini* is the location of the file containing the database profiles to be shared:

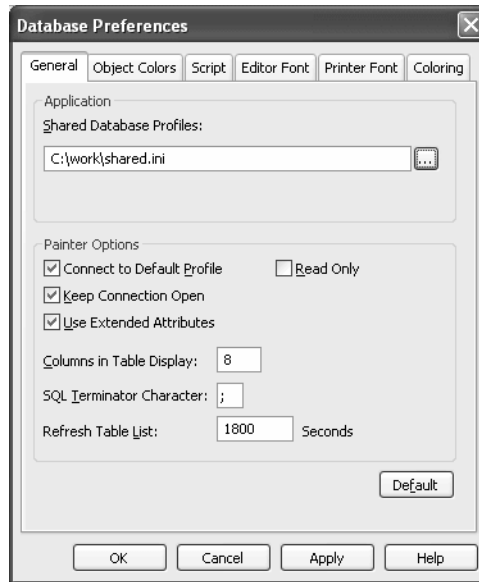

- 3 Click OK.

InfoMaker applies the Shared Database Profiles setting to the current connection and all future connections and saves the setting in the registry.

Using shared database profiles to connect

You select a shared database profile to connect to a database the same way you select a profile stored in your registry. You can select the shared profile in the Database Profiles dialog box or from the File>Connect menu.

Database Profiles dialog box

You can select and connect to a shared database profile in the Database Profiles dialog box.

❖ To select a shared database profile in the Database Profiles dialog box:

- 1 Click the Database Profile button in the PowerBar or select Tools>Database Profile from the menu bar.

The Database Profiles dialog box displays, listing both shared and local profiles. Shared profiles are denoted by a network icon and the word (*Shared*).

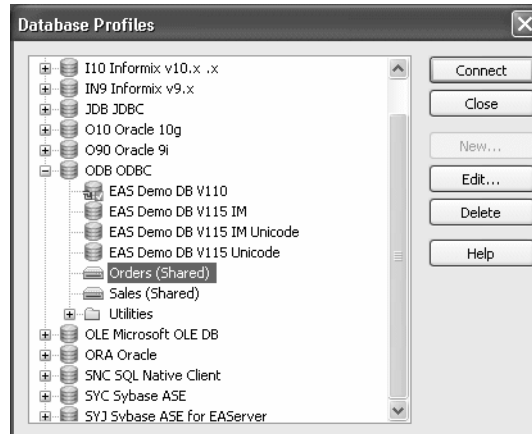

- 2 Select the name of the shared profile you want to access and click Connect.

InfoMaker connects to the selected database and returns you to the painter workspace.

Making local changes to shared database profiles

Because shared database profiles can be accessed by multiple users running InfoMaker, you should not make changes to these profiles. However, if you want to modify and save a copy of a shared database profile *for your own use*, you can edit the profile and save the modified copy in your computer's registry.

❖ **To save changes to a shared database profile in your registry:**

- 1 In the Database Profiles dialog box, select the shared profile you want to edit and click the Edit button.
- 2 In the Database Profile Setup dialog box that displays, edit the profile values as needed and click OK.

A message box displays, asking if you want to save a copy of the modified profile to your computer.

- 3 Click Yes.

InfoMaker saves the modified profile in your computer's registry.

Maintaining shared database profiles

If you maintain the database profiles for InfoMaker at your site, you might need to update shared database profiles from time to time and make these changes available to your users.

Because shared database profiles can be accessed by multiple users running InfoMaker, it is *not* a good idea to make changes to the profiles over a network. Instead, you should make any changes locally and then provide the updated profiles to your users.

❖ **To maintain shared database profiles at your site:**

- 1 Make and save required changes to the shared profiles on your own computer. These changes are saved in your registry.

For instructions, see “Making local changes to shared database profiles” on page 146.

- 2 Export the updated profile entries from your registry to the existing file containing shared profiles.

For instructions, see “Importing and exporting database profiles” on page 147.

- 3 If they have not already done so, have users specify the location of the new profiles file in the Database Preferences property sheet so that they can access the updated shared profiles on their computer.

For instructions, see “Setting up shared database profiles” on page 144.

Importing and exporting database profiles

Each database interface provides an Import Profile(s) and an Export Profile(s) option. You can use the Import option to import a previously defined profile for use with an installed database interface. Conversely, you can use the Export option to export a defined profile for use by another user.

The ability to import and export profiles provides a way to move profiles easily between developers. It also means you no longer have to maintain a shared file to maintain profiles. It is ideal for mobile development when you cannot rely on connecting to a network to share a file.

❖ **To import a profile:**

- 1 Highlight a database interface and select Import Profile(s) from the pop-up menu. (In the Database painter, select Import Profile(s) from the File or pop-up menu.)
- 2 From the Select Profile File dialog box, select the file whose profiles you want to import and click Save.
- 3 Select the profile(s) you want to import from the Import Profile(s) dialog box and click OK.

The profiles are copied into your registry. If a profile with the same name already exists, you are asked if you want to overwrite it.

❖ **To export a profile:**

- 1 Highlight a database interface and select Export Profile(s) from the pop-up menu. (In the Database painter, select Export Profile(s) from the File or pop-up menu.)
- 2 Select the profile(s) you want to export from the Export Profile(s) dialog box and click OK.

The Export Profile(s) dialog box lists all profiles defined in your registry regardless of the database interface for which they were defined. By default, the profiles defined for the selected database interface are marked for export.

- 3 From the Select Profile File dialog box, select a directory and a file in which to save the exported profile(s) and click Save.

The exported profiles can be saved to a new or existing file. If saved to an existing file, the profile(s) are added to the existing profiles. If a profile with the same name already exists, you are asked if you want to overwrite it.

About the InfoMaker extended attribute system tables

InfoMaker uses a collection of five system tables to store extended attribute information (such as display formats, validation rules, and font information) about tables and columns in your database. You can also define extended attributes when you create or modify a table in InfoMaker.

This section tells you how to:

- Make sure the InfoMaker extended attribute system tables are created with the proper access rights when you log in to your database for the first time
- Display and open an InfoMaker extended attribute system table
- Understand the kind of information stored in the InfoMaker extended attribute system tables
- Control extended attribute system table access

Logging in to your database for the first time

By default, InfoMaker creates the extended attribute system tables the first time you connect to a database.

To ensure that InfoMaker creates the extended attribute system tables with the proper access rights to make them available to all users, the first person to connect to the database with InfoMaker must log in with the proper authority.

- ❖ **To ensure proper creation of the InfoMaker extended attribute system tables:**
 - Make sure the first person to connect to the database with InfoMaker has sufficient authority to create tables and grant permissions to PUBLIC.

This means that the first person to connect to the database should log in as the database owner, database administrator, system user, system administrator, or system owner, as specified by your DBMS.

Creating the extended attribute system tables when using the DirectConnect interface

When you are using the DirectConnect interface, the InfoMaker extended attribute system tables are *not* created automatically the first time you connect to a database. You must run the *DB2SYSPB.SQL* script to create the system tables, as described in “Using the *DB2SYSPB.SQL* script” on page 133.

Displaying the InfoMaker extended attribute system tables

InfoMaker updates the extended attribute system tables automatically whenever you change the information for a table or column. The InfoMaker extended attribute system tables are different from the system tables provided by your DBMS.

You can display and open InfoMaker extended attribute system tables in the Database painter just like other tables.

❖ **To display the InfoMaker extended attribute system tables:**

- 1 In the Database painter, highlight Tables in the list of database objects for the active connection and select Show System Tables from the pop-up menu.

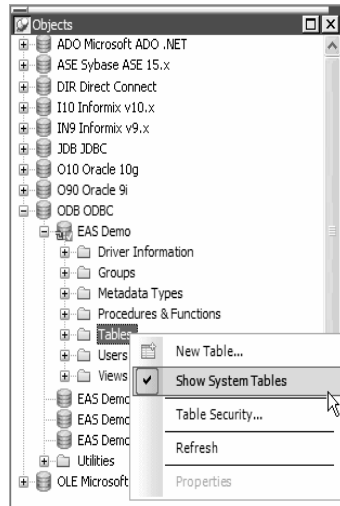

- 2 The InfoMaker extended attribute system tables and DBMS system tables display in the tables list, as follows:
 - **InfoMaker system tables** The five system tables are: pbcaccol, pbcatedt, pbcacfmt, pbcattbl, and pbcacvld.

- **DBMS system tables** The system tables supplied by the DBMS usually have a DBMS-specific prefix (such as *sys* or *dbo*).

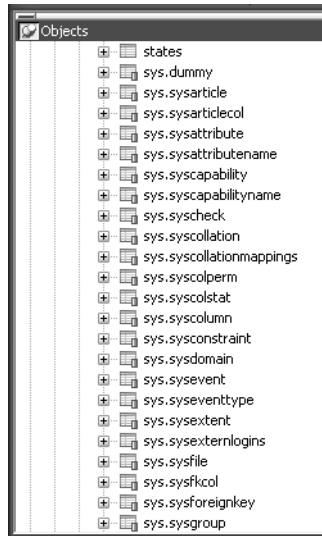

- 3 Display the contents of an InfoMaker system table in the Object Layout, Object Details, and/or Columns views.

For instructions, see the *Users Guide*.

Do not edit the extended attribute system tables

Do not change the values in the InfoMaker extended attribute system tables.

Contents of the extended attribute system tables

InfoMaker stores five types of extended attribute information in the system tables as described in Table 11-1.

Table 11-1: Extended attribute system tables

System table	Information about	Attributes
pbcatcol	Columns	Names, comments, headers, labels, case, initial value, and justification
pbcatedt	Edit styles	Edit style names and definitions
pbcatfmt	Display formats	Display format names and definitions

System table	Information about	Attributes
pbcatbl	Tables	Name, owner, default fonts (for data, headings and labels), and comments
pbcatvld	Validation rules	Validation rule names and definitions

For more about the InfoMaker system tables, see the Appendix in the *Users Guide*.

Prefixes in system table names

For some databases, InfoMaker precedes the name of the system table with a default DBMS-specific prefix. For example, the names of InfoMaker system tables have the prefix DBO in a SQL Server database (such as DBO.pbcatcol), or SYSTEM in an Oracle database (such as SYSTEM.pbcatfmt).

The preceding table gives the base name of each system table without the DBMS-specific prefix.

Controlling system table access

To control access to the InfoMaker system tables at your site, you can specify that InfoMaker not create or update the system tables or that the system tables be accessible only to certain users or groups.

You can control system table access by doing any of the following:

- **Setting Use Extended Attributes** Set the Use Extended Attributes database preference in the Database Preferences dialog box in the Database painter.
- **Setting Read Only** Set the Read Only database preference in the Database Preferences dialog box in the Database painter.
- **Granting permissions on the system tables** Grant explicit permissions on the system tables to users or groups at your site.

Setting Use Extended Attributes or Read Only to control access

❖ **To control system table access by setting Use Extended Attributes or Read Only:**

- 1 Select Design>Options from the menu bar to display the Database Preferences dialog box.

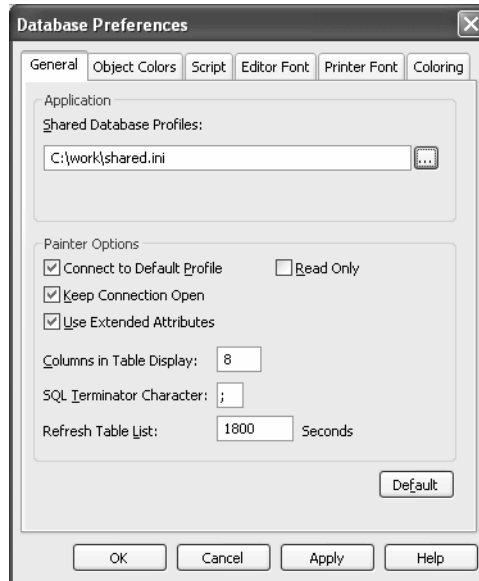

- 2 On the General page, set values for Use Extended Attributes or Read Only as follows:

Preference	What you do	Effect
Use Extended Attributes	Clear the check box	Does not create the InfoMaker system tables if they do not exist. Instead, the painter uses the appropriate default values for extended attributes (such as headers, labels, and text color). If the InfoMaker system tables already exist, InfoMaker does not use them when you create a new report or form.
Read Only	Select the check box	If the InfoMaker system tables already exist, InfoMaker uses them when you create a new report or form, <i>but does not update them</i> . You <i>cannot</i> modify (update) information in the system tables or any other database tables in the Report painter or Form painter when the Read Only check box is selected.

- 3 Click OK.

InfoMaker applies the preference settings to the current connection and all future connections and saves them in the registry.

Granting permissions on system tables to control access

If your DBMS supports SQL GRANT and REVOKE statements, you can control access to the InfoMaker system tables. The default authorization for each repository table is:

```
GRANT SELECT, UPDATE, INSERT, DELETE ON table TO PUBLIC
```

After the system tables are created, you can (for example) control access to them by granting SELECT authority to end users and SELECT, UPDATE, INSERT, and DELETE authority to developers. This technique offers security and flexibility that is enforced by the DBMS itself.

Setting Additional Connection Parameters

About this chapter

To fine-tune your database connection and take advantage of DBMS-specific features that your interface supports, you can set additional connection parameters at any time. These additional connection parameters include:

- Database parameters
- Database preferences

These connection parameters are described in the Database Connectivity section in the online Help.

This chapter describes how to set database parameters and database preferences in InfoMaker.

Contents

Topic	Page
Basic steps for setting connection parameters	155
About the Database Profile Setup dialog box	156
Setting database parameters	157
Setting database preferences	158

Basic steps for setting connection parameters

This section gives basic steps for setting database parameters and database preferences in InfoMaker.

❖ To set database parameters:

- 1 Learn how to set database parameters in the development environment.

See “Setting database parameters” on page 157.

- 2 Determine the database parameters you can set for your database interface.
For a table listing each supported database interface and the database parameters you can use with that interface, see “Database parameters and supported database interfaces” in the online Help.
- 3 Read the description of the database parameter you want to set in the online Help.
- 4 Set the database parameter for your database connection.

❖ **To set database preferences:**

- 1 Learn how to set database preferences in the development environment.
See “Setting database preferences” on page 158.
- 2 Determine the database preferences you can set for your DBMS.
For a table listing each supported database interface and the database preferences you can use with that interface, see “Database parameters and supported database interfaces” in the online Help.
- 3 Read the description of the database preference you want to set in the online Help.
- 4 Set the database preference for your database connection.

About the Database Profile Setup dialog box

The interface-specific Database Profile Setup dialog box makes it easy to set additional connection parameters in the development environment. You can:

- Supply values for connection options supported by your database interface
Each database interface has its own Database Profile Setup dialog box that includes settings only for those connection parameters supported by the interface. Similar parameters are grouped on the same tab page. The Database Profile Setup dialog box for *all* interfaces includes the Connection tab. Depending on the requirements and features of your interface, one or more other tab pages might also display.

- Easily set additional connection parameters in the development environment

You can specify additional connection parameters (database parameters and transaction object properties) with easy-to-use check boxes, drop-down lists, and text boxes. InfoMaker generates the proper syntax automatically when it saves your database profile in the system registry.

Setting database parameters

In InfoMaker, you can set database parameters by editing the Database Profile Setup dialog box for your connection.

Setting database parameters in the development environment

Editing database profiles

To set database parameters for a database connection in the InfoMaker development environment, you must edit the database profile for that connection.

Character limit for strings

Strings containing database parameters that you specify in the Database Profile Setup dialog box for your connection can be up to 999 characters in length.

This limit applies only to database parameters that you set in a database profile in the development environment. Database strings specified in code as properties of the Transaction object are *not* limited to a specified length.

Setting database preferences

How to set

The way you set connection-related database preferences in InfoMaker varies, as summarized in the following table.

Table 12-1: Database preferences and where they can be set

Database preference	Set in development environment by editing
AutoCommit	Database Profile Setup dialog box for your connection
Lock	Database Profile Setup dialog box for your connection
Shared Database Profiles	Database Preferences dialog box
Connect DB at Startup	Database Preferences dialog box
Connect to Default Profile	Database Preferences dialog box
Read Only	Database Preferences dialog box
Keep Connection Open	Database Preferences dialog box
Use Extended Attributes	Database Preferences dialog box
SQL Terminator Character	Database Preferences dialog box

The following sections give the steps for setting database preferences in the development environment.

For more information

For information about using a specific database preference, see its description in the online Help.

Setting database preferences in the development environment

There are two ways to set database preferences in the InfoMaker development environment on *all* supported development platforms, depending on the preference you want to set:

- Set AutoCommit and Lock (Isolation Level) in the Database Profile Setup dialog box for your connection
- Set all other database preferences in the Database Preferences dialog box in the Database painter

Setting AutoCommit and Lock in the database profile

The AutoCommit and Lock (Isolation Level) preferences are properties of the default Transaction object, SQLCA. For AutoCommit and Lock to take effect in the InfoMaker development environment, you must specify them *before* you connect to a database. Changes to these preferences after the connection occurs have no effect on the current connection.

To set AutoCommit and Lock before InfoMaker connects to your database, you specify their values in the Database Profile Setup dialog box for your connection.

❖ **To set AutoCommit and Lock (Isolation Level) in a database profile:**

- 1 Display the Database Profiles dialog box.
- 2 Click the plus sign (+) to the left of the interface you are using or double-click the interface name.

The list expands to display the database profiles defined for your interface.

- 3 Select the name of the profile you want and click Edit.

The Database Profile Setup dialog box for the selected profile displays.

- 4 On the Connection tab page, supply values for one or both of the following:
 - **Isolation Level** If your database supports the use of locking and isolation levels, select the isolation level you want to use for this connection from the Isolation Level drop-down list. (The Isolation Level drop-down list contains valid lock values for your interface.)
 - **AutoCommit Mode** The setting of AutoCommit controls whether InfoMaker issues SQL statements outside (True) or inside (False) the scope of a transaction. *If your database supports it*, select the AutoCommit Mode check box to set AutoCommit to True or clear the AutoCommit Mode check box (the default) to set AutoCommit to False.

For example, in addition to values for basic connection parameters (Server, Login ID, Password, and Database), the Connection tab page for the following Sybase Adaptive Server Enterprise profile named Sales shows nondefault settings for Isolation Level and AutoCommit Mode.

- 5 Click OK to close the Database Profile Setup dialog box.

InfoMaker saves your settings in the database profile entry in the registry.

Setting preferences in the Database Preferences dialog box

To set the following connection-related database preferences, complete the Database Preferences dialog box in the InfoMaker Database painter:

- Shared Database Profiles
- Connect to Default Profile
- Read Only
- Keep Connection Open
- Use Extended Attributes
- SQL Terminator Character

Other database preferences

The Database Preferences dialog box also lets you set other database preferences that affect the behavior of the Database painter itself. For information about the other preferences you can set in the Database Preferences dialog box, see the *Users Guide*.

❖ To set connection-related preferences in the Database Preferences dialog box:

- 1 Open the Database painter.
- 2 Select Design>Options from the menu bar.

The Database Preferences dialog box displays. If necessary, click the General tab to display the General property page.

- 3 Specify values for one or more of the connection-related database preferences in the following table.

Table 12-2: Connection-related database preferences

Preference	Description	For details, see
Shared Database Profiles	Specifies the pathname of the file containing the database profiles you want to share. You can type the pathname or click Browse to display it.	“Sharing database profiles” on page 143
Connect to Default Profile at Startup	Specifies when InfoMaker connects to the database. Select or clear the check box as follows: <ul style="list-style-type: none"> • Select the check box The next time you start InfoMaker, it automatically connects to the database at startup and stays connected throughout the session until you exit. • Clear the check box (Default) The next time you start InfoMaker, it connects to the database only when you open a painter requiring a connection. 	Connect DB at Startup in the online Help
Connect to Default Profile	Controls whether the Database painter establishes a connection to a database using a default profile when the painter is invoked. If not selected, the Database painter opens without establishing a connection to a database.	Connect to Default Profile in online Help
Read Only	Specifies whether InfoMaker should update the extended attribute system tables and any other tables in your database. Select or clear the Read Only check box as follows: <ul style="list-style-type: none"> • Select the check box Does not update the extended attribute system tables or any other tables in your database. You <i>cannot</i> modify (update) information in the extended attribute system tables or any other database tables from the Report and Form painters when the Read Only check box is selected. • Clear the check box (Default) Updates the extended attribute system tables and any other tables in your database. 	Read Only in the online Help
Keep Connection Open	When you connect to a database in InfoMaker without using a database profile, specifies when InfoMaker closes the connection. Select or clear the Keep Connection Open check box as follows: <ul style="list-style-type: none"> • Select the check box (Default) Stays connected to the database during your session and closes the connection when you exit • Clear the check box Opens the connection only when a painter requests it and closes the connection when you close a painter or finish compiling a script <hr/> PowerBuilder only Keep Connection Open has no effect in InfoMaker. <hr/>	Keep Connection Open in the online Help

Preference	Description	For details, see
Use Extended Attributes	<p>Specifies whether InfoMaker should create and use the extended attribute system tables. Select or clear the Use Extended Attributes check box as follows:</p> <ul style="list-style-type: none"> • Select the check box (Default) Creates and uses the extended attribute system tables • Clear the check box Does <i>not</i> create the extended attribute system tables 	Use Extended Attributes in the online Help
Columns in Table Display	Specify the number of table columns to be displayed when InfoMaker displays a table graphically. The default is eight.	
SQL Terminator Character	<p>Specifies the SQL statement terminator character used in the ISQL view in the Database painter in InfoMaker.</p> <p>The default terminator character is a semicolon (;). If you are creating stored procedures and triggers in the ISQL view of the database painter, change the terminator to a character that you do not expect to use in the stored procedure or trigger for your DBMS. A good choice is the backquote (`) character.</p>	SQL Terminator Character in the online Help
Refresh Table List	Specify how frequently you want the table list to be refreshed from the database. The default is 30 minutes.	

4 Do one of the following:

- Click Apply to apply the preference settings to the current connection without closing the Database Preferences dialog box.
- Click OK to apply the preference settings to the current connection and close the Database Preferences dialog box.

InfoMaker saves your preference settings in the database section of *IM.INI*.

Troubleshooting Your Connection

About this chapter

This chapter describes how to troubleshoot your database connection in InfoMaker by using the following tools:

- Database Trace
- ODBC Driver Manager Trace
- JDBC Driver Manager Trace

Contents

Topic	Page
Overview of troubleshooting tools	163
Using the Database Trace tool	164
Using the ODBC Driver Manager Trace tool	173
Using the JDBC Driver Manager Trace tool	177

Overview of troubleshooting tools

When you use InfoMaker, there are several tools available to trace your database connection in order to troubleshoot problems.

Table 13-1: Database trace tools

Use this tool	To trace a connection to
Database Trace	Any database that InfoMaker accesses through one of the database interfaces
ODBC Driver Manager Trace	An ODBC data source only
JDBC Driver Manager Trace	A JDBC database only

Using the Database Trace tool

This section describes how to use the Database Trace tool.

About the Database Trace tool

The Database Trace tool records the internal commands that InfoMaker executes while accessing a database. You can trace a database connection in the development environment.

InfoMaker writes the output of Database Trace to a log file named *DBTRACE.LOG* (by default) or to a nondefault log file that you specify. When you enable database tracing for the first time, InfoMaker creates the log file on your computer. Tracing continues until you disconnect from the database.

Using the Database Trace tool with one connection

You can use the Database Trace tool for only one DBMS at a time and for one database connection at a time.

For example, if your application connects to both an ODBC data source and an Adaptive Server Enterprise database, you can trace either the ODBC connection or the Adaptive Server Enterprise connection, but not both connections at the same time.

How you can use the Database Trace tool

You can use information from the Database Trace tool to understand what InfoMaker is doing *internally* when you work with your database. Examining the information in the log file can help you:

- Understand how InfoMaker interacts with your database
- Identify and resolve problems with your database connection
- Provide useful information to Technical Support if you call them for help with your database connection

If you are familiar with InfoMaker and your DBMS, you can use the information in the log to help troubleshoot connection problems on your own. If you are less experienced or need help, run the Database Trace tool *before* you call Technical Support. You can then report or send the results of the trace to the Technical Support representative who takes your call.

Contents of the Database Trace log

Default contents of the trace file

By default, the Database Trace tool records the following information in the log file when you trace a database connection:

- Parameters used to connect to the database
- Time to perform each database operation (in microseconds)
- The internal commands executed to retrieve and display table and column information from your database. Examples include:
 - Preparing and executing SQL statements such as SELECT, INSERT, UPDATE, and DELETE
 - Getting column descriptions
 - Fetching table rows
 - Binding user-supplied values to columns (if your database supports bind variables)
 - Committing and rolling back database changes
- Disconnecting from the database
- Shutting down the database interface

You can opt to include the names of DBI commands and the time elapsed from the last database connection to the completion of processing for each log entry. You can exclude binding and timing information as well as the data from all fetch requests.

Database Trace dialog box selections

The Database Trace dialog box lets you select the following items for inclusion in or exclusion from a database trace file:

- **Bind variables** Metadata about the result set columns obtained from the database
- **Fetch buffers** Data values returned from each fetch request
- **DBI names** Database interface commands that are processed
- **Time to implement request** Time required to process DBI commands; the interval is measured in thousandths of milliseconds (microseconds)
- **Cumulative time** Cumulative total of timings since the database connection began; the timing measurement is in thousandths of milliseconds

Registry settings for DBTrace

The selections made in the Database Trace dialog box are saved to the registry. Windows registry settings for the database trace utility configuration are stored under the *HKEY_CURRENT_USER\Software\Sybase\InfoMaker\11.5\DBTrace* key. Registry strings under this key are: ShowBindings, FetchBuffers, ShowDBINames, Timing, SumTiming, LogFileName, and ShowDialog. Except for the LogFileName string to which you can assign a full file name for the trace output file, all strings can be set to either 0 or 1.

The ShowDialog registry string can be set to prevent display of the Database Trace dialog box when a database connection is made with tracing enabled. This is the only one of the trace registry strings that you cannot change from the Database Trace dialog box. You must set ShowDialog to 0 in the registry to keep the configuration dialog box from displaying.

INI file settings for DBTrace

If you do not have access to the registry, you can use *IM.INI* to store trace file settings. Add a [DbTrace] section to the INI file with at least one of the following values set, then restart InfoMaker:

```
[DbTrace]
ShowDBINames=0
FetchBuffers=1
ShowBindings=1
SumTiming=1
Timing=1
ShowDialog=1
LogFileName=dbtrace.log
```

The keywords are the same as in the registry and have the same meaning. When you connect to the database again, the initial settings are taken from the INI file, and when you modify them, the changes are written to the INI file.

If the file name for LogFileName does not include an absolute path, the log file is written to the following path, where *<username>* is your login ID: *Documents and Settings\<username>\Application Data\InfoMaker11.5*. If there are no DbTrace settings in the INI file, the registry settings are used.

Error messages

If the database trace utility cannot open the trace output file with write access, an error message lets you know that the specified trace file could not be created or opened. If the trace utility driver cannot be loaded successfully, a message box informs you that the selected Trace DBMS is not supported in your current installation.

Format of the Database Trace log

The specific content of the Database Trace log file depends on the database you are accessing and the operations you are performing. However, the log uses the following basic format to display output:

```
COMMAND: (time)
      {additional_information}
```

Parameter	Description
<i>COMMAND</i>	The internal command that InfoMaker executes to perform the database operation.
<i>time</i>	The number of microseconds it takes InfoMaker to perform the database operation. The precision used depends on your operating system's timing mechanism.
<i>additional_information</i>	(Optional) Additional information about the command. The information provided depends on the database operation.

Example

The following portion of the log file shows the commands InfoMaker executes to fetch two rows from a SQL Anywhere database table:

```
FETCH NEXT: (0.479 MS)
      COLUMN=400 COLUMN=Marketing COLUMN=Evans
FETCH NEXT: (0.001 MS)
      COLUMN=500 COLUMN=Shipping COLUMN=Martinez
```

If you opt to include DBI Names and Sum Time information in the trace log file, the log for the same two rows might look like this:

```
FETCH NEXT: (DBI_FETCHNEXT) (1.459 MS / 3858.556 MS)
      COLUMN=400 COLUMN=Marketing COLUMN=Evans
FETCH NEXT: (DBI_FETCHNEXT) (0.001 MS / 3858.557 MS)
      COLUMN=500 COLUMN=Shipping COLUMN=Martinez
```

For a more complete example of Database Trace output, see “Sample Database Trace output” on page 171.

Starting the Database Trace tool

By default, the Database Trace tool is turned off in InfoMaker. You can start it to trace your database connection.

❖ **To start the Database Trace tool:**

- 1 Open the Database Profile Setup dialog box for the connection you want to trace.
- 2 On the Connection tab, select the Generate Trace check box and click OK or Apply. (The Generate Trace check box is located on the System tab in the OLE DB Database Profile Setup dialog box.)

The Database Profiles dialog box displays with the name of the edited profile highlighted.

For example, here is the relevant portion of a database profile entry for Adaptive Server 12.5 Test. The setting that starts Database Trace is DBMS:

```
[Default]      [value not set]
AutoCommit    "FALSE"
Database      "qadata"
DatabasePassword "00"
DBMS          "TRACE SYC Adaptive Server Enterprise"
DbParm        "Release='12.5'"
Lock          ""
LogId         "qalogin"
LogPassword   "00171717171717"
Prompt        "FALSE"
ServerName    "Host125"
UserID        ""
```

- 3 Click Connect in the Database Profiles dialog box to connect to the database.

The Database Trace dialog box displays, indicating that database tracing is enabled. You can enter the file location where InfoMaker writes the trace output. By default, InfoMaker writes Database Trace output to a log file named *DBTRACE.LOG*. You can change the log file name and location in the Database Trace dialog box.

The Database Trace dialog box also lets you select the level of trace information that you want in the database trace file.

- 4 Select the types of items you want to include in the trace file and click OK. InfoMaker connects to the database and starts tracing the connection.

Stopping the Database Trace tool

Once you start tracing a particular database connection, InfoMaker continues sending trace output to the log until you do one of the following:

- Reconnect to the same database with tracing stopped
 - Connect to another database for which you have not enabled tracing
- ❖ **To stop the Database Trace tool:**
- 1 In the Database Profile Setup dialog box for the database you are tracing, clear the Generate Trace check box on the Connection tab.
 - 2 Click OK in the Database Profile Setup dialog box.

The Database Profiles dialog box displays with the name of the edited profile highlighted.
 - 3 Right-click on the connected database and select Re-connect from the drop-down menu in the Database Profiles dialog box.

InfoMaker connects to the database and stops tracing the connection.

Using the Database Trace log

InfoMaker writes the output of the Database Trace tool to a file named *DBTRACE.LOG* (by default) or to a nondefault log file that you specify. To use the trace log, you can do the following anytime:

- View the Database Trace log with any text editor
- Annotate the Database Trace log with your own comments
- Delete the Database Trace log or clear its contents when it becomes too large

Viewing the Database Trace log

You can display the contents of the log file anytime during an InfoMaker session.

❖ **To view the contents of the log file:**

- Open the log file in one of the following ways:
 - Use the File Editor in InfoMaker. (For instructions, see the *Users Guide*.)
 - Use any text editor outside InfoMaker.

Leaving the log file open

If you leave the log file open as you work in InfoMaker, the Database Trace tool *does not update* the log.

Annotating the Database Trace log

When you use the Database Trace log as a troubleshooting tool, it might be helpful to add your own comments or notes to the file. For example, you can specify the date and time of a particular connection, the versions of database server and client software you used, or any other useful information.

❖ **To annotate the log file:**

- 1 Open the *DBTRACE.LOG* file in one of the following ways:
 - Use the File Editor in InfoMaker. (For instructions, see the *Users Guide*.)
 - Use any text editor outside InfoMaker.
- 2 Edit the log file with your comments.
- 3 Save your changes to the log file.

Deleting or clearing the Database Trace log

Each time you connect to a database with tracing enabled, InfoMaker appends the trace output of your connection to the existing log. As a result, the log file can become very large over time, especially if you frequently enable tracing when connected to a database.

❖ **To keep the size of the log file manageable:**

- Do either of the following periodically:

- Open the log file, clear its contents, and save the empty file.

Provided that you use the default *DBTRACE.LOG* or the same nondefault file the next time you connect to a database with tracing enabled, InfoMaker will write to this empty file.

- Delete the log file.

InfoMaker will automatically create a new log file the next time you connect to a database with tracing enabled.

Sample Database Trace output

This section gives an example of Database Trace output that you might see in the log file and briefly explains each portion of the output.

The example traces a connection with Sum Timing enabled. The output was generated while running an InfoMaker application that displays information about authors in a publications database. The `SELECT` statement shown retrieves information from the Author table.

The precision (for example, microseconds) used when Database Trace records internal commands depends on your operating system's timing mechanism. Therefore, the timing precision in your Database Trace log might vary from this example.

Connect to database

```
CONNECT TO TRACE SYNC Adaptive Server Enterprise:
DATABASE=pubs2
LOGID=bob
SERVER=HOST12
DPPARM=Release='12.5.2',StaticBind=0
```

Prepare `SELECT` statement

```
PREPARE:
SELECT authors.au_id, authors.au_lname, authors.state
FROM authors
WHERE ( authors.state not in ( 'CA' ) )
ORDER BY authors.au_lname ASC (3.386 MS / 20.349 MS)
```

Get column descriptions DESCRIBE: (0.021 MS / 20.370 MS)
name=au_id, len=12, type=CHAR, pbt=1, dbt=1, ct=0, prec=0, scale=0
name=au_lname, len=41, type=CHAR, pbt=1, dbt=1, ct=0, prec=0, scale=0
name=state, len=3, type=CHAR, pbt=1, dbt=1, ct=0, prec=0, scale=0

Bind memory buffers to columns BIND SELECT OUTPUT BUFFER (DataWindow):
(0.007 MS / 20.377 MS)
name=au_id, len=12, type=CHAR, pbt=1, dbt=1, ct=0, prec=0, scale=0
name=au_lname, len=41, type=CHAR, pbt=1, dbt=1, ct=0, prec=0, scale=0
name=state, len=3, type=CHAR, pbt=1, dbt=1, ct=0, prec=0, scale=0

Execute SELECT statement EXECUTE: (0.001 MS / 20.378 MS)

Fetch rows from result set FETCH NEXT: (0.028 MS / 20.406 MS)
au_id=648-92-1872 au_lname=Blotchet-Hall state=OR
FETCH NEXT: (0.012 MS / 20.418 MS)
au_id=722-51-5454 au_lname=DeFrance state=IN
...
FETCH NEXT: (0.010 MS / 20.478 MS)
au_id=341-22-1782 au_lname=Smith state=KS
FETCH NEXT: (0.025 MS / 20.503 MS)
*** DBI_FETCHEND *** (rc 100)

Update and commit database changes PREPARE:
UPDATE authors SET state = 'NM'
WHERE au_id = '648-92-1872' AND au_lname = 'Blotchet-Halls' AND state = 'OR' (3.284 MS / 23.787 MS)
EXECUTE: (0.001 MS / 23.788 MS)
GET AFFECTED ROWS: (0.001 MS / 23.789 MS)
^ 1 Rows Affected
COMMIT: (1.259 MS / 25.048 MS)

Disconnect from database DISCONNECT: (0.764 MS / 25.812 MS)

Shut down database interface SHUTDOWN DATABASE INTERFACE: (0.001 MS / 25.813 MS)

Using the ODBC Driver Manager Trace tool

This section describes how to use the ODBC Driver Manager Trace tool.

About ODBC Driver Manager Trace

You can use the ODBC Driver Manager Trace tool to trace a connection to any ODBC data source that you access in InfoMaker through the ODBC interface.

Unlike the Database Trace tool, the ODBC Driver Manager Trace tool *cannot* trace connections through one of the native database interfaces.

What this tool does	ODBC Driver Manager Trace records information about ODBC API calls (such as <code>SQLDriverConnect</code> , <code>SQLGetInfo</code> , and <code>SQLFetch</code>) made by InfoMaker while connected to an ODBC data source. It writes this information to a default log file named <code>SQL.LOG</code> or to a log file that you specify.
What both tools do	The information from ODBC Driver Manager Trace, like Database Trace, can help you: <ul style="list-style-type: none"> • Understand what InfoMaker is doing <i>internally</i> while connected to an ODBC data source • Identify and resolve problems with your ODBC connection • Provide useful information to Technical Support if you call them for help with your database connection
When to use this tool	Use ODBC Driver Manager Trace <i>instead</i> of the Database Trace tool if you want more detailed information about the ODBC API calls made by InfoMaker.

Performance considerations

Turning on ODBC Driver Manager Trace can slow your performance while working in InfoMaker. Therefore, use ODBC Driver Manager Trace for debugging purposes only and keep it turned off when you are not debugging.

SQL.LOG file	InfoMaker writes ODBC Driver Manager Trace output to a default log file named <code>SQL.LOG</code> or to a log file that you specify. The default location of <code>SQL.LOG</code> is in your root directory.
--------------	---

Starting ODBC Driver Manager Trace

To start ODBC Driver Manager Trace in order to trace your ODBC connection, you must edit your database profile.

Starting ODBC Driver Manager Trace

To start ODBC Driver Manager Trace, edit the database profile for the connection you want to trace, as described in the following procedure.

❖ **To start ODBC Driver Manager Trace:**

- 1 Open the Database Profile Setup-ODBC dialog box for the ODBC connection you want to trace.
- 2 On the Options tab, select the Trace ODBC API Calls check box.
- 3 (Optional) To specify a log file where you want InfoMaker to write the output of ODBC Driver Manager Trace, type the path name in the Trace File box

or

(Optional) Click Browse to display the pathname of an existing log file in the Trace File box.

By default, if the Trace ODBC API Calls check box is selected and no trace file is specified, InfoMaker sends ODBC Driver Manager Trace output to the default *SQL.LOG* file.

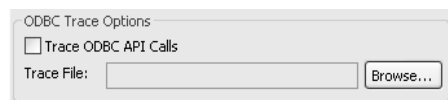

- 4 Click OK or Apply

or

Right-click on the connected database and select Re-connect from the drop-down menu in the Database Profiles dialog box.

The Database Profiles dialog box displays with the name of the edited profile highlighted.

InfoMaker saves your settings in the database profile entry in the registry in the *HKEY_CURRENT_USER\Software\Sybase\11.5\DatabaseProfiles* key.

For example, here is the relevant portion of a database profile entry for an ODBC data source named Employee. The settings that start ODBC Driver Manager Trace (corresponding to the ConnectOption DBParm parameter) are emphasized.

```
DBMS      "ODBC"
...
DbParm    "ConnectString='DSN=Employee;UID=dba;
PWD=00c61737', ConnectOption='SQL_OPT_TRACE,SQL_OPT_
TRACE_ON;SQL_OPT_TRACEFILE,C:\Temp\odbctrce.log'"
```

- 5 Click Connect in the Database Profiles dialog box to connect to the database

or

Right-click on the connected database and select Re-connect from the drop-down menu in the Database Profiles dialog box.

InfoMaker connects to the database, starts tracing the ODBC connection, and writes output to the log file you specified.

Stopping ODBC Driver Manager Trace

Once you start tracing an ODBC connection with ODBC Driver Manager Trace, InfoMaker continues sending trace output to the log file until you stop tracing. After you stop tracing as described in the following sections, you must reconnect to have the changes take effect.

Stopping ODBC Driver Manager Trace

❖ To stop ODBC Driver Manager Trace:

- 1 Open the Database Profile Setup - ODBC dialog box for the connection you are tracing.

For instructions, see “Starting ODBC Driver Manager Trace” on page 174.

- 2 On the Options tab, clear the Trace ODBC API Calls check box.

If you supplied the pathname of a log file in the Trace File box, you can leave it specified in case you want to restart tracing later.

- 3 Click OK in the Database Profile Setup - ODBC dialog box.

The Database Profiles dialog box displays, with the name of the edited profile highlighted.

- 4 Click Connect in the Database Profiles dialog box or right-click on the connected database and select Re-connect from the drop-down menu in the Database Profiles dialog box.

InfoMaker connects to the database and stops tracing the connection.

Viewing the ODBC Driver Manager Trace log

You can display the contents of the ODBC Driver Manager Trace log file anytime during an InfoMaker session.

Location of SQL.LOG

For information about where to find the default SQL.LOG file, see “About ODBC Driver Manager Trace” on page 173.

❖ To view the contents of the log file:

- Open SQL.LOG or the log file you specified in one of the following ways:
 - Use the File Editor in InfoMaker. (For instructions, see the *Users Guide*.)
 - Use any text editor outside InfoMaker.

Leaving the log file open

If you leave the log file open as you work in InfoMaker, ODBC Driver Manager Trace *does not update it*.

Sample ODBC Driver Manager Trace output

This section shows a partial example of output from ODBC Driver Manager Trace to give you an idea of the information it provides. The example is part of the trace on an ODBC connection to the EAS Demo DB.

For more about a particular ODBC API call, see your ODBC documentation.

```
IM115 e58-a58EXIT SQLSetConnectAttrW with return
code 0 (SQL_SUCCESS)
      SQLHDBC 021E1590
      SQLINTEGER 104 <SQL_ATTR_TRACE>
      SQLPOINTER 0x00000001 (BADMEM)
      SQLINTEGER 0
```

```

IM115 e58-a58ENTER SQLSetConnectAttrW
      SQLHDBC 021E1590
      SQLINTEGER 105 <SQL_ATTR_TRACEFILE>
      SQLPOINTER 0x03A67602 (NYI)
      SQLINTEGER -3

```

Using the JDBC Driver Manager Trace tool

This section describes how to use the JDBC Driver Manager Trace tool.

About JDBC Driver Manager Trace

You can use the JDBC Driver Manager Trace tool to trace a connection to any database that you access in InfoMaker through the JDBC interface.

Unlike the Database Trace tool, the JDBC Driver Manager Trace tool *cannot* trace connections through one of the native database interfaces.

What this tool does	JDBC Driver Manager Trace logs errors and informational messages originating from the Driver object currently loaded (such as Sybase's jConnect JDBC driver) when InfoMaker connects to a database through the JDBC interface. It writes this information to a default log file named <i>JDBC.LOG</i> or to a log file that you specify. The amount of trace output varies depending on the JDBC driver being used.
What both tools do	The information from JDBC Driver Manager Trace, like Database Trace, can help you: <ul style="list-style-type: none"> • Understand what InfoMaker is doing <i>internally</i> while connected to a database through the JDBC interface • Identify and resolve problems with your JDBC connection • Provide useful information to Technical Support if you call them for help with your database connection
When to use this tool	Use JDBC Driver Manager Trace <i>instead</i> of the Database Trace tool if you want more detailed information about the JDBC driver.

Performance considerations

Turning on JDBC Driver Manager Trace can slow your performance while working in InfoMaker. Therefore, use JDBC Driver Manager Trace for debugging purposes only and keep it turned off when you are not debugging.

JDBC.LOG file

InfoMaker writes JDBC Driver Manager Trace output to a default log file named *JDBC.LOG* or to a log file that you specify. The default location of *JDBC.LOG* is a temp directory.

Starting JDBC Driver Manager Trace

To start JDBC Driver Manager Trace in order to trace your JDBC connection, you must edit your database profile.

Starting JDBC Driver Manager Trace

To start JDBC Driver Manager Trace, edit the database profile for the connection you want to trace, as described in the following procedure.

❖ **To start JDBC Driver Manager Trace:**

- 1 Open the Database Profile Setup - JDBC dialog box for the JDB connection you want to trace.
- 2 On the Options tab, select the Trace JDBC Calls check box.
- 3 (Optional) To specify a log file where you want InfoMaker to write the output of JDBC Driver Manager Trace, type the path name in the Trace File box, or click Browse to display the path name of an existing log file in the Trace File box.

By default, if the Trace JDBC Calls check box is selected and no alternative trace file is specified, InfoMaker sends JDBC Driver Manager Trace output to the default *JDBC.LOG* file.

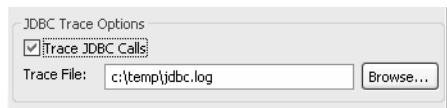

- 4 Click OK or Apply.

The Database Profiles dialog box displays with the name of the edited profile highlighted. InfoMaker saves your settings in the database profile entry in the registry.

For example, here are the DBMS and DBParm string values of a database profile entry for a database named Employee. The settings that start JDBC Driver Manager Trace (corresponding to the TraceFile DBParm parameter) are emphasized.

```
DBMS      "TRACE JDBC"
DbParm    "Driver='com.sybase.jdbc3.jdbc.SybDriver',
          URL='jdbc:sybase:Tds:199.93.178.151:
          5007/tsdata',TraceFile='c:\temp\jdbc.log'"
```

- 5 Click Connect in the Database Profiles dialog box to connect to the database

or

Right-click on the connected database and select Re-connect from the drop-down menu in the Database Profiles dialog box.

InfoMaker connects to the database, starts tracing the JDBC connection, and writes output to the log file you specified.

Stopping JDBC Driver Manager Trace

Once you start tracing a JDBC connection with JDBC Driver Manager Trace, InfoMaker continues sending trace output to the log file until you stop tracing.

Stopping JDBC Driver Manager Trace

❖ **To stop JDBC Driver Manager Trace:**

- 1 Open the Database Profile Setup - JDBC dialog box for the connection you are tracing.

For instructions, see “Starting JDBC Driver Manager Trace” on page 178.

- 2 On the Options tab, clear the Trace JDBC Calls check box.

If you supplied the path name of a log file in the Trace File box, you can leave it specified in case you want to restart tracing later.

- 3 Click OK in the Database Profile Setup - JDBC dialog box.

The Database Profiles dialog box displays, with the name of the edited profile highlighted.

- 4 Click Connect in the Database Profiles dialog box or right click on the connected database and select Re-connect from the drop-down menu in the Database Profiles dialog box.

InfoMaker connects to the database and stops tracing the connection.

Viewing the JDBC Driver Manager Trace log

You can display the contents of the JDBC Driver Manager Trace log file anytime during an InfoMaker session.

Location of JDBC.LOG

For information about where to find the default *JDBC.LOG* file, see “About JDBC Driver Manager Trace” on page 177.

❖ To view the contents of the log file:

- Open *JDBC.LOG* or the log file you specified in one of the following ways:
 - Use the File Editor in InfoMaker. (For instructions, see the *Users Guide*.)
 - Use any text editor outside InfoMaker.

Leaving the log file open

If you leave the log file open as you work in InfoMaker, JDBC Driver Manager Trace *does not update the log*.

Appendix

The Appendix describes how to modify the PBODB115 initialization file.

Adding Functions to the PBODB115 Initialization File

About this appendix

Usually, *you do not need to modify the PBODB115 initialization file*. In certain situations, however, you might need to add functions to the PBODB115 initialization file for connections to your back-end DBMS through the ODBC or OLE DB interface in InfoMaker.

This appendix describes how to add functions to the PBODB115 initialization file if necessary.

Contents

Topic	Page
About the PBODB115 initialization file	183
Adding functions to PBODB115.INI	184

About the PBODB115 initialization file

What is the PBODB115 initialization file?

When you access data through the ODBC interface, InfoMaker uses the PBODB115 initialization file (*PBODB115.INI*) to maintain access to extended functionality in the back-end DBMS for which ODBC does not provide an API call. Examples of extended functionality are SQL syntax or function calls specific to a particular DBMS.

Editing PBODB115.INI

In most cases, you do *not* need to modify *PBODB115.INI*. Changes to this file can adversely affect InfoMaker. Change *PBODB115.INI* only if you are asked to do so by a Technical Support representative.

However, you *can* edit *PBODB115.INI* if you need to add functions for your back-end DBMS.

If you modify *PBODB115.INI*, first make a copy of the existing file. Then keep a record of all changes you make. If you call Technical Support after modifying *PBODB115.INI*, tell the representative that you changed the file and describe the changes you made.

Adding functions to PBODB115.INI

PBODB115.INI lists the functions for certain DBMSs that have ODBC drivers. If you need to add a function to *PBODB115.INI* for use with your back-end DBMS, you can do either of the following:

- **Existing sections** Add the function to the Functions section for your back-end database if this section exists in *PBODB115.INI*.
- **New sections** Create new sections for your back-end DBMS in *PBODB115.INI* and add the function to the newly created Functions section.

Adding functions to an existing section in the file

If sections for your back-end DBMS *already exist* in *PBODB115.INI*, use the following procedure to add new functions.

❖ **To add functions to an existing section in PBODB115.INI:**

- 1 Open *PBODB115.INI* in one of the following ways:
 - Use the File Editor in InfoMaker. (For instructions, see the *Users Guide*.)
 - Use any text editor outside InfoMaker.
- 2 Locate the entry for your back-end DBMS in the DBMS Driver/DBMS Settings section of *PBODB115.INI*.

For example, here is the *PBODB115.INI* entry for SQL Anywhere:

```
;*****  
;DBMS Driver/DBMS Settings see comments at end  
;of file  
;*****  
...  
[SQL Anywhere]  
PBSyntax='WATCOM50_SYNTAX'  
PBDateTime='STANDARD_DATETIME'  
PBFunctions='ASA_FUNCTIONS'  
PBDefaultValues='autoincrement,current date,  
current time,current timestamp,timestamp,  
null,user'  
PBDefaultCreate='YES'  
PBDefaultAlter='YES'  
PBDefaultExpressions='YES'
```

```

DelimitIdentifier='YES'
PBDateInvalidInSearch='NO'
PBTimeInvalidInSearch='YES'
PBQualifierIsOwner='NO'
PBSpecialDataTypes='WATCOM_SPECIALDATATYPES'
IdentifierQuoteChar='"'
PBSystemOwner='sys, dbo'
PBUseProcOwner='YES'
SQLSrvrTSName='YES'
SQLSrvrTSQuote='YES'
SQLSrvrTSDelimit='YES'
ForeignKeyDeleteRule='Disallow if Dependent Rows
    Exist (RESTRICT),Delete any Dependent Rows
    (CASCADE),Set Dependent Columns to NULL
    (SET NULL) '
TableListType='GLOBAL TEMPORARY'

```

- 3 Find the name of the section in *PBODB115.INI* that contains function information for your back-end DBMS.

To find this section, look for a line similar to the following in the DBMS Driver/DBMS Settings entry:

```
PBFunctions='section_name'
```

For example, the following line in the DBMS Driver/DBMS Settings entry for SQL Anywhere indicates that the name of the Functions section is *ASA_FUNCTIONS*:

```
PBFunctions='ASA_FUNCTIONS'
```

- 4 Find the Functions section for your back-end DBMS in *PBODB115.INI*.

For example, here is the Functions section for SQL Anywhere:

```

;*****
;Functions
;*****
[ASA_FUNCTIONS]
AggrFuncs=avg(x),avg(distinct x),count(x),
count(distinct x),count(*),list(x),
list(distinct x),max(x),max(distinct x),
min(x),min(distinct x),sum(x),sum(distinct x)
Functions=abs(x),acos(x),asin(x),atan(x),
atan2(x,y),ceiling(x),cos(x),cot(x),degrees(x),
exp(x),floor(x),log(x),log10(x),
mod(dividend,divisor),pi(*),power(x,y),
radians(x),rand(),rand(x),
remainder(dividend,divisor),round(x,y),

```

```
sign(x), sin(x), sqrt(x), tan(x),
"truncate"(x,y), ascii(x), byte_length(x),
byte_substr(x,y,z), char(x), char_length(x),
charindex(x,y), difference(x,y) insertstr(x,y,z),
lcase(x), left(x,y), length(x), locate(x,y,z),
lower(x), ltrim(x), patindex('x',y), repeat(x,y),
replicate(x,y), right(x,y), rtrim(x),
similar(x,y), soundex(x), space(x), str(x,y,z),
string(x,...), stuff(w,x,y,z), substr(x,y,z),
trim(x), ucase(x), upper(x), date(x),
dateformat(x,y), datename(x,y), day(x),
dayname(x), days(x), dow(x), hour(x), hours(x),
minute(x), minutes(x), minutes(x,y), month(x),
monthname(x), months(x), months(x,y), now(*),
quarter(x), second(x), seconds(x), seconds(x,y),
today(*), weeks(x), weeks(x,y), year(x), years(x),
years(x,y), ymd(x,y,z), dateadd(x,y,z),
datediff(x,y,z), datename(x,y), datepart(x,y),
getdate(), cast(x as y), convert(x,y,z),
hextoint(x), inttohex(x),
connection_property(x,...), datalength(x),
db_id(x), db_name(x), db_property(x),
next_connection(x), next_database(x),
property(x), property_name(x),
property_number(x), property_description(x),
argn(x,y,...), coalesce(x,...),
estimate(x,y,z), estimate_source(x,y,z),
experience_estimate(x,y,z), ifnull(x,y,z),
index_estimate(x,y,z), isnull(x,...),
number(*), plan(x), traceback(*)
```

5 To add a new function, type a comma followed by the function name at the end of the appropriate function list, as follows:

- **Aggregate functions** Add aggregate functions to the end of the AggrFuncs list.
- **All other functions** Add all other functions to the end of the Functions list.

Case sensitivity

If the back-end DBMS you are using is case sensitive, be sure to use the required case when you add the function name.

The following example shows a new function for SQL Anywhere added at the end of the Functions list:

```

;*****
;Functions
;*****
[ASA_FUNCTIONS]
AggrFuncs=avg(x),avg(distinct x),count(x),
count(distinct x),count(*),list(x),
list(distinct x),max(x),max(distinct x),
min(x),min(distinct x),sum(x),sum(distinct x)
Functions=abs(x),acos(x),asin(x),atan(x),
atan2(x,y),ceiling(x),cos(x),cot(x),degrees(x),
exp(x),floor(x),log(x),log10(x),
mod(dividend,divisor),pi(*),power(x,y),
radians(x),rand(),rand(x),
...
number(*),plan(x),traceback(*),newfunction()

```

6 Save your changes to *PBODB115.INI*.

Adding functions to a new section in the file

If entries for your back-end DBMS *do not exist* in *PBODB115.INI*, use the following procedure to create the required sections and add the appropriate functions.

Before you start

For more about the settings to supply for your back-end DBMS in *PBODB115.INI*, read the comments at the end of the file.

❖ To add functions to a new section in *PBODB115.INI*:

- 1 Open *PBODB115.INI* in one of the following ways:
 - Use the File Editor in InfoMaker. (For instructions, see the *Users Guide*.)
 - Use any text editor outside InfoMaker.
- 2 Edit the DBMS Driver/DBMS Settings section of the *PBODB115* initialization file to add an entry for your back-end DBMS.

Finding the name

The name required to identify the entry for your back-end DBMS in the DBMS Driver/DBMS Settings section is in *PBODB115.INI*.

Make sure that you:

- Follow the instructions in the comments at the end of *PBODB115.INI*.
- Use the same syntax as existing entries in the DBMS Driver/DBMS Settings section of *PBODB115.INI*.
- Include a section name for PBFunctions.

For example, here is the relevant portion of an entry for a DB2/2 database:

```
;*****  
;DBMS Driver/DBMS Settings  
;*****  
[DB2/2]  
...  
PBFunctions='DB22_FUNCTIONS'  
...
```

- 3 Edit the Functions section of *PBODB115.INI* to add an entry for your back-end DBMS.

Make sure that you:

- Follow the instructions in the comments at the end of *PBODB115.INI*.
- Use the same syntax as existing entries in the Functions section of *PBODB115.INI*.
- Give the Functions section the name that you specified for PBFunctions in the DBMS Driver/DBMS Settings entry.

For example:

```
;*****  
;Functions  
;*****  
[DB22_FUNCTIONS]  
AggrFuncs=avg(),count(),list(),max(),min(),sum()  
Functions=curdate(),curtime(),hour(),...
```

- 4 Type a comma followed by the function name at the end of the appropriate function list, as follows:

- **Aggregate functions** Add aggregate functions to the end of the AggrFuncs list.

- **All other functions** Add all other functions to the end of the Functions list.

Case sensitivity

If the back-end DBMS you are using is case sensitive, be sure to use the required case when you add the function name.

The following example shows (in bold) a new DB2/2 function named `substr()` added at the end of the Functions list:

```

;*****
;Functions
;*****
[DB22_FUNCTIONS]
AggrFuncs=avg(),count(),list(),max(),min(),sum()
Functions=curdate(),curtime(),hour(), substr()

```

- 5 Save your changes to *PBODB115.INI*.

Index

A

- accessing databases
 - ODBC data sources 22
 - troubleshooting any connection 164
 - troubleshooting JDBC connections 177
 - troubleshooting ODBC connections 173
- API conformance levels for ODBC 19
- applications
 - in database interface connections 52
 - in ODBC connections 15
- ASE DBMS identifier 55
- AutoCommit database preference
 - setting in database profile 158
- AutoConnect setting in InfoMaker initialization file 139
- Automatically Connect to Database system option 138

B

- basic procedures
 - defining database interfaces 53
 - editing database profiles 143
 - importing and exporting database profiles 147
 - preparing ODBC data sources 21
 - selecting a database profile to connect 140
 - setting database parameters 155
 - setting database preferences 158
 - setting DBParm parameters 157
 - sharing database profiles 143
 - stopping Database Trace 169
 - stopping JDBC Driver Manager Trace 179
 - stopping ODBC Driver Manager Trace 175

C

- case sensitivity, in PBODB115 initialization file 186, 189
- client software
 - DirectConnect 129
 - Informix 75, 83
 - Microsoft SQL Server 90
 - Oracle 109
 - Sybase Adaptive Server Enterprise 59
- columns
 - identity, Sybase Adaptive Server Enterprise 56
 - in extended attribute system tables 151
 - special timestamp, in Sybase SQL Anywhere 31
 - SQL naming conventions 21
- conformance levels for ODBC drivers 19
- Connect DB at Startup database preference 160
- connect descriptors
 - ODBC 24
 - Oracle 113
- connecting to databases
 - about 10, 137, 141
 - and extended attribute system tables creation 149
 - at startup or from a painter 139
 - Automatically Connect to Database system option 138
 - by selecting a database profile 140
 - in InfoMaker with other Sybase products 5
 - troubleshooting any connection 164
 - troubleshooting JDBC connections 177
 - troubleshooting ODBC connections 173
 - using database profiles 139
- ConnectionString DBParm in ODBC connections 24
- conventions x
- CT-Library client software
 - for DirectConnect 129
 - for Sybase Adaptive Server Enterprise 55, 59
 - for Sybase Systems 45

- D**
- data providers
 - and OLE DB interface 42
 - obtaining 44
 - database interfaces
 - about 51
 - connecting to databases 140
 - connection components 52
 - creating database profiles 22
 - defining 53
 - DirectConnect 123
 - editing database profiles 143
 - importing and exporting database profiles 147
 - Informix 75
 - JDBC 34
 - Microsoft SQL Server 87
 - Oracle 105
 - preparing databases 53
 - sharing database profiles 143
 - Sybase Adaptive Server Enterprise 55
 - troubleshooting 164
 - Database painter, changing SQL terminator character 115
 - database parameters
 - character limit for strings in database profiles 157
 - ConnectionString 24
 - for Sybase Open Client directory services 67
 - how to set 155
 - in ODBC connections 24
 - database preferences
 - AutoCommit 158
 - Connect DB at Startup 160
 - how to set 155
 - Keep Connection Open 160
 - Lock 158
 - Read Only 153, 160
 - setting in Database Preferences dialog box 160
 - setting in database profiles 8, 158
 - Shared Database Profiles 144, 160
 - SQL Terminator Character 160
 - Use Extended Attributes 153, 160
 - Database Preferences dialog box
 - about 160
 - General page, values for 160
 - SQL Terminator Character box 115
 - Database Preferences property sheet
 - General property page, values for 144
 - Database Profile button 140
 - Database Profile Setup dialog box
 - Auto Commit Mode check box 158
 - character limit for DBParm strings 157
 - editing profiles 143
 - Generate Trace check box 169
 - Isolation Level box 158
 - JDBC Driver Manager Trace, stopping 179
 - ODBC Driver Manager Trace, stopping 175
 - supplying sufficient information to connect 9
 - Trace File box 178
 - Trace JDBC Calls check box 178
 - Trace ODBC API Calls check box 174
 - database profiles
 - about 6, 139
 - character limit for DBParm strings 157
 - connect string for ODBC data sources 24
 - DBMS value for ODBC data sources 24
 - editing 143
 - importing and exporting 147
 - JDBC Driver Manager Trace, starting 178
 - JDBC Driver Manager Trace, stopping 179
 - Microsoft SQL Native Client database interface 91
 - ODBC Driver Manager Trace, starting 174
 - ODBC Driver Manager Trace, stopping 175
 - Oracle database interfaces 113
 - selecting in Database Profiles dialog box 140
 - server name for Sybase Open Client directory services 66
 - setting Isolation Level and AutoCommit Mode 158
 - shared 143, 145, 147
 - suppressing password display 142
 - Sybase Adaptive Server Enterprise database interface 61
 - Sybase DirectConnect interface 131
 - Database Profiles dialog box
 - about 140
 - displaying shared profiles 145
 - Database section in initialization files 141
 - Database Trace
 - about 164
 - annotating the log 170
 - deleting or clearing the log 170
 - log file contents 165
 - log file format 167

- sample output 171
 - viewing the log 169
 - databases
 - accessing 22
 - connecting at startup in InfoMaker 138
 - connecting at startup or from a painter 139
 - connecting with database profiles 139, 140
 - in database interface connections 52
 - logging on for the first time 149
 - datatypes
 - Adaptive Server 56
 - DirectConnect 126
 - Informix 76
 - Microsoft SQL Server 88
 - Oracle 106
 - special timestamp, Transact-SQL 31
 - SQL Server 88
 - Sybase Adaptive Server Enterprise 56
 - DateTime datatype, Informix 76
 - DB2/CS, IBM, DB2SYSPB.SQL script, using 132
 - DB2/MVS, IBM
 - accessing through DirectConnect 123
 - accessing through Open ServerConnect 123
 - DB2SYSPB.SQL script, using 132
 - DB2SYSPB.SQL script 133
 - DBMS
 - back end, adding ODBC functions for 184
 - entries in PBODB115 initialization file 184, 187
 - system tables, displaying 149
 - value in database profiles 24
 - DBMS identifier
 - ASE 55
 - DIR 123
 - I10 75
 - IN9 75
 - O10 105
 - O90 105
 - ORA 105
 - SNC 87
 - SYC 55
 - DBParm parameters
 - for Sybase Open Client security services 63
 - PBCatalogOwner 134
 - DBTRACE.LOG file
 - about 164
 - annotating 170
 - contents 165
 - deleting or clearing 170
 - format 167
 - leaving open 169
 - sample output 171
 - viewing 169
 - defining database interfaces
 - about 53
 - DirectConnect 131
 - editing database profiles 143
 - importing and exporting database profiles 147
 - Microsoft SQL Server 91
 - Oracle 113
 - sharing database profiles 143
 - Sybase Adaptive Server Enterprise 61
 - defining ODBC data sources
 - about 22
 - creating configurations and database profiles 22
 - editing database profiles 143
 - multiple data sources 25
 - sharing database profiles 143
 - Sybase SQL Anywhere 29
 - DIR DBMS identifier 123
 - DirectConnect interface. *See* Sybase DirectConnect interface
 - directory services, Sybase Open Client. *See* Sybase Open Client directory services
 - display formats, in extended attribute system tables 151
 - DIT base for Sybase Open Client directory services 66
 - DLL files
 - in database interface connections 52
 - in JDBC connections 35
 - in ODBC connections 15
 - ODBC.DLL 15
 - ODBC32.DLL 15
 - PBODB115.DLL 15
 - DSN (data source name) value, in ODBC connect strings 24
- E**
- EAS Demo DB 15
 - edit styles, in extended attribute system tables 151

Index

editing
 database profiles 143
 PBODB115 initialization file 183
 shared database profiles 146
exporting a database profile 148
extended attribute system tables
 about 132, 148
 contents 151
 controlling creation with Use Extended Attributes
 database preference 153
 controlling permissions 154
 controlling updates with Read Only database
 preference 153
 creating in DB2 databases 132
 displaying 149
 ensuring proper creation 149
 PBOwner in DB2SYSPB.SQL script 134
Extended SQL conformance level for ODBC 20

F

functions, ODBC
 adding to existing section in PBODB115 initialization
 file 184
 adding to new section in PBODB115 initialization
 file 187

G

General page in Database Preferences dialog box 160
General property page in Database Preferences property
sheet 144
Generate Trace check box in Database Profile Setup dialog
box 169
granting permissions on extended attribute system
tables 154

H

help 20
 data source 13
 Database Trace, using 164
 for ODBC drivers 20, 25

Java Web site 33
JDBC Driver Manager Trace, using 177
JDBC Web site 33
Microsoft Universal Data Access 41
ODBC Driver Manager Trace, using 173
 online Help, using 13, 20
Sybase Web site 41
heterogeneous cross-database joins 67

I

I10 DBMS identifier 75
IBM database interface, DB2SYSPB.SQL script,
 using 132
identity columns and datatype, Sybase Adaptive Server
 Enterprise 56
importing a database profile 148
IN9 DBMS identifier 75
InfoMaker
 Automatically Connect to Database system
 option 138
 connectivity with other Sybase products 5
 Preview tab unavailable 8
InfoMaker initialization file
 about 143
 AutoConnect setting 139
 locating when sharing database profiles 143
 saving shared database profiles locally 146
 setting Shared Database Profiles database
 preference 144
 suppressing password display 142
Informix client software 75, 83
Informix database interface
 client software required 83
 connection components 82
 databases supported 75
 datatypes supported 76
 features supported by I10 77
 installing 84
 preparing the database 82
 verifying the connection 84
initialization files
 AutoConnect setting in InfoMaker 139
 DBMS_PROFILES section 147
 in ODBC connections 22

- locating when sharing database profiles 143
- ODBC 23
- ODBCINST 23
- PBODB115 adding functions to 183
- storing connection parameters 10, 141
- suppressing password display 142
- installing
 - Java virtual machines 35
- interval datatype, Informix 77
- isolation levels and lock values, setting in database profiles 158
- ISQL, using to install stored procedures 71

J

- Java virtual machines, installing 35
- Java Web site 33
- JDBC connections, troubleshooting 177
- JDBC database interface, troubleshooting 177
- JDBC Driver Manager Trace
 - about 177
 - availability on different platforms 178
 - performance considerations 177
 - specifying a nondefault log file 178
 - starting 178
 - stopping 179
 - viewing the log 180
- JDBC drivers, troubleshooting 177
- JDBC interface
 - about 33
 - components 34
 - data types supported 37
 - database server configuration 38
 - DLL files required 35
 - drivers 36
 - Java classes package 35
 - Java virtual machines 35
 - PBJDB115.DLL 37
 - registry entries 36
 - specifying connection parameters 39
- JDBC Web site 33
- JDBC.LOG file
 - about 177
 - leaving open 180
 - performance considerations 177

- using nondefault log file instead 178
- viewing 180

K

- Keep Connection Open database preference 160

L

- large object, as output parameter in Oracle stored procedure 118
- Level 1 API conformance level for ODBC 19
- Lock database preference
 - setting in database profiles 158
- lock values and isolation levels, setting in database profiles 158
- LOG files
 - JDBC.LOG 177, 180
 - PBTRACE.LOG 164, 169
 - specifying nondefault for JDBC Driver Manager Trace 178
 - SQL.LOG 173, 176
- logging in to databases for the first time 149

M

- maintaining shared database profiles 147
- Microsoft Data Link, using with OLE DB interface 47
- Microsoft SQL Native Client database interface
 - client software required 90
 - connection components 89
 - datatypes supported 88
 - defining 91
 - installing 91
 - preparing the database 89
 - verifying the connection 91
 - versions supported 87
- Microsoft Universal Data Access Web site 41
- Minimum SQL conformance level for ODBC 19
- multiple ODBC data sources, defining 25
- multiple-tier ODBC drivers 18

N

- naming conventions, tables and columns 21
- NewLogic, database profile setting 10

O

- O10 DBMS identifier 105
- O10 Oracle 10g Driver 105
- O90 DBMS identifier 105
- O90 Oracle 9i Driver 105
- ODBC 20
- ODBC (Open Database Connectivity)
 - about 14
 - components 15
 - defining data sources 22
 - defining multiple data sources 25
 - driver conformance levels 19
 - ODBC initialization file 23
 - ODBCINST initialization file 23
 - preparing data sources 21
 - translators, selecting for drivers 26
- ODBC connect strings 24
- ODBC data sources
 - accessing 22
 - creating configurations and database profiles 22
 - defining 22
 - defining multiple 25
 - editing database profiles 143
 - in ODBC connections 15
 - in ODBC initialization file 23
 - in ODBCINST initialization file 23
 - PBODB115 initialization file 183
 - preparing 21
 - sharing database profiles 143
 - Sybase SQL Anywhere 27
 - translators, selecting for drivers 26
 - troubleshooting 164, 173
- ODBC Driver Manager 15
- ODBC Driver Manager Trace
 - about 173
 - performance considerations 173
 - sample output 176
 - starting 174
 - viewing the log 176
- ODBC drivers
 - about 14
 - API conformance levels 19
 - conformance levels, recommendations for 19
 - displaying Help 13, 20, 25
 - in ODBC connections 15
 - multiple-tier 18
 - PBODB115 initialization file 183
 - SQL conformance levels 19
 - Sybase SQL Anywhere 27
 - translators, selecting 26
 - troubleshooting 164, 173
 - using 15
- ODBC functions
 - adding to existing section in PBODB115 initialization file 184
 - adding to new section in PBODB115 initialization file 187
- ODBC initialization file
 - about 23
 - and PBODB115 initialization file 187
- ODBC interface
 - about 14
 - connecting to data sources 140
 - DLL files required 15
 - initialization files required 22
 - ODBC initialization file 23
 - PBODB115 initialization file 183
 - troubleshooting 164, 173
 - using 15
- ODBCINST initialization file 23
- OLE DB interface 42
 - components 44
 - data provider 42
 - getting help 41
 - installing data providers 46
 - object interfaces supported 42
 - obtaining data providers, from other vendors 44
 - PBOLE115.DLL 45
 - specifying connection parameters 47
 - using Data Link 47
- Open Client software, Sybase 45, 59, 129
- ORA DBMS identifier 105
- ORA Oracle 11g Driver 105
- Oracle database interfaces
 - client software required 109

- connect strings or descriptors, specifying 113
- connection components 108
- datatypes supported 106
- defining 113
- preparing the database 109
- using Oracle stored procedures 114
- verifying the connection 110
- versions supported 105
- Oracle SQL*Net client software 109
- Oracle stored procedure, using LOB output parameter 118

P

- passwords, suppressing display 142
- PBCatalogOwner DBParm parameter, and DB2SYSPB.SQL script 134
- pbcatcol table 151
- pbcatedt table 151
- pbcatfmt table 151
- pbcattbl table 151
- pbcatvld table 151
- PBIN9115.DLL file 82
- PBJDB115.DLL 37
- PBO10115.DLL file 105
- PBO90115.DLL file 105
- PBODB115 initialization file
 - about 183
 - adding functions to existing section 184
 - adding functions to new section 187
 - case sensitivity 186, 189
 - finding DBMS section names in ODBC initialization file 187
 - special timestamp column support 32
- PBODB115.DLL file 15
- PBOLE115.DLL file 45
- PBORA115.DLL file 105
- PBSNC115.DLL file 89
- PBSYC.SQL script
 - about 69
 - compared to PBSYC2.SQL script 71
 - finding 69
 - running with ISQL 71
 - running with WISQL 72
 - when to run 69

- PBSYC2.SQL script
 - about 70
 - compared to PBSYC.SQL script 71
 - finding 69
 - running with ISQL 71
 - running with WISQL 72
 - when to run 70
- permissions, granting on system tables 154
- preparing databases for use with database interfaces
 - about 53
 - DirectConnect 128
 - Informix 82
 - Microsoft SQL Server 89
 - Oracle 109
 - Sybase Adaptive Server Enterprise 45, 59
- preparing ODBC data sources
 - about 21
 - Sybase SQL Anywhere 28
- Preview tab, unavailable in InfoMaker 8
- PRINT statements in SQL Server stored procedures 67
- procedures, basic
 - setting DBParm parameters 157
- Prompt for Database Information check box 142

R

- Read Only database preference 153, 160
- registry, Windows
 - connection parameters in 10, 141
 - ODBC initialization file 23
 - ODBCINST initialization file 23
- result sets, using Oracle stored procedures 115

S

- security services, Sybase Open Client. *See* Sybase Open Client security services
- Select Tables dialog box, Show system tables check box 149
- Select Translator dialog box 26
- semicolons, as default SQL terminator character 115
- SERVER directory files
 - for creating repository in DB2 databases 133

Index

- for installing stored procedures in Adaptive Server Enterprise databases 69
- server name, specifying for Sybase Open Client directory services 66
- shared database profiles
 - maintaining 147
 - saving in local initialization file 146
 - setting up 144
- Show system tables check box 149
- SNC DBMS identifier 87
- sp_pb115table stored procedure
 - in PBSYC.SQL script 69
 - in PBSYC2.SQL script 71
- SQL Anywhere ODBC Configuration dialog box 29
- SQL conformance levels for ODBC 19
- SQL files
 - DB2SYSPB.SQL 133
 - PBSYC.SQL 69
 - PBSYC2.SQL 70
- SQL naming conventions for tables and columns 21
- SQL terminator character, changing in Database painter 115, 160
- SQL*Net client software, Oracle 109
- SQL.LOG file
 - about 173
 - leaving open 176
 - performance considerations 173
 - sample output 176
 - viewing 176
- stored procedures
 - about 68
 - created by PBSYC.SQL script 69
 - created by PBSYC2.SQL script 71
 - installing in Adaptive Server Enterprise databases 68
 - ISQL, using to install 71
 - not required for Microsoft SQL Server database interface 68
 - running scripts 71
 - where to find scripts 69
 - WISQL, using to install 72
- stored procedures, Oracle
 - about 114
 - changing SQL terminator character 115, 160
 - creating DataWindows and reports 117
 - how to use 114
 - with result sets, examples 115
 - with result sets, using 115
- stored procedures, SQL Server, using PRINT statements 67
- Sybase Adaptive Server Anywhere. *See* Sybase SQL Anywhere
- Sybase Adaptive Server Enterprise database interface
 - client software required 45, 59
 - creating a DW based on a heterogeneous cross-database join 67
 - datatypes supported 56
 - defining 61
 - directory services, using 64
 - identity columns 56
 - installing 60
 - installing stored procedures 68
 - platforms supported 55
 - preparing the database 45, 59
 - security services, using 62
 - verifying the connection 61
 - versions supported 55
- Sybase DirectConnect interface
 - client software required 129
 - data types supported 126
 - DB2SYSPB.SQL script, using 132
 - defining 131
 - platforms supported 125
 - preparing the database 128
 - using DirectConnect middleware 124
 - using Open ServerConnect middleware 124
 - verifying the connection 130
 - versions supported 125
- Sybase Open Client directory services
 - about 64
 - DBParm parameters 67
 - requirements for using 65
 - specifying the server name 66
- Sybase Open Client security services
 - about 62
 - DBParm parameters, login authentication 63
 - DBParm parameters, per-packet security 64
 - requirements for using 62
- Sybase Open Client software 45
 - about 59, 129
- Sybase SQL Anywhere
 - accessing remote databases 27

- adding functions to PBODB115 initialization file 184
- connection components 27
- creating configurations and database profiles 22
- defining the data source 29
- LOG files 29
- network server, not included 27
- platforms supported 27
- preparing to use 28
- special timestamp columns 31
- startup options, specifying 30
- using 15
- versions supported 27
- Sybase, getting help from 20
- sybtempprocs database, Sybase Adaptive Server Enterprise 72, 73
- SYC DBMS identifier 55
- SYSIBM, prohibited as DB2 table owner 134
- System Options dialog box 138
- system tables, displaying 149

T

- tables
 - extended attribute, creating in DB2 databases 132
 - in extended attributes 151
 - PBOwner in DB2SYSPB.SQL script 134
 - SQL naming conventions 21
 - system, displaying 149
- technical documents, Sybase, getting help from 13, 54
- time datatype, Informix 77
- timestamp, Transact-SQL special 31
- Trace File box in Database Profile Setup dialog box 178
- Trace JDBC Calls check box in Database Profile Setup dialog box 178
- Trace ODBC API Calls check box in Database Profile Setup dialog box 174
- tracing database connections
 - about 163
 - Database Trace 164
 - JDBC Driver Manager Trace 177
 - ODBC Driver Manager Trace 173

- sample output, Database Trace 171
- sample output, ODBC Driver Manager Trace 176
- Transact-SQL special timestamp in Sybase SQL Anywhere 31
- translators, ODBC 26
- troubleshooting database connections
 - about 163
 - Database Trace 164
 - JDBC Driver Manager Trace 177
 - ODBC Driver Manager Trace 173
- typographical conventions x

U

- Unicode
 - Adaptive Server 57
 - database password encryption 10
 - DirectConnect 123
 - ODBC 14, 36
 - OLE DB 43
 - Oracle9i, Oracle 10g 106
 - support 14, 36
- Use Extended Attributes database preference 153, 160

V

- validation rules, in extended attribute system tables 151

W

- WISQL, for installing stored procedures 72

